



GX-1B

Reference Manual

Before using this unit, carefully read the information in "USING THE UNIT SAFELY" and "IMPORTANT NOTES" (the leaflet "Read Me First"). After reading, keep the document(s) where it will be available for immediate reference.

Contents

Getting ready	3	[CTL1] (C1) switch color.....	53
Connecting the equipment	3	Main specifications	54
Supplying power to this unit.....	4		
Setting the type of amp to connect (OUTPUT SELECT)	5		
Tuning your bass guitar (TUNER).....	7		
Playing	9		
Selecting a memory.....	9		
About the play screen	10		
Editing: Effects	13		
Basic procedure for effect editing	13		
Editing the effects from the play screen.....	15		
About HEXARAY	16		
Recalling recommended settings for each effect (GEAR SUITE).....	17		
Editing the connection order for effects	18		
Switching memories without interrupting the sound	19		
Making the effect sound (reverberations) carry over when you switch memories (carryover).....	20		
Saving memories (WRITE)	22		
Saving as a GEAR SUITE	23		
Swapping Memories (MEMORY EXCHANGE)	25		
Changing the order of memories (MEMORY ORDER)	26		
Initializing memories (MEMORY INITIALIZE)	28		
Editing: MENU	30		
Basic menu operations	30		
Assigning the desired parameters to knobs [1]–[3] (KNOB SETTING)	30		
Setting the colors for the display and footswitches	31		
Restoring the factory settings (factory reset).....	33		
Connecting to a computer	35		
Connecting the mobile device	36		
Using this unit to hear audio played from a mobile device.....	36		
Mixing the sound of the song playing back on your mobile device with the sound of your bass playing	37		
Wireless connection with a mobile device	39		
Listening to sound from a wirelessly connected mobile device (Bluetooth® audio).....	39		
Controlling the unit from a mobile device app	41		
Footswitch and expression pedal settings	43		
Setting example 1: assigning an ON/OFF toggle for AMP SOLO to the [CTL1] (C1) switch	43		
Setting example 2: assigning the PEDAL FX ON/OFF switch to the EXP1 switch, and the PEDAL FX control to EXP1	45		
Adjusting the expression pedal (pedal calibration).....	47		
Connecting external pedals.....	50		
Looper	51		
Loop playback level setting.....	51		

Getting ready

This chapter explains how to get ready to play with the GX-1B, including connecting the devices, how to make the basic settings suitable for your amp and so on.

Connecting the equipment

- * To prevent malfunction and equipment failure, always turn down the volume, and turn off all the units before making any connections.
- * Before turning the unit on/off, always be sure to turn the volume down. Even with the volume turned down, you might hear some sound when switching the instrument on/off. This is normal and does not indicate a malfunction.

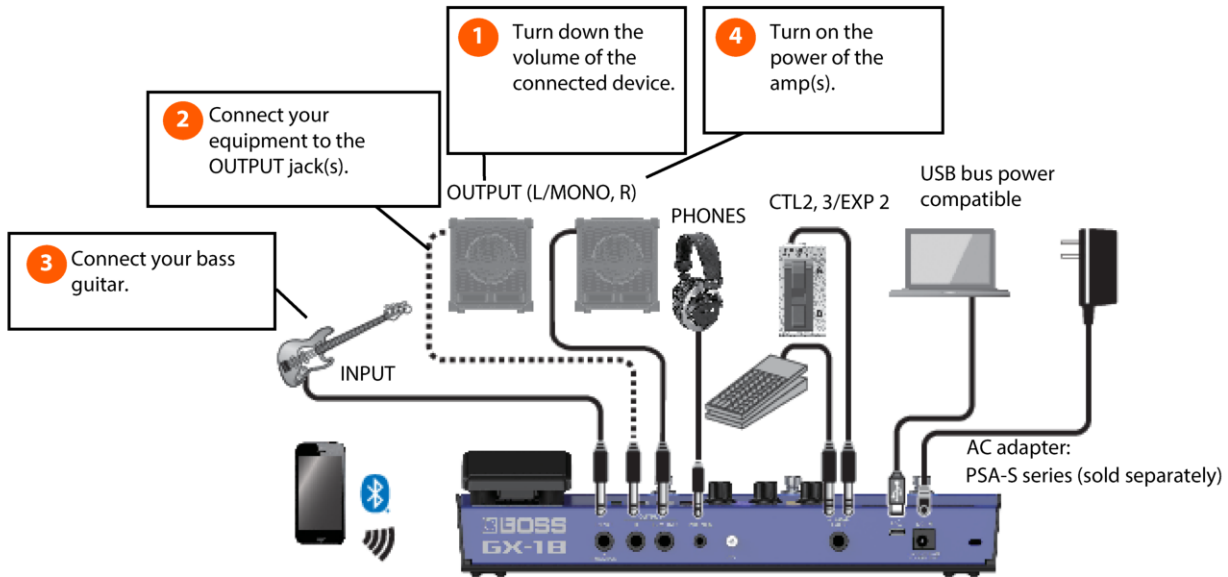

Name of jack, port or connector	Explanation
INPUT	Connect your bass guitar here. The INPUT jack also serves as the power switch. The power turns on whenever a plug is inserted into the INPUT jack, and turns off when the plug is disconnected.
OUTPUT L/MONO, R	Connect these to your bass amp, mixer or other external audio equipment. If using a mono connection, connect only to the L/MONO jack.
PHONES	Connect your headphones here.
Ground terminal 	Connect this to an external earth or ground. This should be connected when necessary.
CTL 2,3/EXP 2	You can control various parameters by connecting an expression pedal (Roland EV-5, BOSS EV-30: sold separately) or a footswitch (FS-5U, FS-6, FS-7: sold separately). * Use only the specified expression pedal. Connecting expression pedals made by third-party manufacturers may cause this unit to malfunction. * For more about footswitch settings, refer to “ Connecting external pedals (p. 50) ”.
↔ (USB Type-C[®])	Use a commercially available USB cable to connect to a computer, for exchanging audio/MIDI data between the GX-1B and the computer. You can use the GX-1B dedicated editor for editing and otherwise managing sounds. * Do not use a USB cable that is designed only for charging. Charge-only cables cannot transmit data. * This unit supports USB bus power. * If USB bus power is being supplied, the unit uses USB bus power even if batteries are installed. * A commercially available USB AC adaptor (5 V/500 mA or greater) is required to power this unit via the USB port. Some USB AC adaptors may not work with this instrument, depending on the manufacturer and type.

Getting ready

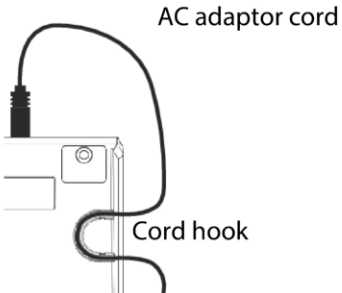
Name of jack, port or connector	Explanation
DC IN	<p>Connect an AC adaptor (BOSS PSA-S series, sold separately) here.</p> <ul style="list-style-type: none">* Use only the specified AC adaptor, and connect it to an AC outlet of the correct voltage.* Use the cord hook to secure the cord of the AC adaptor as shown in the illustration.* If the batteries are installed and the AC adaptor is connected, the AC adaptor supplies the power.  <p>AC adaptor cord</p> <p>Cord hook</p>

Supplying power to this unit

Installing the batteries

Install four alkaline batteries (AA, LR6) in the battery compartment located on the bottom of the unit.

- * When turning the unit over, be careful so as to protect the buttons and knobs from damage. Also, handle the unit carefully; do not drop it.
- * If you handle the battery improperly, you risk explosion and fluid leakage. Make sure that you carefully observe all of the items related to batteries that are listed in the "USING THE UNIT SAFELY" and "IMPORTANT NOTES" ("Read This First") leaflets for proper use.
- * We recommend that you keep batteries installed in the unit even though you'll be powering it with the AC adaptor. That way, you'll be able to continue a performance even if the cord of the AC adaptor gets accidentally disconnected from the unit.
- * Batteries should always be installed or replaced before connecting any other devices. This way, you can prevent malfunction and damage.
- * When the unit is operating on battery power and the batteries are almost depleted, "BATTERY LOW!" is displayed. Replace the batteries with new ones.

Supplying power via the USB port (using USB bus power)

- 1** Connect the commercially available USB Type-C[®] cable to a 5V USB AC adaptor or to the USB port on your computer.
- 2** Connect your bass to the INPUT jack on this unit, and turn on the power.

Setting the type of amp to connect (OUTPUT SELECT)

- 1 Press the [MENU] button.

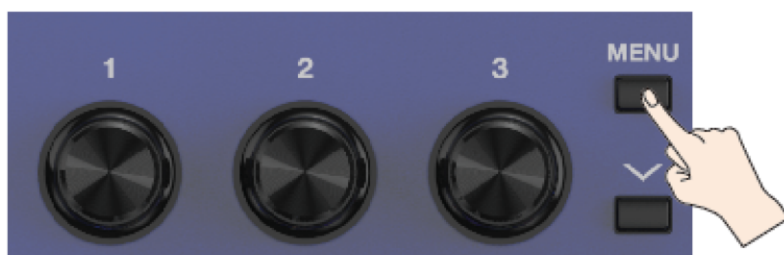

- 2 Press the [V][^] buttons to move the cursor to the "OUTPUT SELECT" row.

- 3 Press the [1] knob to select "OUTPUT SELECT".

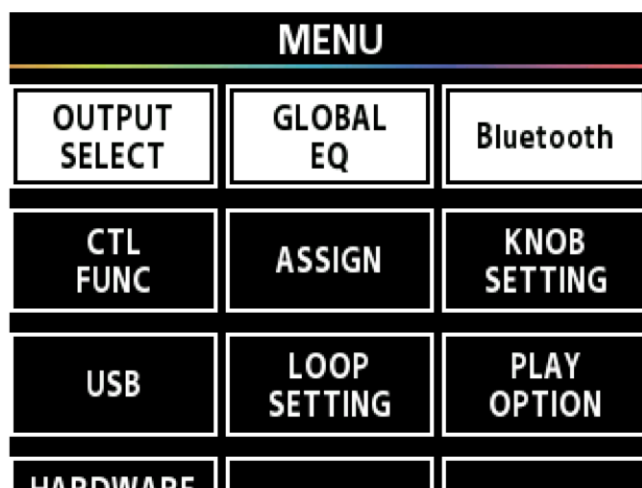

- 4 Turn knob [1] to select the type of amp.

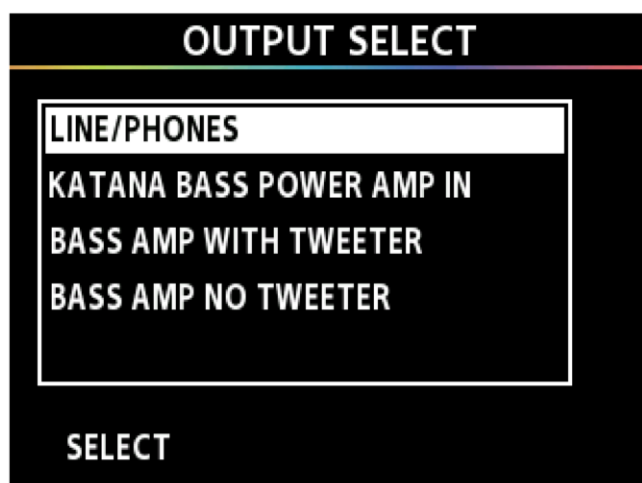

Value	Explanation
LINE/PHONES	Choose this setting if you're using headphones, or if the GX-1B is connected to a keyboard amp, mixer, or digital recorder.
KATANA BASS POWER AMP IN	Use this setting when connecting to the POWER AMP IN jack of a BOSS KATANA-210 BASS or a KATANA-110 BASS amp.
BASS AMP WITH TWEETER	Use this setting when connecting to a tweeter-equipped bass amp.

Getting ready

Value	Explanation
BASS AMP NO TWEETER	Use this setting when connecting to a bass amp that has no tweeter.

Tuning your bass guitar (TUNER)

- 1 Press the [▼] and [▲] switches at the same time.

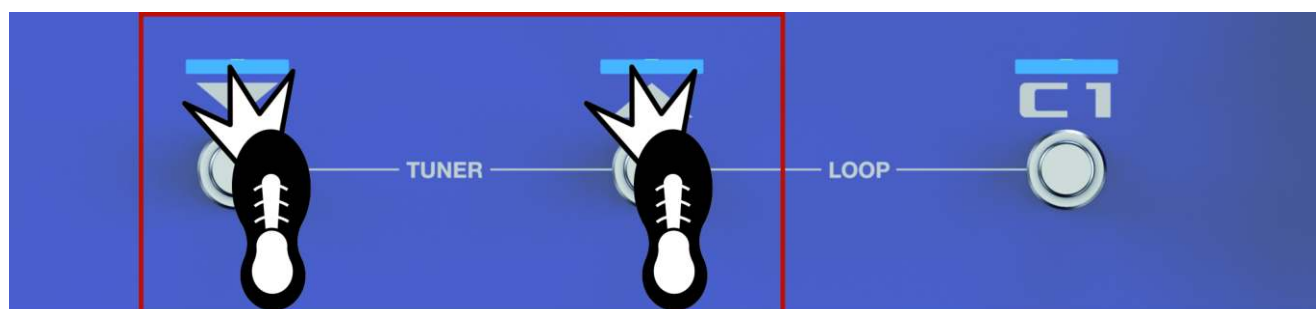

MEMO

- You can also start the tuner from the play screen by pressing the [V] button several times.
→“About the play screen (p. 10)”
- With the factory settings, you can move the expression pedal to minimum setting to start the tuner. See “Footswitch and expression pedal settings (p. 43)” for how to assign a different function.

- 2 Play an open string, and tune the string so that only the indicator in the center of the screen lights up.

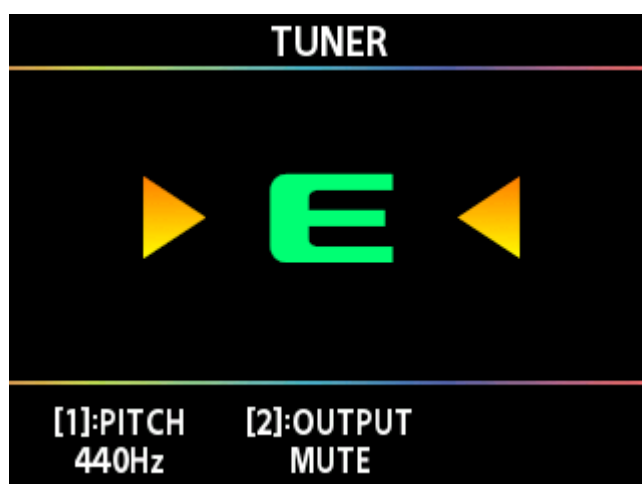

MEMO

You can also tune while checking the effect button indicators.

When the pitch is
accurate (lights up green)



- 3 To finish tuning, press the [▼][▲] switches simultaneously again.

MEMO

You can also finish tuning by pressing either the [▼], [▲] or [C1] switches, or by pressing the [EXIT] button.

Changing the reference pitch

When you turn the [1] knob while on the tuner screen, you can change the reference pitch of the tuner.

Getting ready

Parameter	Value
PITCH	435–445 Hz (default: 440 Hz)

Output settings

When you turn the [2] knob while on the tuner screen, you can change the settings for the output while using the tuner.

Parameter	Value	Explanation
TUNER OUTPUT	MUTE	Sound will not be output while tuning.
	BYPASS	While tuning, the sound of the bass guitar being input to the GX-1B will be output without change. All effects will be off.
	THRU	Lets you tune while outputting the current effect sound.

Playing

Now that you've finished getting ready, let's start playing with the GX-1B.

Selecting a memory

The GX-1B features many different effects.

A combination of effects and their settings is called a "memory".

There are two types of memories on the GX-1B: the 99 user memories (U01–U99), which can be overwritten; and the 99 preset memories (P01–P99), which can't be overwritten.

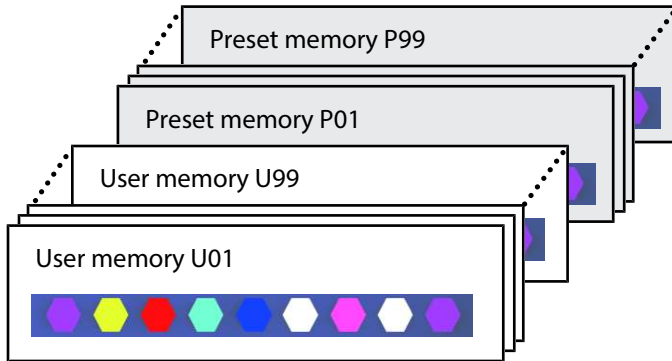

1 Open the "play screen (p. 10)".

You cannot switch memories while any screen other than the play screen is displayed. If another screen is shown, press the [EXIT] button to return to the play screen.

2 Press the [▼] [▲] switches to switch memories.

Press the [▼] switch to recall the previous memory, and press the [▲] switch to recall the next memory.

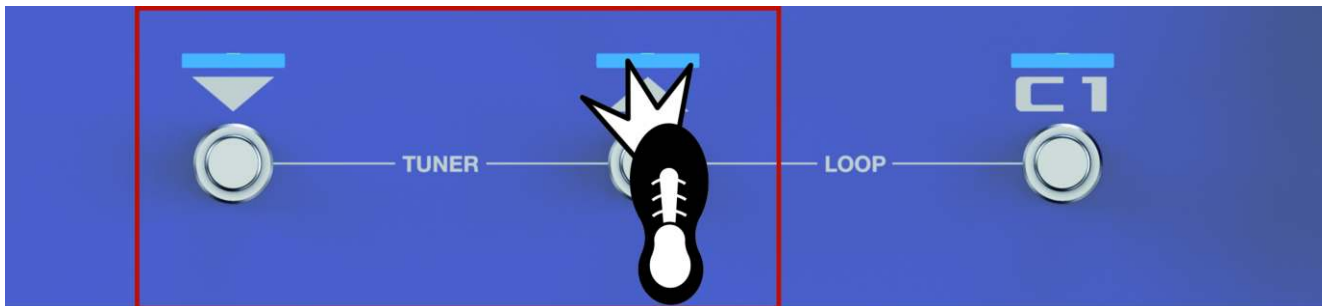

When a memory is selected, the indicators of the effect buttons that are activated in the memory light up.

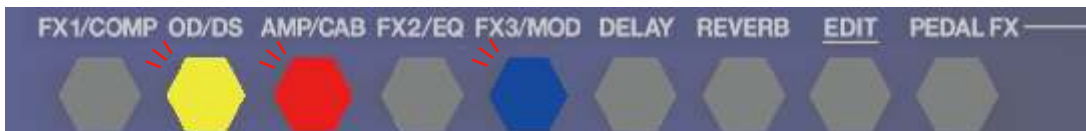

MEMO

You can also change memories by turning [1] knob below the display.



About the play screen

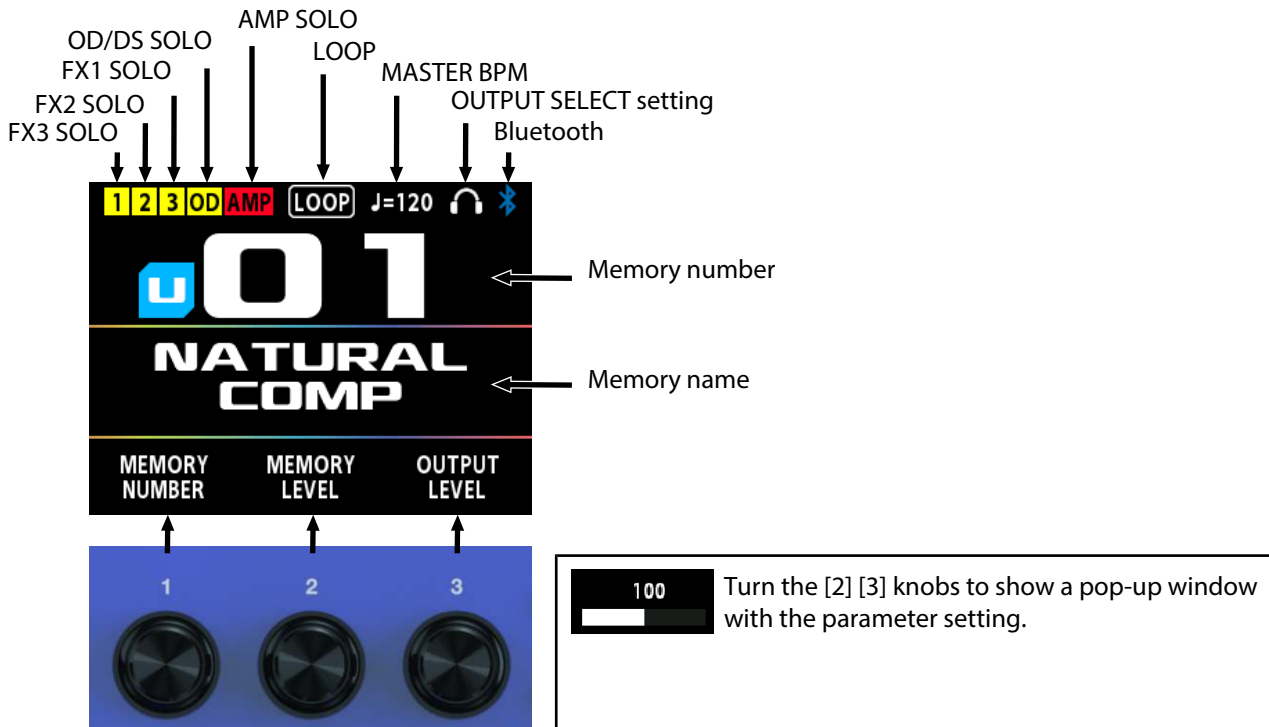

The screen that appears after you turn on the power is called the “Play screen”.

Memory name display mode



Use the knobs to change the functions assigned to KNOB SETTING.

Icon	Explanation
	Shows the master BPM.
	This is shown if OUTPUT is set to something other than “LINE/PHONES”.
	This is shown if OUTPUT is set to “LINE/PHONES”.
	Shows that the loop is on (no recorded data).
	Shows that the loop is in REC mode.
	Shows that the loop is in PLAY mode.
	Shows that the loop is in DUB mode.
	Shows that the loop is STOP mode (recorded data exists).
	This is shown when the AMP SOLO is on.
	This is shown when OD/DS SOLO is on.
	This is shown when the FX 1 SOLO is on.

Icon	Explanation
	This is shown when the FX2 SOLO is on.
	This is shown when the FX3 SOLO is on.

MEMO

Press the [V] [^] buttons to switch between the different types of views on the play screen.

Memory number display mode

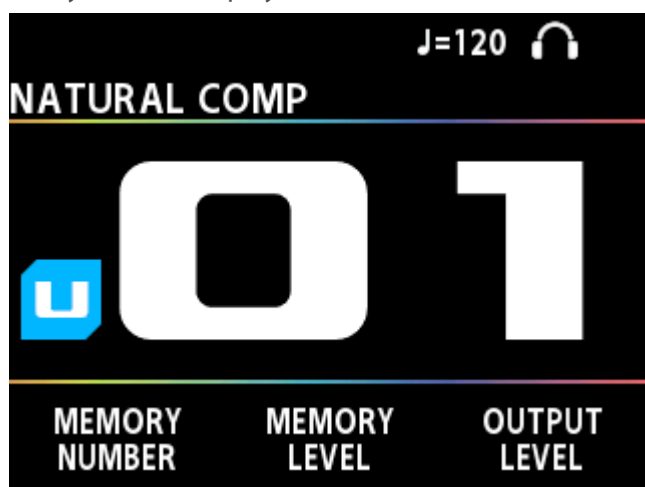

Control display mode

This mode shows the functions for [▼], [▲] and the CTL1 (C1) switches.

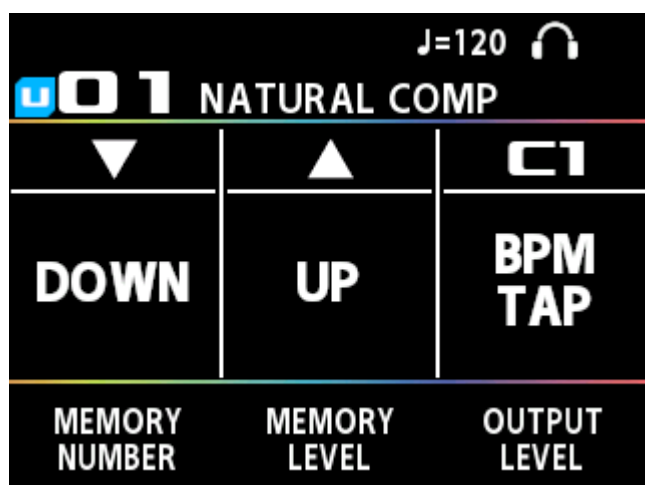

Playing

OUT settings and Bluetooth settings view type

This mode shows the output select, global EQ and Bluetooth settings.

You can jump to each settings screen by pressing the [1]–[3] knobs.

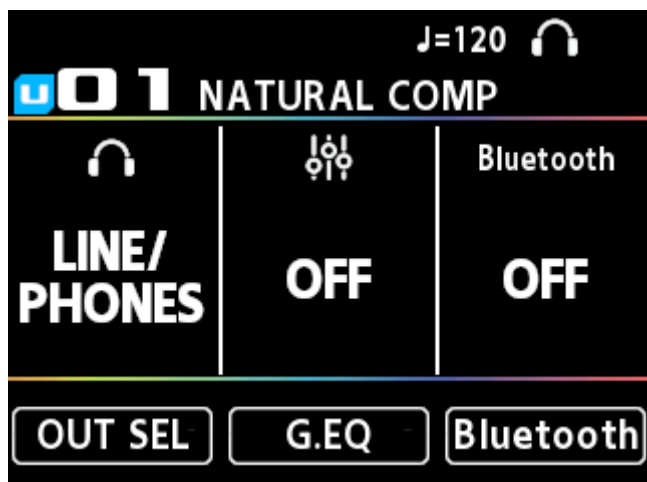

Editing: Effects

Basic procedure for effect editing

You can edit the effects by selecting the effect that you want to edit in the effect chain screen.

You can also edit effects and parameter settings that are not in the buttons on the panel.

1 Press the [EDIT] button.



The effect chain screen is shown.

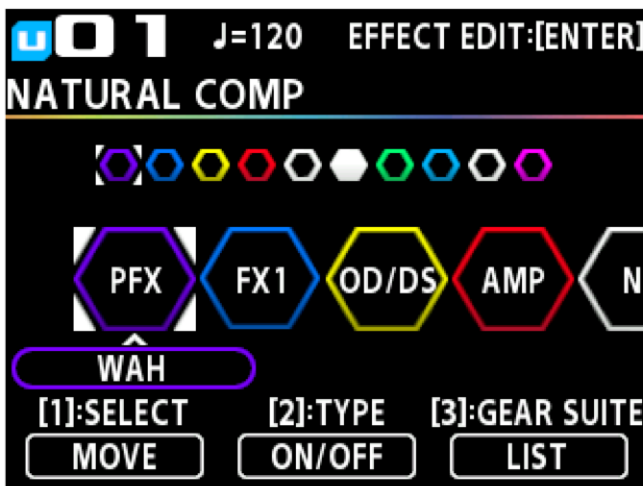

MEMO

You can also use the buttons for each effect to switch the effects on/off.

On

Off



2 Turn the [1] knob to choose the effect you're going to edit.

MEMO

For FX1, FX2, FX3, and PEDAL FX (PFX), turn the [2] knob while an effect is selected to switch between types.

3 Press the [2] knob to switch the selected effect on/off.

4 Press the [ENTER] button to open the edit screen.

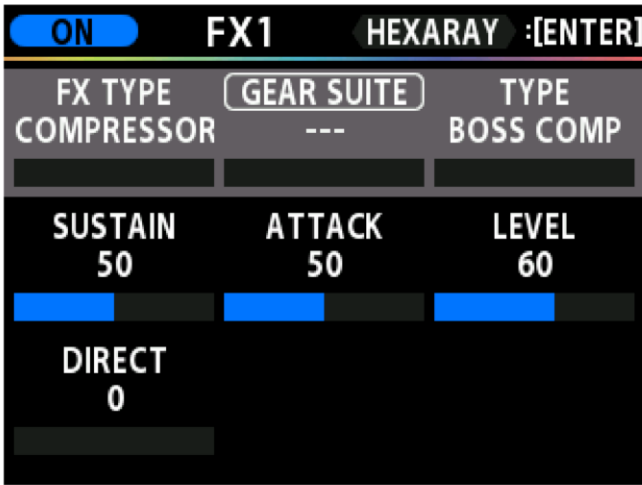

5 Use [1]–[3] knobs to specify the value of each parameter. You can use the [V][^] buttons to move the cursor.

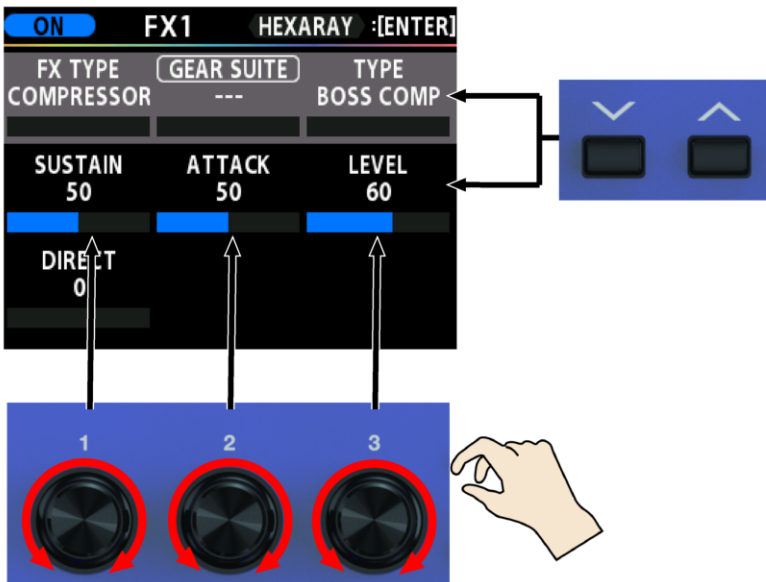

MEMO

To change a value in larger steps, turn a knob while pressing it.

6 Press the [EXIT] button a number of times to return to the play screen.

MEMO

If you wish to change the memory volume, turn the knob on the play screen to adjust the MEMORY LEVEL value.

Editing the effects from the play screen

You can edit effects not only from the effect chain screen but also from the [play screen](#) (p. 10).

- 1 Long-press the button of the effect you want to edit.



The edit screen appears.

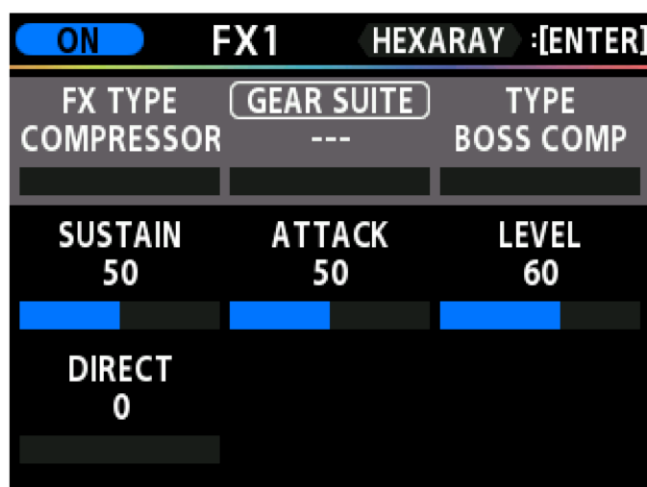

MEMO

Press an effect button to switch the effect on/off.

- 2 Turn knobs [1]-[3] to set the values for the parameters. You can use the [V] [^] buttons to move the cursor.

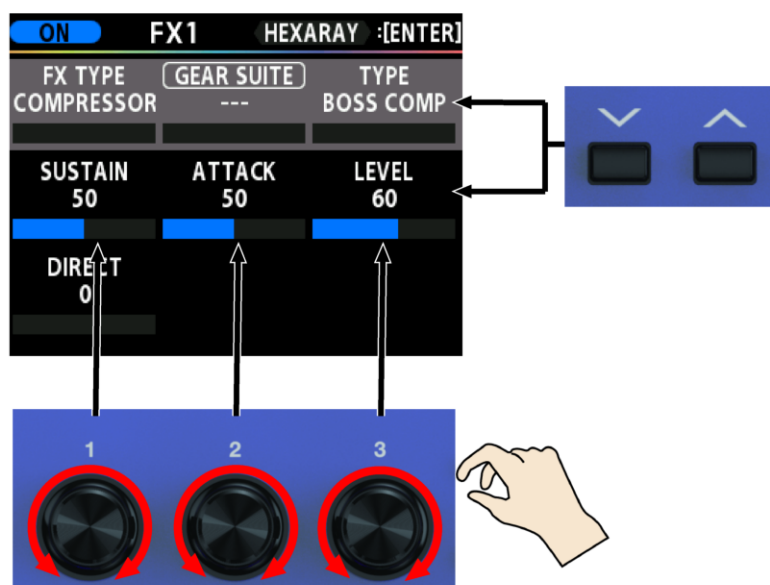

- 3 Press the [EXIT] button to return to the play screen.

About HEXARAY

When you press the [ENTER] button in the edit screen, the effect indicators work in HEXARAY mode.

This gives you a visual representation of the effects, levels, and other aspects of the effect to help you set each parameter.

MEMO

Press the [ENTER] button again to return to the on/off state of the effect.

Refer to the Parameter Guide for the HEXARAY types available for each effect.

HEXARAY types

Type name	Explanation
Level meter	Shows the effect's output level.
Reduction meter	Shows how much the effects such as a compressor are applied. The stronger the effect, the more indicators light up.
Sense meter	Shows the effect of settings such as the SENS parameter.
Tempo & stereo level meter	Shows the stereo signal level. Effects with a tempo setting have a blinking center indicator that shows the tempo.
Spectrum meter	Shows the frequency band levels using color and brightness.

Recalling recommended settings for each effect (GEAR SUITE)

The GX-1B features several recommended settings for each effect. The function used for easily recalling these settings is called “GEAR SUITE”. You can use this function to easily create sounds by combining settings for each effect, without having to adjust each effect’s parameters.

Recalling GEAR SUITE from the effect chain screen

MEMO

You can access GEAR SUITE from the edit screen of each effect.

1 Press the [EDIT] button.



The effect chain screen is shown.

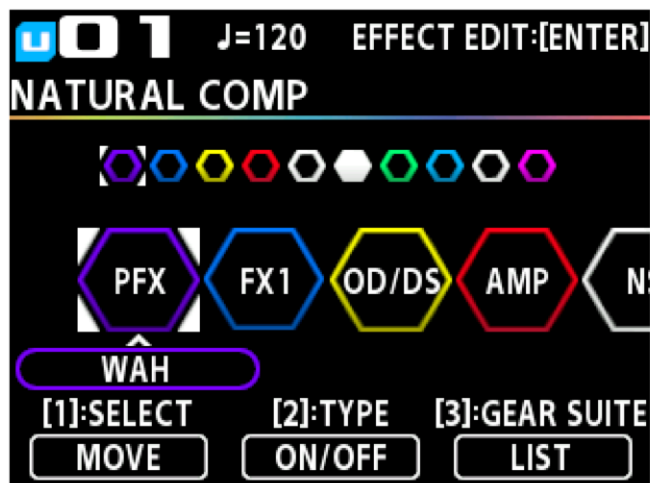

2 Turn the [1] knob to choose the effect you’re going to edit.

3 Turn the [3] knob to switch between the recommended settings for the selected effect.

Press the [3] knob to view a list of recommended settings.

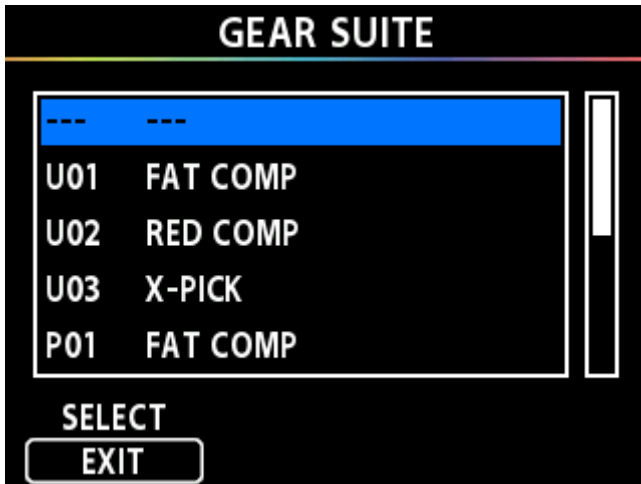

Press the [EXIT] button or [1] knob to return to the effect chain screen.

Editing the connection order for effects

You can select and move effects within the effect chain.

1 Press the [EDIT] button.

The effect chain screen is shown.

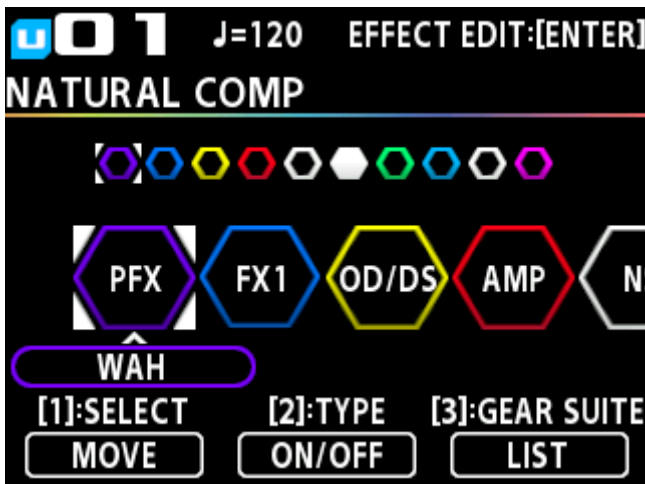

2 Turn the [1] knob to select the effect you want to move.

- 3 Press the [1] knob to make the selected effect movable.

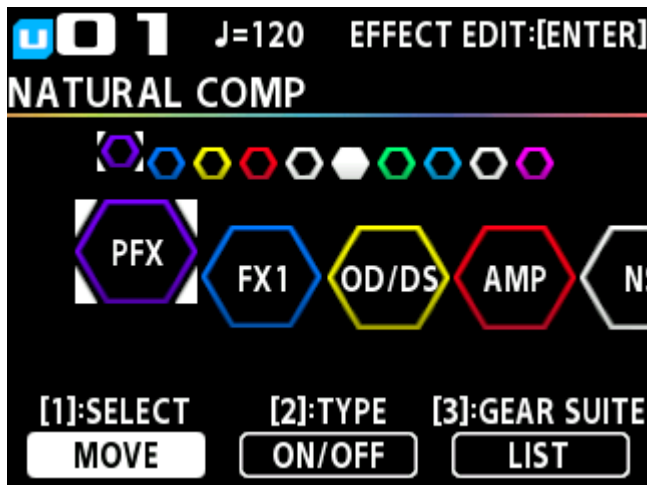

- 4 Turn the [1] knob to select where you want to move the effect.

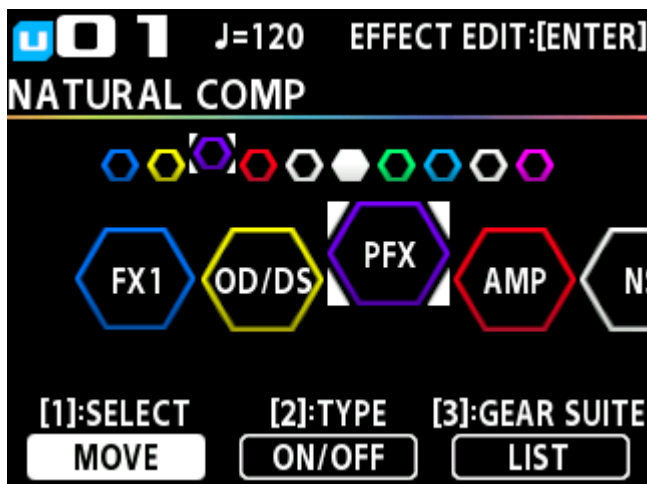

- 5 Press the [1] knob to confirm.

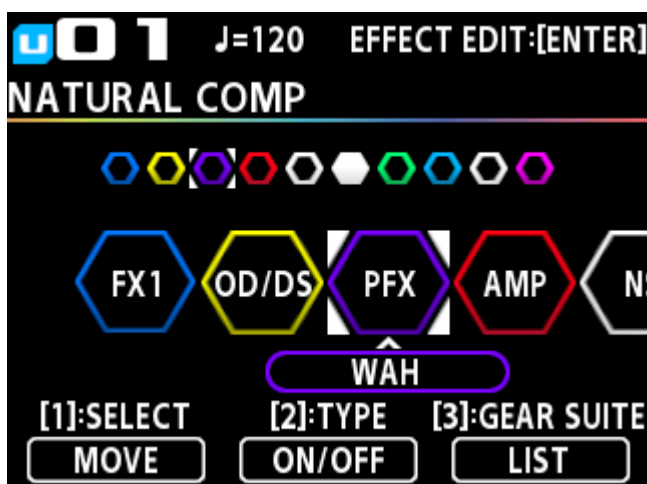

Switching memories without interrupting the sound

Tips for preventing interruptions in the sound

To prevent interruptions in the sound, observe the following points when you create the memories that are used before and after the switch.

Editing: Effects

- The same chain is used for both memories, both before and after switching.
- Set the same type of each effect block before and after the switch.

Example:

Switch from a clean chorus sound to a lead sound with distortion and delay.

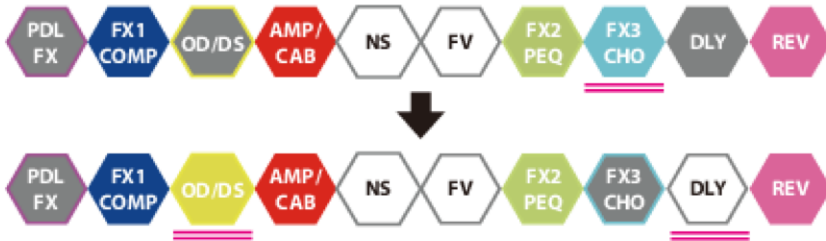

Making the effect sound (reverberations) carry over when you switch memories (carryover)

The function that preserves the tail of an effect (such as delay or reverb) when you switch to a different effect is called “carryover”.

1 Press the [EDIT] button.

The effect chain screen is shown.

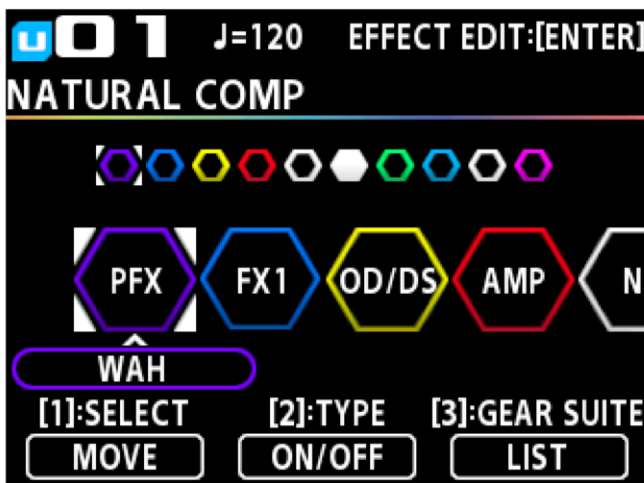

2 Turn the [1] knob to select the MASTER block (MST).

3 Press the [ENTER] button.

The edit screen appears.

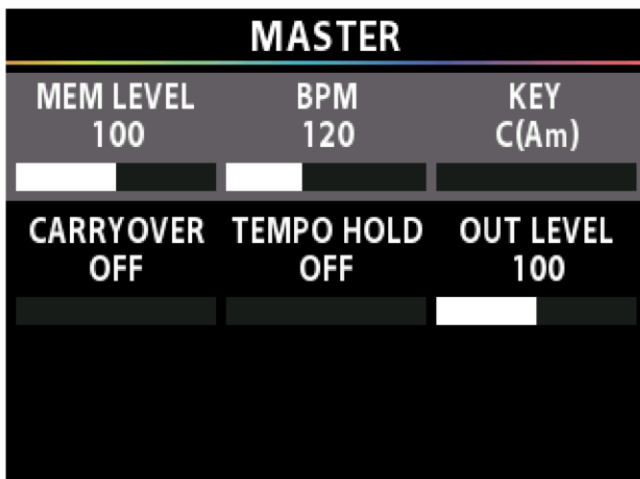

4 Press the [V][^] buttons to move the cursor to the “CARRY OVER” row.

5 Turn the [1] knob to set the CARRY OVER parameter to “ON”.

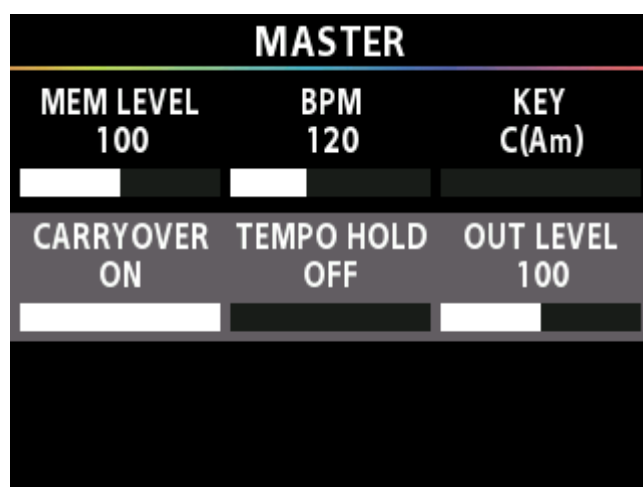

Conditions in which carryover is enabled

To enable the carryover of the delay or reverb (included in the memory that you used before switching) after you've switched to a different memory, make the following settings.

- On the preceding and on the following memories, configure the effect chain to use the same effect, and use the same arrangement. Set each effect type to be the same as well.
- On each memory, change the effect parameter settings and the on/off settings.

MEMO

The carryover sound, such as delay and reverb, changes according to the settings in the memory after switching. For a natural effect, we recommend that you use the same settings as the memory before switching.

Saving memories (WRITE)

When you want to save a memory you have created, save it as a user memory by following the procedure below. If you do not save the memory, the edited settings will be lost when you turn off the power or switch to another memory.

1 Press the [EXIT] button and [ENTER] button at the same time.

The WRITE MENU screen appears.

2 Press the [V][^] buttons to move the cursor to the "WRITE" row.

3 Press the [1] knob.

The MEMORY WRITE screen appears.

4 Turn the [1] knob to select the save destination (U01–U99).

5 Use the [2][3] knobs and [V][^] buttons to edit the memory name.

Operation	Function
Turn the [2] knob	Moves the cursor
Press the [2] knob	Deletes one character (delete)
Turn the [3] knob	Change the character type
Press the [3] knob	Inserts one space (insert)
Press the [V][^] buttons	Switches uppercase/lowercase

6 Press the [ENTER] button.

The play screen will be displayed after saving is complete.

List of WRITE MENU functions

Menu	Function
WRITE	Saves the memory you created.
EXCHANGE	You can "swap" or exchange the positions of two User memories.
INITIALIZE	You can restore (initialize) each effect in a user memory to its standard settings. This is useful when you want to create a new memory from scratch.
MEMORY ORDER	You can change the order of memories U01–U99.

Saving as a GEAR SUITE

You can save the settings of your favorite effects as a GEAR SUITE.

1 Switch to the memory containing your favorite effect settings.

2 Press the [EXIT] button and [ENTER] button at the same time.

The WRITE MENU screen appears.

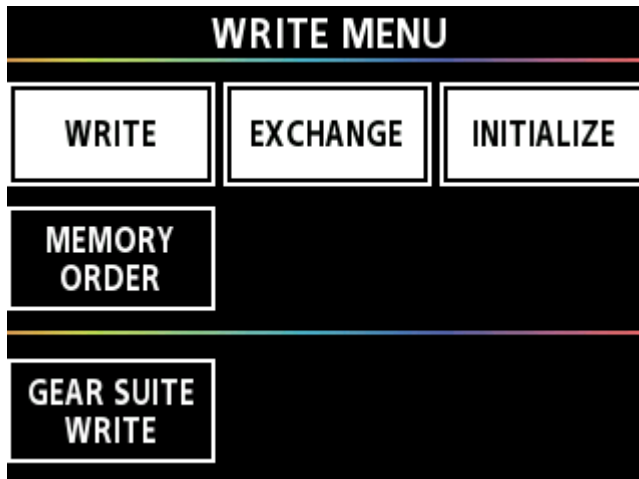

3 Press the [V][^] buttons to move the cursor to the "GEAR SUITE WRITE" row.

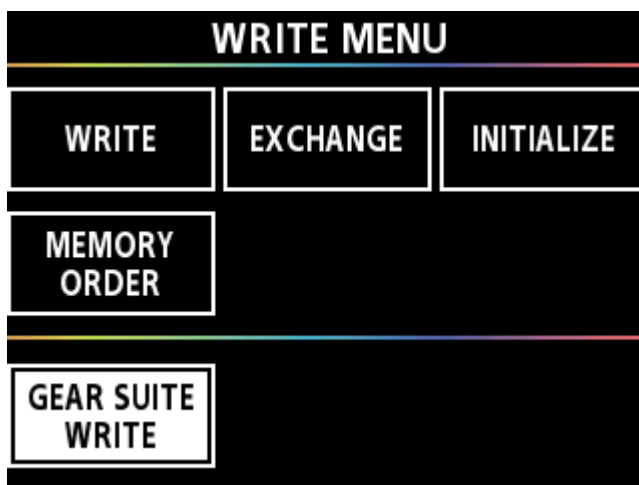

4 Press the [1] knob.

The GEAR SUITE WRITE screen appears.

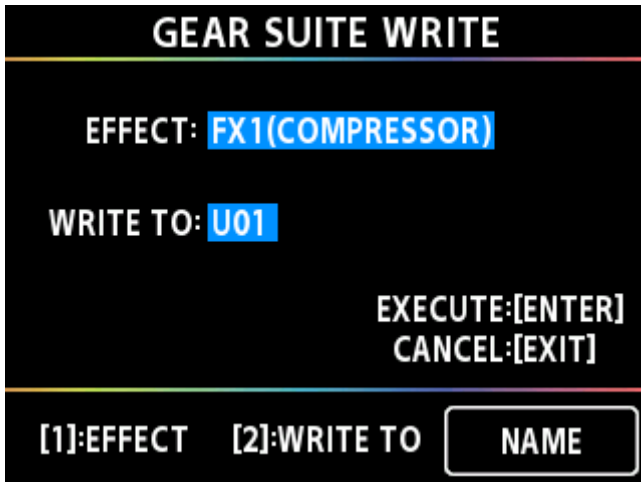

5 Turn the [1] knob to select the effect block you want to save.

6 Use knob [2] to select the save-destination.

The maximum number of effect blocks you can save depends on the effect type.

7 Press the [3] knob to display a screen where you can change the name of the GEAR SUITE.

Enter a name for the GEAR SUITE you want to save.

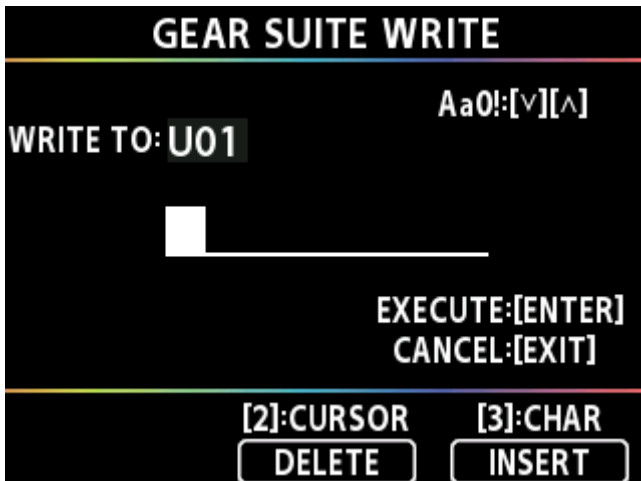

You can input up to 8 characters.

Operation	Function
Turn the [2] knob	Moves the cursor
Press the [2] knob	Deletes one character (delete)
Turn the [3] knob	Change the character type
Press the [3] knob	Inserts one space (insert)
Press the [v][^] buttons	Switches uppercase/lowercase

8 Press the [ENTER] button.

The GEAR SUITE is saved.

When the save is complete, the write menu screen appears.

Swapping Memories (MEMORY EXCHANGE)

You can “swap” or exchange the positions of the user memories to change their order.

1 From the play screen, press the [▼][▲] switches to display the user memory you want to move.

The user memory to be exchanged is the one that’s displayed.

2 Press the [EXIT] button and [ENTER] button at the same time.

The WRITE MENU screen appears.

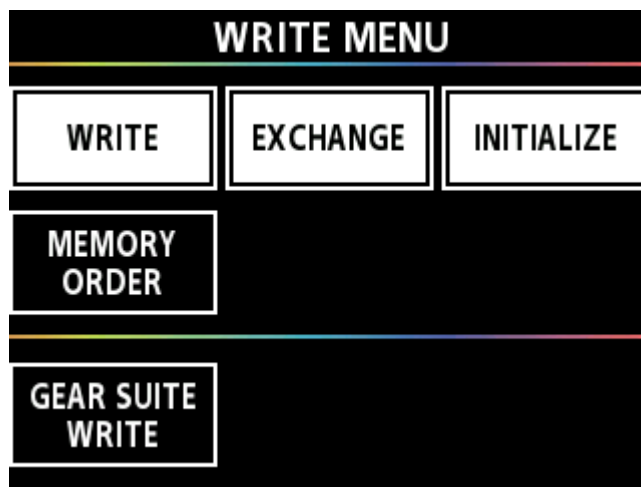

3 Press the [▼][▲] buttons to move the cursor to the [EXCHANGE] row.

4 Press the [2] knob.

The MEMORY EXCHANGE screen appears.

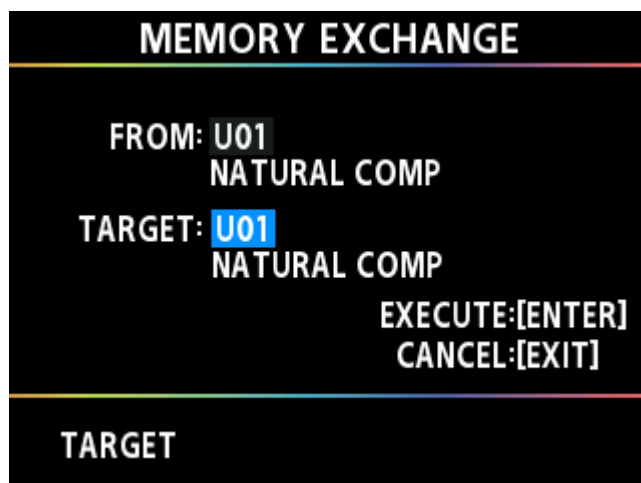

5 Turn the [1] knob to select the swap destination memory.

6 Press the [ENTER] button.

A confirmation message appears.

7 Press the [V][^] buttons to move the cursor to OK and press the [ENTER] button.

The message "EXECUTING..." is shown on the screen. When the operation is complete, the order of the memories is updated and saved.

Changing the order of memories (MEMORY ORDER)

You can change the order of the user memories.

1 Press the [EXIT] button and [ENTER] button at the same time.

The WRITE MENU screen appears.

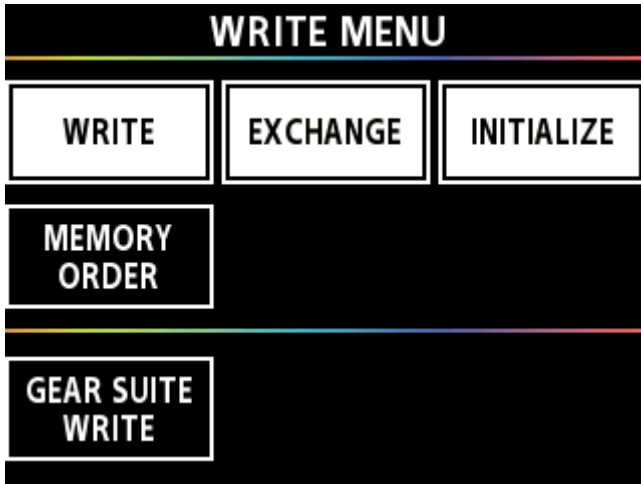

2 Press the [V][^] buttons to move the cursor to the row where [MEMORY ORDER] is shown.

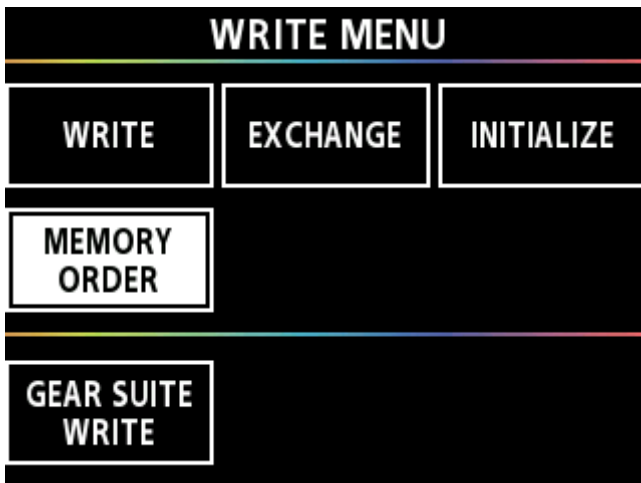

3 Press the [1] knob.

The MEMORY ORDER screen appears.

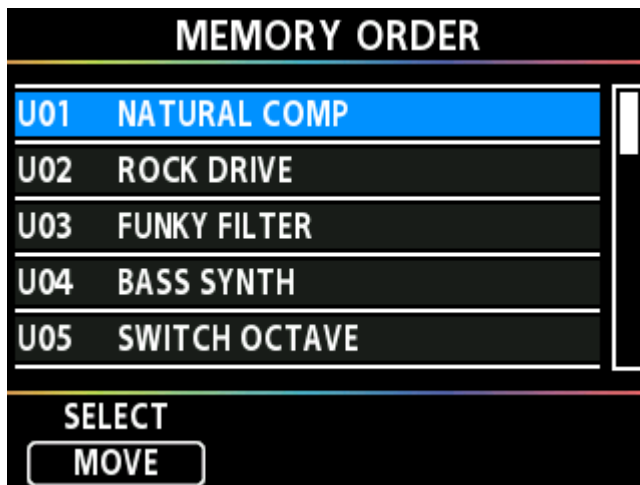

4 Turn the [1] knob to move the cursor to the memory you want to sort.

5 Press the [1] knob to select the memory.

The highlight color of the selected memory changes from blue to orange.

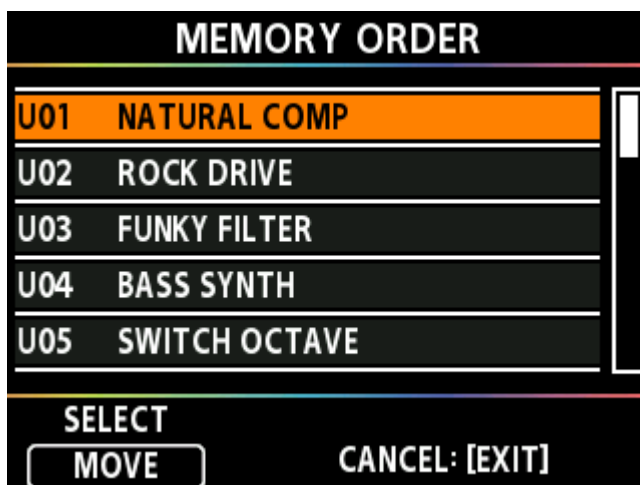

6 Turn the [1] knob to select where to move the memory.

7 Press the [1] knob to confirm where to move the memory.

The highlight color changes from orange to blue, and you can now move other memories.

At this stage, the sorting is not yet complete.

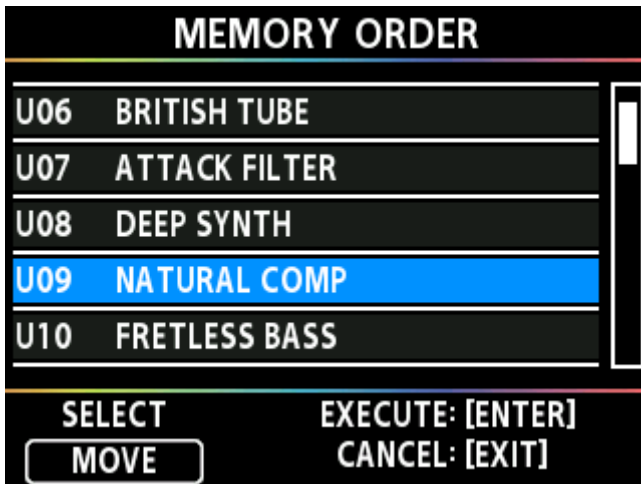

8 Repeat steps 4–7 to edit the memory order.

9 Once the memories are in order, press the [ENTER] button.

The message "EXECUTING..." is shown on the screen. When the operation is complete, the order of the memories is updated and saved.

Initializing memories (MEMORY INITIALIZE)

This initializes the selected user memory. This is useful when creating a sound from scratch.

1 Press the [EXIT] button and [ENTER] button at the same time.

The WRITE MENU screen appears.

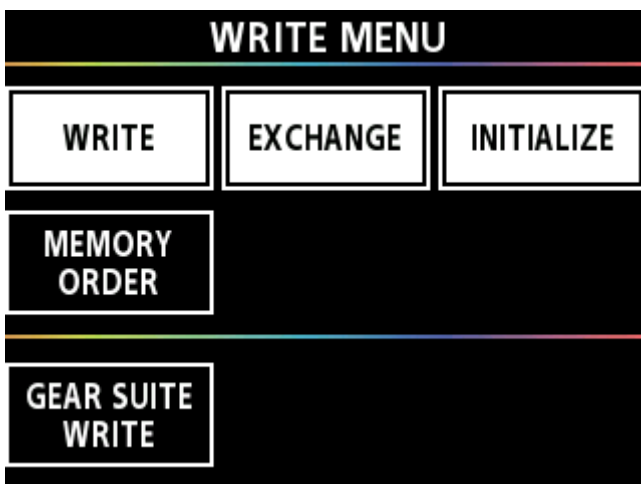

2 Press the [v] [^] buttons to move the cursor to the row where [INITIALIZE] is shown.

3 Press the [3] knob.

The MEMORY INITIALIZE screen appears.

4 Turn the [1] knob to select the memory you want to initialize.

5 Press the [ENTER] button.

A confirmation message appears.

6 Press the [V][^] buttons to move the cursor to OK and press the [ENTER] button.

The message "EXECUTING..." is shown on the screen. When the operation is complete, the memory is initialized and saved.

Editing: MENU

This section explains how to make settings that are common to the entire GX-1B (system parameters).

Here's where we configure the output and **BLUETOOTH**® settings, the various USB settings, the function assignments for the [1]–[3] knobs and so forth.

For details on the parameters, refer to the "GX-1B Parameter Guide" (BOSS website).

Basic menu operations

- 1 Press the [MENU] button.

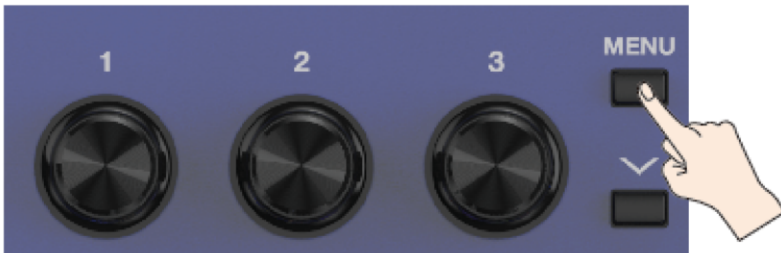

- 2 Use the [V][^] buttons to move the cursor.

- 3 Press one of the knobs [1]–[3] to select the item that you want to edit.

A sub-menu may appear depending on the item you touch. Select the parameter to set.

- 4 Set the values for the various parameters.

- 5 When you're finished editing, press the [EXIT] button to return to the play screen.

Assigning the desired parameters to knobs [1]–[3] (KNOB SETTING)

Here's how to assign the parameters that are controlled by the [1]–[3] knobs when the play screen is shown.

- 1 Press the [MENU] button.

- 2 Press the [V][^] buttons to move the cursor to the "KNOB SETTING" row.

- 3 Press the [3] knob.

The KNOB SETTING screen appears.

KNOB SETTING		
	CATEGORY	PARAMETER
1	MEMORY	NUMBER
2	MEMORY	LEVEL
3	OUTPUT	LEVEL

[1]:SELECT [2]:CATEGORY [3]:PARAMETER

4 Turn the [1] knob to select the knob you want to set.

The highlight moves up and down.

5 Use the [2] knob to select the category, and turn the [3] knob to change the parameter to assign.

Setting the colors for the display and footswitches

This function includes the settings for the colors of the display and the LED indicators.

These parameters are common settings for all memories.

1 Press the [MENU] button.

2 Press the [V][^] buttons to move the cursor to the "HARDWARE SETTING" row.

3 Press the [1] knob.

The HARDWARE SETTING screen appears.

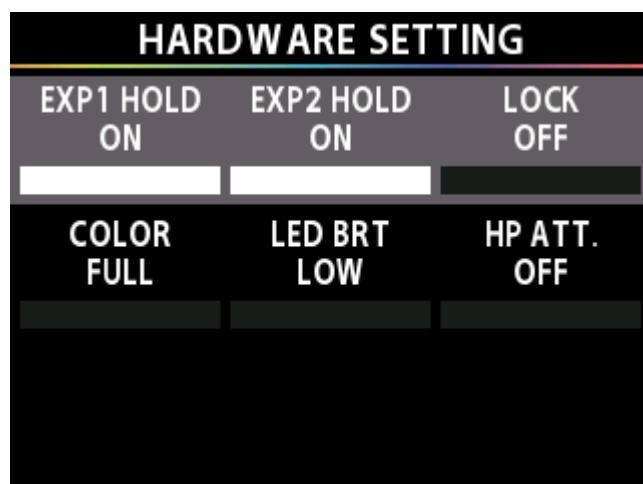

4 Press the [V][^] buttons to move the cursor to the "COLOR" row.

5 Turn the [1] knob to select the color display setting.

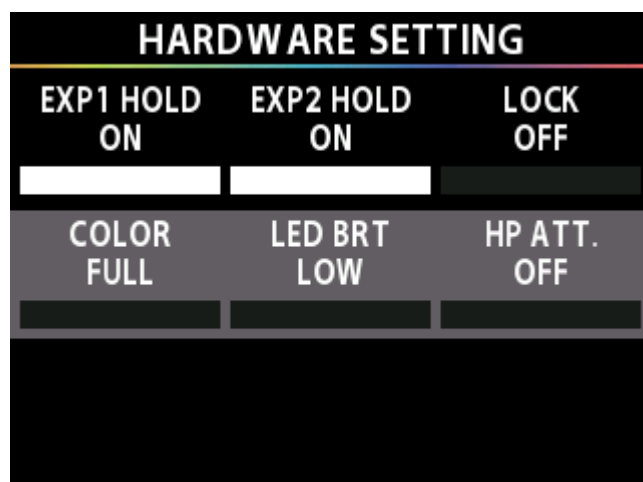

Value	Explanation
FULL	<p>The screen displays in color.</p> <p>The LED indicator colors change depending on the effect type and so on.</p>
RED	<p>The screen displays in black and white.</p> <p>The LED indicators basically display in red.</p> <p>When a function is used for which the color change is necessary, the colors yellow, blue and white are used to make the state easy to distinguish.</p>
BLUE	<p>The screen displays in black and white.</p> <p>The LED indicators basically display in blue.</p> <p>When a function is used for which the color change is necessary, the colors red, yellow and white are used to make the state easy to distinguish.</p>
GREEN	<p>The screen displays in black and white.</p> <p>The LED indicators basically display in green.</p> <p>When a function is used for which the color change is necessary, the colors red, yellow, blue and white are used to make the state easy to distinguish.</p>
YELLOW	<p>The screen displays in black and white.</p> <p>The LED indicators basically display in yellow.</p> <p>When a function is used for which the color change is necessary, the colors red, blue and white are used to make the state easy to distinguish.</p>
ORANGE	<p>The screen displays in black and white.</p> <p>The LED indicators basically display in orange.</p> <p>When a function is used for which the color change is necessary, the colors red, yellow, blue and white are used to make the state easy to distinguish.</p>
PINK	<p>The screen displays in black and white.</p> <p>The LED indicators basically display in pink.</p> <p>When a function is used for which the color change is necessary, the colors red, yellow, blue and white are used to make the state easy to distinguish.</p>
PURPLE	<p>The screen displays in black and white.</p> <p>The LED indicators basically display in purple.</p> <p>When a function is used for which the color change is necessary, the colors red, yellow, blue and white are used to make the state easy to distinguish.</p>
LIGHT BLUE	<p>The screen displays in black and white.</p> <p>The LED indicators basically display in light blue.</p> <p>When a function is used for which the color change is necessary, the colors red, yellow, blue and white are used to make the state easy to distinguish.</p>
CYAN	<p>The screen displays in black and white.</p> <p>The LED indicators basically display in cyan.</p> <p>When a function is used for which the color change is necessary, the colors red, yellow, blue and white are used to make the state easy to distinguish.</p>

Value	Explanation
WHITE	<p>The screen displays in black and white.</p> <p>The LED indicators basically display in white.</p> <p>When a function is used for which the color change is necessary, the colors red, yellow and blue are used to make the state easy to distinguish.</p>

Restoring the factory settings (factory reset)

Restoring the GX-1B's settings to their original factory settings is referred to as "Factory Reset". You can restore all of the settings to their factory-set values, and you can also specify certain items to be reset.

* When you execute factory reset, the settings you made are lost. Save the data you need to your computer or mobile device using the dedicated software.

- 1 Press the [MENU] button.
- 2 Press the [V][^] buttons to move the cursor to the "UTILITY" row.
- 3 Use the [3] knob to select "UTILITY".

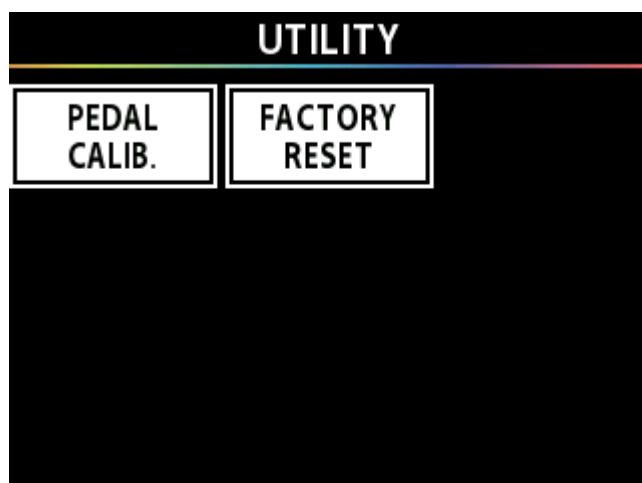

- 4 Press the [2] knob and select "FACTORY RESET".

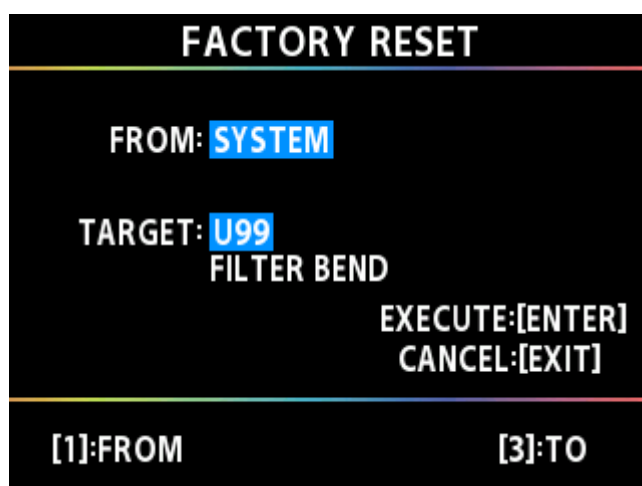

- 5 Specify the factory reset range by using the [1] and [3] knobs to set <FROM> and <TO>.

	Knob	Parameter	Value	Explanation
[1]		FROM	SYSTEM	System parameter settings
[3]		TO	U01-U99	Settings for memory numbers U01 through U99

6 Press the [ENTER] button.

A confirmation message appears.

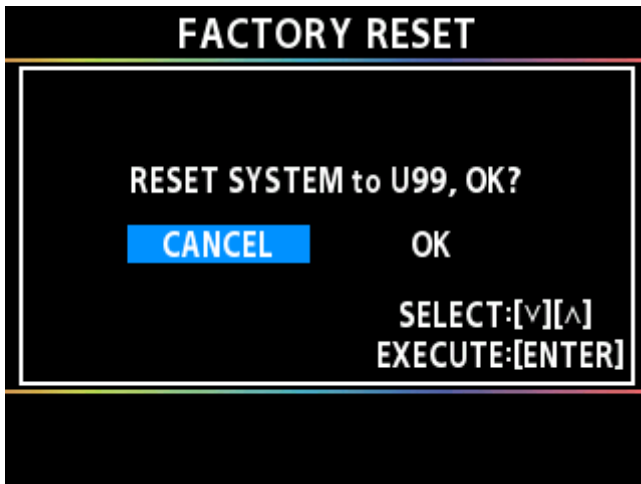

7 To execute the factory reset, press the [V][^] buttons and select "OK", and then press the [ENTER] button to execute the factory reset.

To cancel the factory reset, press the "CANCEL" button, and then press the [ENTER] button.

Once the Factory Reset is complete, the unit returns to the Play screen.

Connecting to a computer

By connecting the GX-1B to a computer via USB, you can do the following.

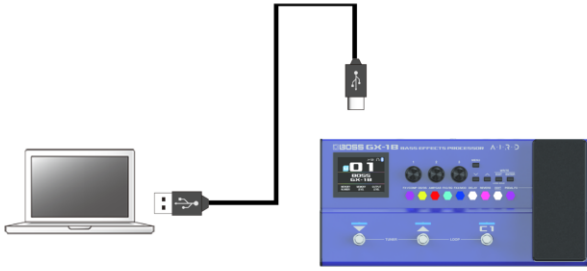

- Transmit and receive digital audio and MIDI signals between the computer and this unit
- Edit and manage memories, and display the “GX-1B Parameter Guide” (BOSS website) on a computer using the dedicated software
- Download memories from the BOSS TONE EXCHANGE dedicated website

<https://bosstoneexchange.com/>

Installing the USB Driver

You must install the USB driver before connecting to a computer.

Download the USB driver from the website shown below.

<https://www.boss.info/support/>

The program you need to use, and the steps you need to take to install the USB driver will differ depending on your computer setup, so please carefully read and refer to the Readme.htm file that comes with the download.

Using this unit as an Audio Interface

You can record the sound of the GX-1B on your computer, or output the sound from your computer via the OUTPUT jacks of the GX-1B.

* Refer to the instruction manual for the software you are using to learn how to switch the input source of the software.

Making use of the GX-1B’s dedicated software

Download the BOSS TONE STUDIO for GX-1B dedicated software from the BOSS website.

For details on how to use the software, refer to the Readme.htm file that comes with the download.

<https://www.boss.info/support/>

Using the dedicated software allows you to do the following:

- Easily download memories from the BOSS TONE EXCHANGE download website into this unit
- Edit memory settings
- You can assign a name to a memory.
- Organize memories in order and switch them around
- Back up memories and system settings, and return to the backed up settings
- Upload memories you created and share them with other users
- You can bring up the manuals for this unit, including the “GX-1B Startup Guide” (BOSS website), the “GX-1B Reference Manual” (this manual) and the “GX-1B Parameter Guide” (BOSS website).

Connecting the mobile device

By connecting the GX-1B to a mobile device via USB, you can use the unit as an audio interface.

Using this unit to hear audio played from a mobile device

- 1 Press the [MENU] button.
- 2 Press the [V][^] buttons to move the cursor to the “USB” row.
- 3 Press knob [1] and select “USB”.

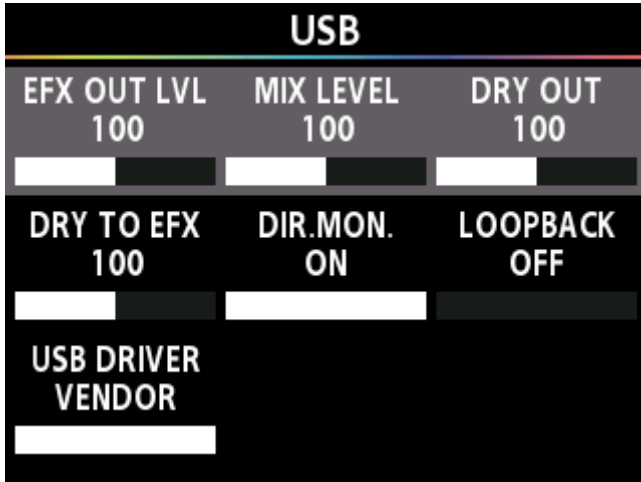

- 4 Press the [V][^] buttons to move the cursor to the “USB DRIVER” row.
- 5 Turn the [1] knob to select “GENERIC”.

If this is set to “VENDOR”, you can’t connect the mobile device.

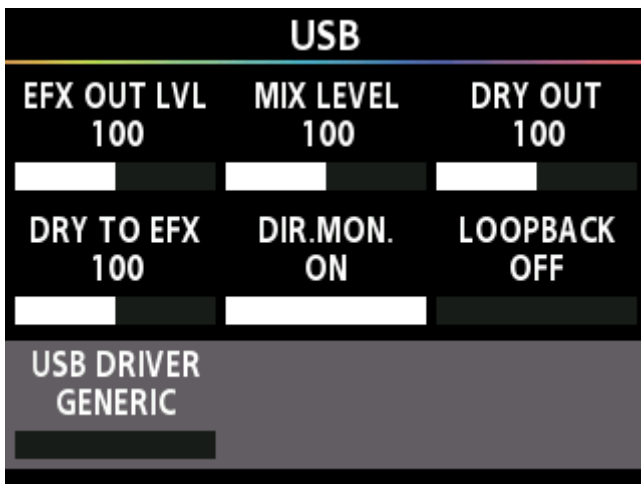

- 6 Use the USB cable to connect the GX-1B to your mobile device.

NOTE

The app might not work in tandem with your device, depending on the mobile device you’re connected to, as well as the specifications of the app you’re using to play back music.

Mixing the sound of the song playing back on your mobile device with the sound of your bass playing

- 1 Press the [MENU] button.
- 2 Press the [V][^] buttons to move the cursor to the "USB" row.
- 3 Press knob [1] and select "USB".

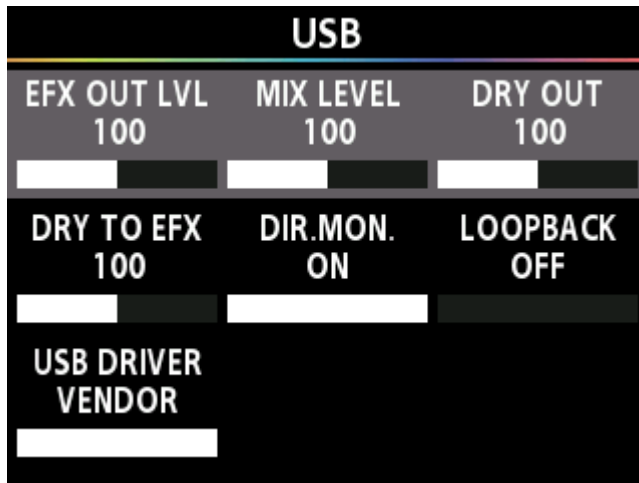

- 4 Press the [V][^] buttons to move the cursor to the "USB DRIVER" row.
- 5 Turn the [1] knob to select "GENERIC".

If this is set to "VENDOR", you can't connect the mobile device.

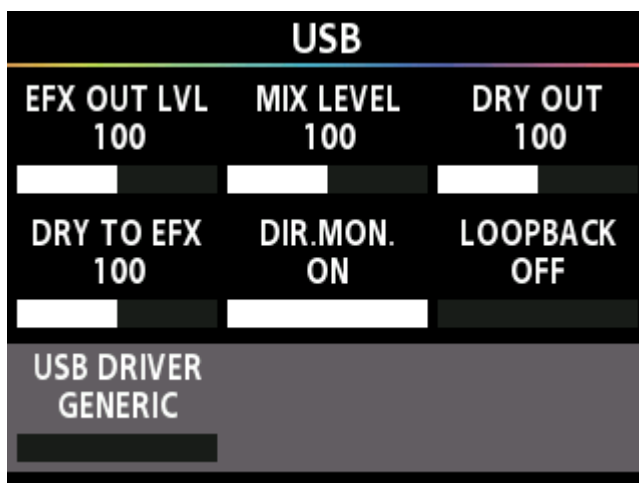

- 6 Press the [V][^] buttons to move the cursor to the "LOOP BACK" row.

7 Turn the [3] knob to select “ON”.

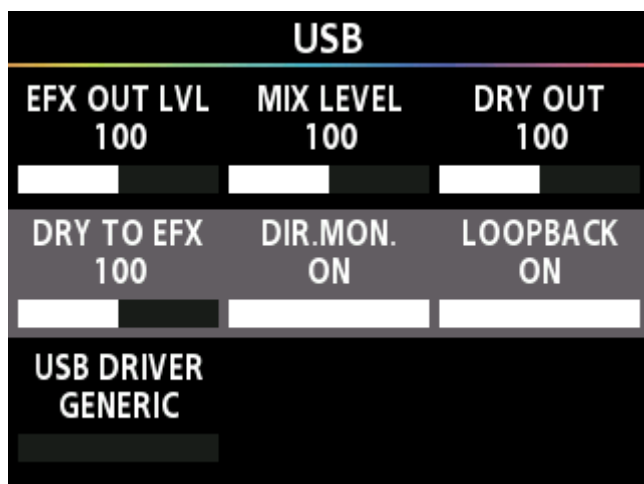

8 Use the USB cable to connect the GX-1B to your mobile device.

NOTE

The app might not work in tandem with your device, depending on the mobile device you're connected to, as well as the camera app and the specifications of the app you're using to play back music.

Wireless connection with a mobile device

You can wirelessly play back music on your mobile device, or edit the effects of this unit from the app on your mobile device.

Listening to sound from a wirelessly connected mobile device (Bluetooth® audio)

Bluetooth® audio functionality

You can output music played from your Bluetooth audio-capable mobile device from the OUTPUT jacks or the PHONES jack of the GX-1B.

Registering a Mobile Device (Pairing)

“Pairing” involves registering the mobile device that you want to use with the GX-1B (making the two devices recognize each other).

Here we’ll configure the settings so that music data saved on your mobile device can be played wirelessly via the GX-1B.

MEMO

The following explanation is only one example. For details, refer to the owner’s manual of your mobile device.

- 1 Turn on the power of the GX-1B.**
- 2 Place the mobile device that you want to connect close to the GX-1B.**
- 3 Press the [MENU] button.**
- 4 Press the [V][^] buttons to move the cursor to the “Bluetooth” row.**
- 5 Turn the [3] knob to select “Bluetooth”.**

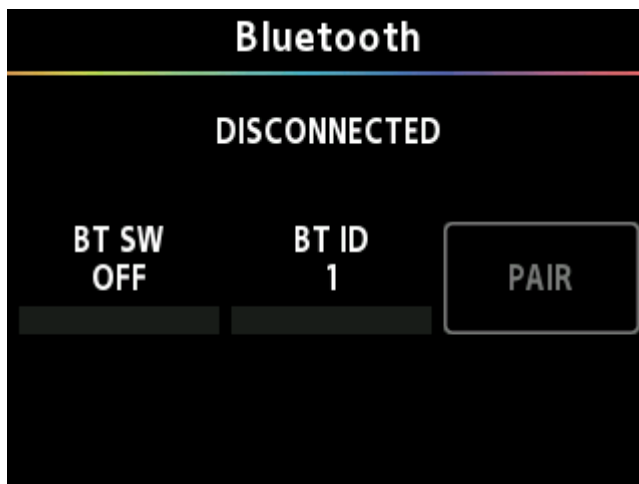

6 Turn the [1] knob to turn the BT SW on.

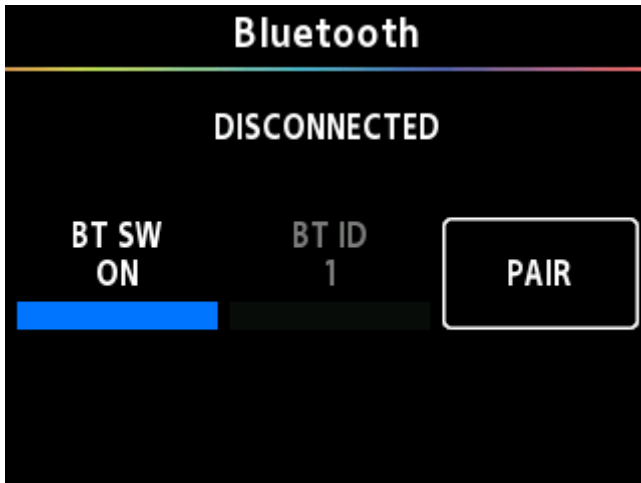

7 Press the [3] knob (PAIR) to activate pairing standby mode.

The screen of the GX-1B shows "Pairing".

If you don't pair the unit within a certain amount of time, pairing standby mode is canceled.

8 Turn on the Bluetooth function of the mobile device.



9 Tap "GX-1B Audio", shown on the Bluetooth device screen of your mobile device.

This pairs the GX-1B with your mobile device. When pairing succeeds, "GX-1B Audio" is added to the list of paired devices on your mobile device.

AUDIO: ○ is shown on the GX-1B display.

MEMO

If you turn the [1] knob and set BT SW to "OFF" while Bluetooth is connected, the connection is temporarily severed.

Set BT SW to "ON" to reconnect. When unpairing, delete the registration data on your mobile device.

Controlling the unit from a mobile device app

Use the "BOSS TONE STUDIO for GX-1B" app to edit effects and save settings on this unit.

For details on the BOSS TONE STUDIO for GX-1B, see the BOSS website.

<https://www.boss.info/support/>

Connecting to the App

* Make the connection from the app's settings, not from your mobile device's Bluetooth settings.

- 1 Turn on the power of the GX-1B.**
- 2 Place the mobile device that you want to connect close to the GX-1B.**
- 3 Turn on the Bluetooth function of the mobile device.**



- 4 Press the [MENU] button.**
- 5 Press the [V][^] buttons to move the cursor to the "Bluetooth" row.**
- 6 Press the [3] knob.**

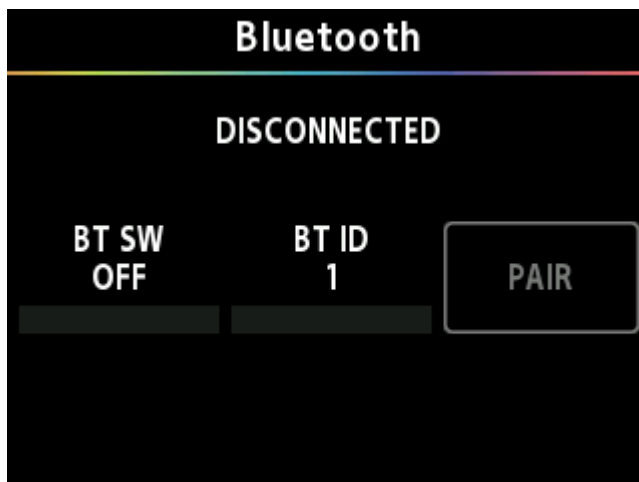

7 Turn the [1] knob to turn the BT SW on.

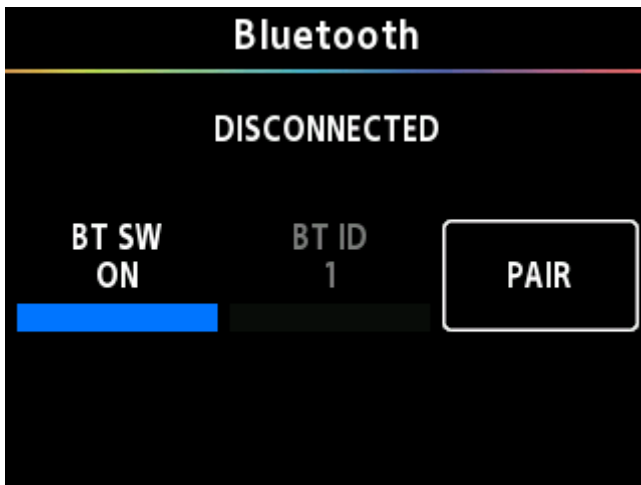

8 In the app's settings, connect to GX-1B MIDI.

Once the connection is complete, MIDI:○ is displayed on the GX-1B screen.

NOTE

Do not tap "GX-1B MIDI" if you see it in the Bluetooth settings of your mobile device. If you tapped this, temporarily cancel the device registration, and perform the procedure again from step 3.

Footswitch and expression pedal settings

You can assign a variety of functions to the top panel [CTL1] (C1) switch, the expression pedal (EXP1), and the expression pedal or footswitch connected to the rear panel CTL 2, 3/EXP 2 jack.

Setting example 1: assigning an ON/OFF toggle for AMP SOLO to the [CTL1] (C1) switch

1 Press the [MENU] button.

2 Press the [V][^] buttons to move the cursor to the “CTL FUNC” row.

MENU		
OUTPUT SELECT	GLOBAL EQ	Bluetooth
CTL FUNC	ASSIGN	KNOB SETTING
USB	LOOP SETTING	PLAY OPTION
HARDWARE		

3 Press the [1] knob.

4 Use the [1]–[3] knobs or the [V][^] buttons to move the cursor to the “CTL1” row.

CTL FUNC		
▼SW	▲SW	CTL1
CTL2	CTL3	EXP1 SW
EXP1	EXP2	EV-1-WL FS-1-WL

5 Press the [3] knob.

The [CTL1] (C1) settings screen appears.

Press the [v] [^] buttons to switch to the settings page for other controllers.

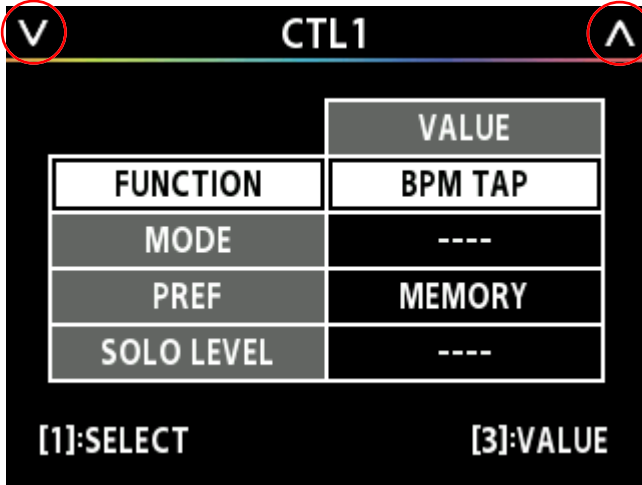

6 Turn the [1] knob to move the cursor to "FUNCTION", and turn the [3] knob to set the VALUE to "AMP SOLO".

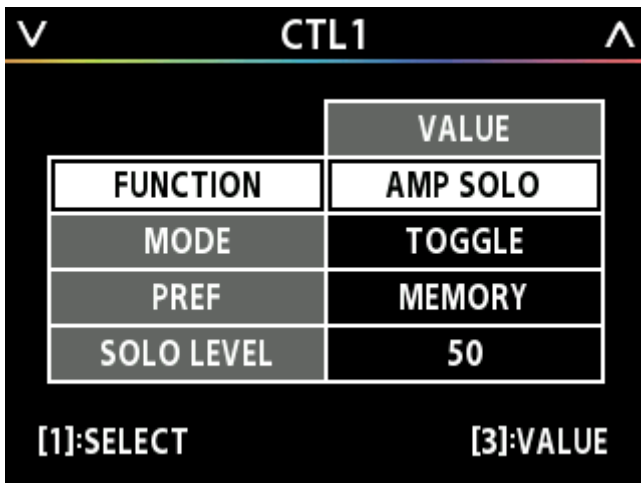

7 Turn the [1] knob to move the cursor to SOLO LEVEL, and turn the [3] knob to edit the VALUE.

The value set for SOLO LEVEL is the volume when SOLO is on.

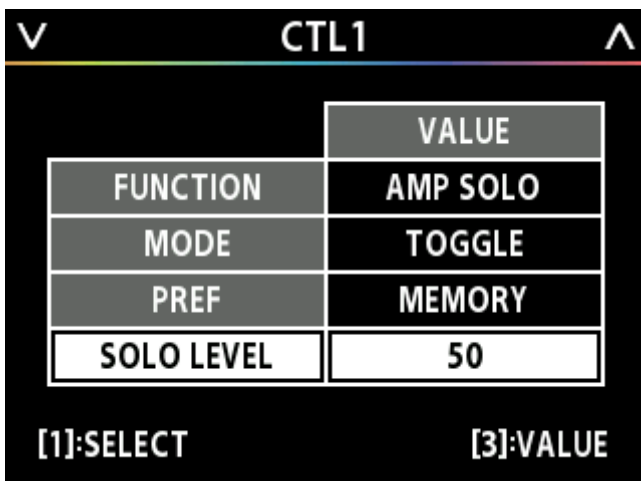

MEMO

Try pressing the [CTL1] (C1) switch on this screen to switch AMP SOLO on/off. Turn AMP SOLO on to switch to a sound that's suitable for soloing.

- The footswitch and expression pedal functions must be specified for each memory; however, if you set "PREF (PREFERENCE)" to SYSTEM, all memories will use those functions in common. When PREF is set to MEMORY, you can execute the WRITE operation to save the data.
- For details on the parameters, refer to the "GX-1B Parameter Guide" (BOSS website).

Setting example 2: assigning the PEDAL FX ON/OFF switch to the EXP1 switch, and the PEDAL FX control to EXP1

The EXP1 switch is activated when you press down hard on the toe of the [EXP1] pedal.

When you've finished making the settings, you can control the following.

- When PEDAL FX is off, you can operate the [EXP1] pedal to control the foot volume.
- When you strongly press the toe of the [EXP1] pedal, PEDAL FX turns on, and you can operate the [EXP1] pedal to control the PEDAL FX effect. When PEDAL FX is set to WAH, you can operate the [EXP1] pedal to adjust the wah depth.

MEMO

To change the PEDAL FX effect, you must make separate settings. Refer to [Basic procedure for effect editing \(p. 13\)](#).

1 Press the [MENU] button.

2 Press the [V][^] buttons to move the cursor to the "CTL FUNC" row.

MENU		
OUTPUT SELECT	GLOBAL EQ	Bluetooth
CTL FUNC	ASSIGN	KNOB SETTING
USB	LOOP SETTING	PLAY OPTION
HARDWARE		

3 Press the [1] knob.

4 Use the [1]–[3] knobs or the [V][^] buttons to move the cursor to the “EXP1 SW” row.

CTL FUNC		
▽SW	▲SW	CTL1
CTL2	CTL3	EXP1 SW
EXP1	EXP2	EV-1-WL FS-1-WL

5 Press the [3] knob.

The EXP1 SW settings screen appears.

6 Turn the [1] knob to move the cursor to “FUNCTION”, and turn the [3] knob to set the VALUE to “PEDAL FX”.

EXP1 SW	
	VALUE
FUNCTION	PEDAL FX
MODE	TOGGLE
PREF	MEMORY
SOLO LEVEL	----

[1]:SELECT [3]:VALUE

7 Press the [V][^] buttons to open the EXP1 settings screen.

8 Turn the [3] knob to set the FUNCTION to “FV+TU/PDL FX”.

EXP1	
	VALUE
FUNCTION	FV+TU/PDL FX
MODE	----
PREF	MEMORY
SOLO LEVEL	----

[1]:SELECT [3]:VALUE

Adjusting the expression pedal (pedal calibration)

Although this unit's expression pedal has been set for optimum operation at the factory, extended use and the operating environment can result in the pedal going out of adjustment.

If you encounter problems such as being unable to fully cut off the sound with the volume pedal or being unable to switch the PEDAL FX, you can use the following procedure to readjust the pedal.

- 1 Press the [MENU] button.
- 2 Press the [V][^] buttons to move the cursor to the "UTILITY" row.

MENU		
SELECT	EQ	
CTL FUNC	ASSIGN	KNOB SETTING
USB	LOOP SETTING	PLAY OPTION
HARDWARE SETTING	INFO.	UTILITY

- 3 Press the [3] knob.

UTILITY	
PEDAL CALIB.	FACTORY RESET

4 Press the [1] knob.

The PEDAL CALIBRATION screen appears.

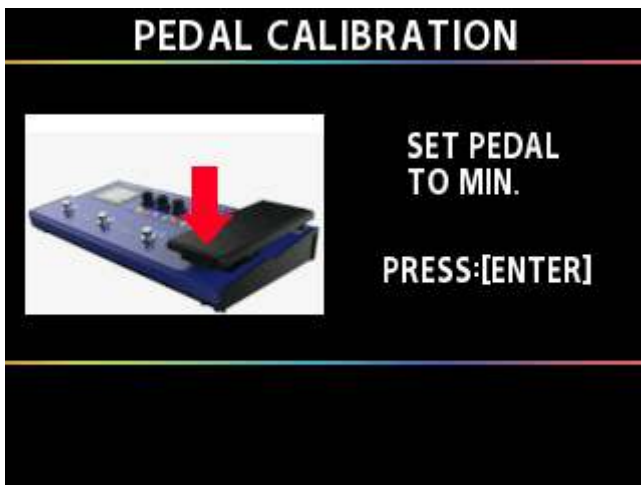

5 Press the toe end of the pedal, and press the [ENTER] button.

The screen will indicate "OK," and then a screen like the following will appear.



6 Press the toe end of the pedal, and press the [ENTER] button.

The screen will indicate "OK," and then a screen like the following will appear.

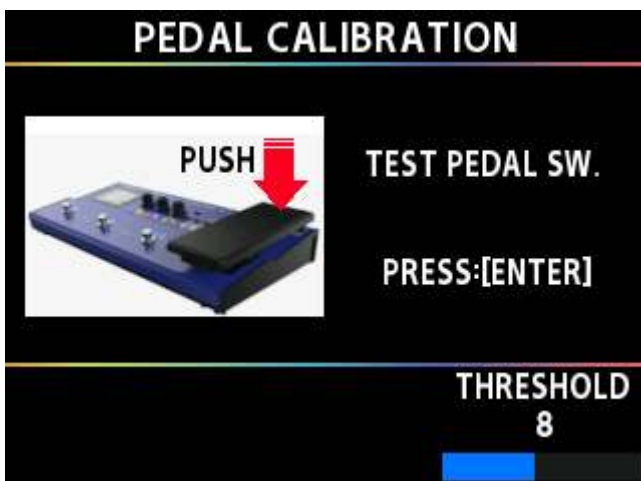

7 Strongly press the toe end of the pedal.

Verify that the PEDAL FX indicator lights when you strongly press the toe end.

If you want to change the lighting sensitivity of the PEDAL FX indicator, adjust the THRESHOLD value using knob [3], and repeatedly press the toe of the pedal firmly until you reach the desired sensitivity.

8 Press the [ENTER] button.

The message "COMPLETED!" is shown on the screen.

* When you operate the expression pedal, please be careful not to get your fingers pinched between the movable part and the panel. In places where small children are present, make sure that an adult provides supervision and guidance.

Connecting external pedals

- * To prevent malfunction and equipment failure, always turn down the volume, and turn off all the units before making any connections.
- * When you operate the expression pedal, please be careful not to get your fingers pinched between the movable part and the panel. In places where small children are present, make sure that an adult provides supervision and guidance.
- * When connecting an external expression pedal, use only the recommended pedals. Connecting expression pedals made by third-party manufacturers may cause this unit to malfunction. Expression pedals you can use (sold separately): EV-30, FV-500L, FV-500H, Roland EV-5

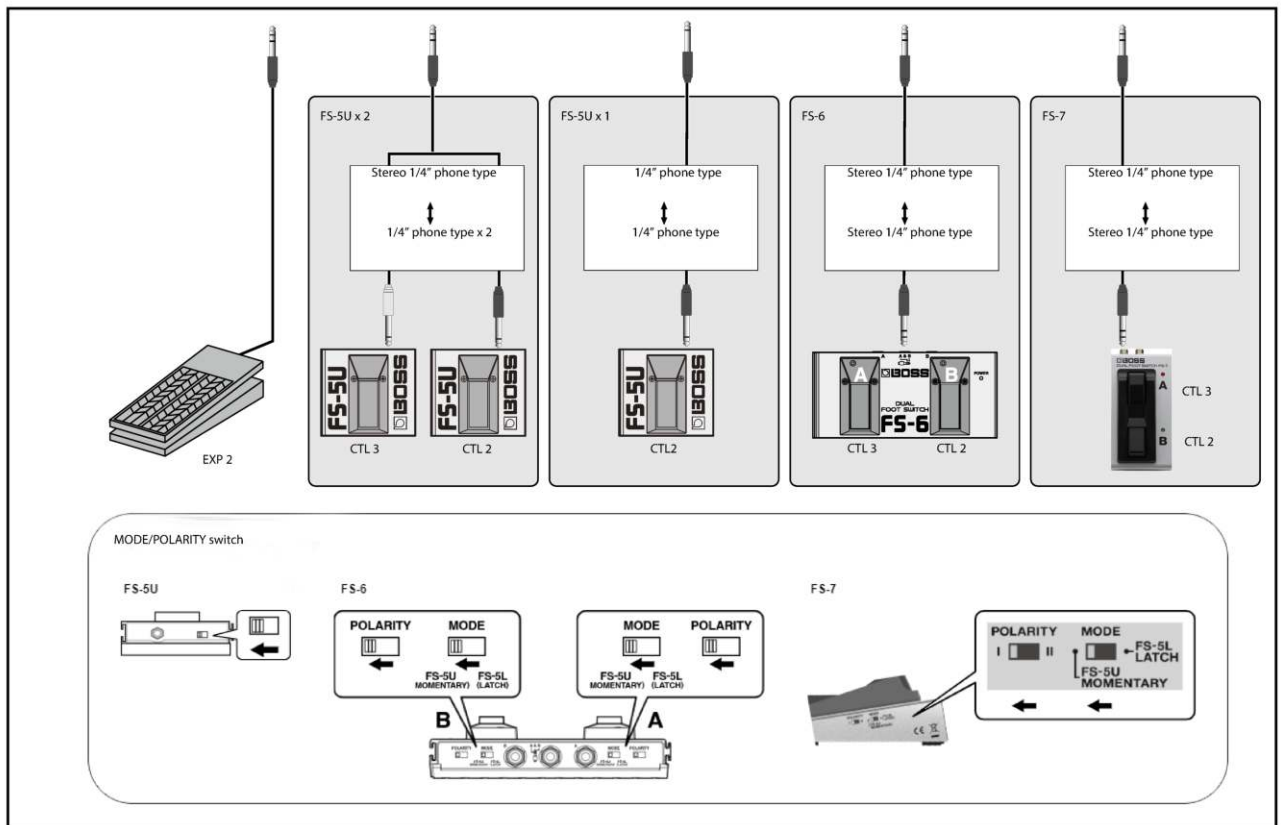

Looper

You can record what you play (up to 38 seconds in mono, and up to 19 seconds in stereo) and make the unit play back the recorded section over and over, as a loop. You can also layer additional performances with the recording as it plays back (overdubbing).

This lets you create real-time backing performances on the fly.

1 The looper turns on when you press both the [▲] switch and the [CTL1] (C1) switch at the same time.

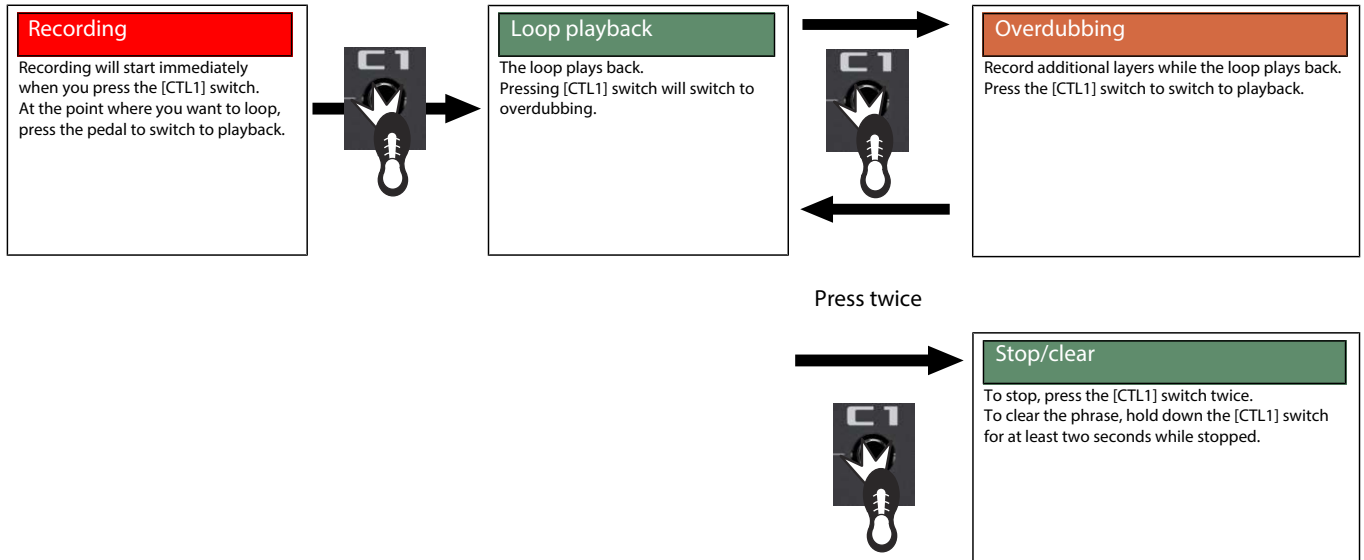

2 The looper turns off when you press both the [▲] switch and the [CTL1] (C1) switch again at the same time.

* The CTL1 (C1) settings stored in memory are ignored when the looper is on.

Loop playback level setting

If you set the playback level at 100 (default value), the volume of the performance and that of the loop playback will be identical.

If you set the playback level to a value lower than 100, the volume of the playback will be lower than that of the performance.

As a result, the sound of the performance won't get buried by the loop playback sound, even if you record a multiple number of times.

1 Press the [MENU] button.

2 Press the [▼][▲] buttons to move the cursor to the "LOOP SETTING" row.

3 Press the [2] knob.

LOOP SETTING	
	VALUE
LOOP MODE	MONO
LOOP REC ACTION	REC->PLAY->DUB
LOOP LEVEL	100

[1]:SELECT [3]:VALUE

[CTL1] (C1) switch color

The switches light up in the following colors when you assign the looper function to a footswitch on this unit.

Color	Status
Red	Recording
Orange	Overdubbing
Green	Playback
Green (blink)	Stopped (phrase exists)
Unlit	Stopped (no phrase)

MEMO

When COLOR MODE is set to a value other than "FULL", the switches light up as follows.

Color	Status
Red	Recording
Yellow	Overdubbing
Blue	Playback
Blue (blink)	Stopped (phrase exists)
Unlit	Stopped (no phrase)

Main specifications

Sampling Frequency	48 kHz
AD Conversion	24 bits + AF method * AF method (Adaptive Focus method) This is a proprietary method from Roland & BOSS that vastly improves the signal-to-noise (SN) ratio of the AD and DA converters.
DA Conversion	32 bits
Processing	32-bit floating point
Effects	135 types
Memories	99 (User) + 99 (Preset)
Phrase Loop	38 sec. (MONO) 19 sec. (STEREO)
Tuner Internal Detection	±0.1 cent
Nominal Input Level	INPUT: -10 dBu
Maximum Input Level	INPUT: +7 dBu
Input Impedance	INPUT: 1 M ohm
Nominal Output Level	OUTPUT (L/MONO, R): -10 dBu PHONES: -10 dBu
Output Impedance	OUTPUT (L/MONO, R): 1 k ohm PHONES: 44 ohms
Recommended Load Impedance	OUTPUT (L/MONO, R): 10 k ohms or greater PHONES: 44 ohms or greater
Controls	▼ switch, ▲ switch, CTL1 (C1) switch, EXP1 switch, v button, ^ button, MENU button, EXIT button, ENTER button, 1-3 knobs, EXP1 pedal, FX1/COMP button, OD/DS button, AMP/CAB button, FX2/EQ button, FX3/MOD button, DELAY button, REVERB button, EDIT button, PEDAL FX button
Display	Color Graphic LCD (320 x 240 dots)
Connectors	INPUT jack, OUTPUT (L/MONO, R) jacks: 1/4-inch phone type PHONES jack: Miniature phone type CTL2,3/EXP2 jack: 1/4-inch TRS phone type USB COMPUTER port: USB Type-C® DC IN jack
Power Supply	Alkaline battery (AA, LR6) x 4 USB BUS Power AC adaptor (PSA-S series: sold separately)
Current Draw	250 mA (AC adaptor/Battery) 400 mA (USB)
Expected battery life under continuous use	Alkaline: Approx. 5 hours * These figures will vary depending on the actual conditions of use.
Dimensions	307 (W) x 149 (D) x 56 (H) mm 12-1/8 (W) x 5-7/8 (D) x 2-1/4 (H) inches 307 (W) x 149 (D) x 73 (H) mm (maximum height) 12-1/8 (W) x 5-7/8 (D) x 2-7/8 (H) inches (maximum height)
Weight	1.2 kg 2 lbs 11 oz
Accessories	STARTUP GUIDE Alkaline battery (AA, LR6) x 4 Leaflet "Read Me First"

Options (sold separately)	AC adaptor: PSA-S series Footswitch: FS-5U, FS-5L, FS-6, FS-7 Expression Pedal: EV-30, FV-500L, FV-500H, Roland EV-5 Wireless MIDI Expression Pedal: EV-1-WL Wireless Foot Switch: FS-1-WL Carrying Bag: CB-BM-S
----------------------------------	---

* 0dBu=0.775Vrms

* This document explains the specifications of the product at the time that the document was issued. For the latest information, refer to the Roland website.

GX-1B
Reference Manual
01
Roland Corporation

© 2026 Roland Corporation