



 **KIRSTEIN.de**
We love music!



excellent sound

- Sauerstofffreies Kupfer
- Hochdichter Kupferschild
- Hochflexibler und robuster Außenmantel
- Handgelötet
- Säure- und ölfest
- Spannzangen und Zugentlastung
- Niedrige Leiterkapazität
- 3 Jahre Garantie
- Oxygen free copper
- High density copper shield
- Highly flexible and durable
- Soldered by hand
- Acid and oil proof
- Chuck type strain relief
- Low capacitance
- 3 years warranty



FR

Cet appareil
se recycle

À DÉPOSER
EN MAGASIN

À DÉPOSER
EN DÉCHÈTERIE



OU



FR



Points de collecte sur www.quefairedemesdechets.fr
Privilégiez la réparation ou le don de votre appareil !

CXN100

Manual Generated: 29/09/2025 - 13:54

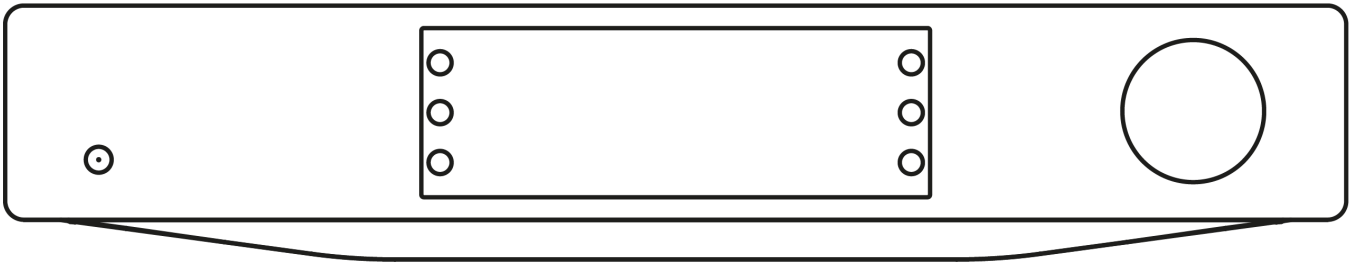

Table of Contents

CXN100	3
Introduction	3
What's included with the CXN100?	4
Front panel controls	5
Display	6
Rear panel connections	8
Remote Control	10
Getting connected	11
Connecting to WiFi	15
StreamMagic app - Setup	17
Google Home / Chromecast built-in	18
Internet radio	19
Bluetooth	20
AirPlay	21
Built-in streaming services	22
USB Audio	24
USB Media	27
Streaming your local digital music collection	28
MQA (Master Quality Authenticated)	29
Settings	30
Info screen	32
Technical specifications	33
Source quality matrix	35
Troubleshooting	36
Frequently asked questions	38

CXN100

Last updated: June 12, 2025 08:51. Revision #14352



Users Manual

Introduction

Last updated: November 29, 2023 09:17. Revision #11481

This guide is designed to make installing and using this product as easy as possible. Information in this document has been carefully checked for accuracy at the time of publishing; however, Cambridge Audio's policy is one of continuous improvement, therefore design and specifications are subject to change without prior notice.

This document contains proprietary information protected by copyright. All rights are reserved. No part of this manual may be reproduced by any mechanical, electronic or other means, in any form, without prior written permission of the manufacturer. All trademarks and registered trademarks are the property of their respective owners.

The Bluetooth® word mark and logos are registered trademarks owned by the Bluetooth SIG, Inc. and any use of such marks by Audio Partnership Plc is under license. Other trademarks and trade names are those of their respective owners.

Qualcomm is a trademark of Qualcomm Incorporated, registered in the United States and other countries, used with permission.

aptX is a trademark of Qualcomm Technologies International, Ltd., registered in the United States and other countries, used with permission. Qualcomm aptX is a product of Qualcomm Technologies International, Ltd.

StreamMagic is a trademark of Audio Partnership Plc and is registered in the European Community and other countries.

This product contains software licensed under version 2 of the GNU Public License and version 2.1 of the GNU Lesser Public License. The source code for this software is available from: <http://gpl.stream-magic.com/>

This product includes technology owned by Microsoft Corporation and under a licence from Microsoft Licensing GP. Use or distribution of such technology outside of this product is prohibited without a license from Microsoft Corporation and/or Microsoft Licensing, GP as applicable.

The Spotify software is subject to third party licenses found here: www.spotify.com/connect/third-party-licenses.

This product support AirPlay 2 and requires iOS 11.4 or later.

Apple and AirPlay are trademarks of Apple Inc., registered in the U.S. and other countries.

Use of the Works with Apple badge means that an accessory has been designed to work specifically with the technology identified in the badge and has been certified by the developer to meet Apple performance standards.

Android, Google Play and the Chromecast built-in logo are trademarks of Google Inc.

TIDAL and TIDAL logo are registered trademark of Aspiro AB in the European Union and other countries.

MQA and the Sound Wave Device are registered trade marks of MQA Limited © 2016.

© Copyright Cambridge Audio Ltd

For upcoming news on future products, software updates and exclusive offers, make sure you register your product at <https://www.cambridgeaudio.com/register>

What's included with the CXN100?

Last updated: February 1, 2024 01:32. Revision #11674

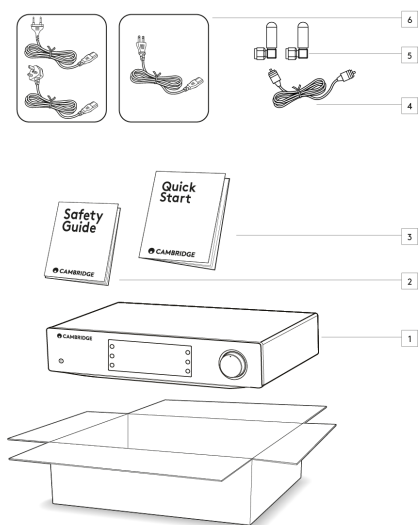

Inside the box of your CXN100 you will receive:

1. CXN100 Network Player
2. Safety Guide
3. Quick Start Guide
4. Control Bus Cable
5. 2x Wi-Fi/Bluetooth Antennas
6. Regional Power Cable

Front panel controls

Last updated: February 1, 2024 01:32. Revision #11675

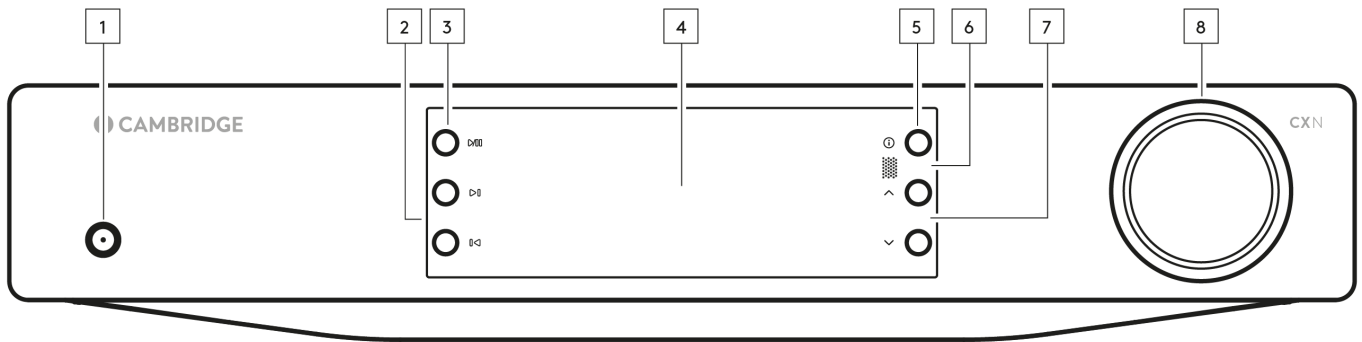

1. Standby/On

Switches the unit between Standby Mode (indicated by dim power LED) and On (indicated by bright power LED).

2. Skip

Skip to next track during playback.

3. Play/Pause

Play or Pause current track.

4. Display

5. Info

During playback, pressing this button will cycle through the different 'Now Playing' screens. Press and hold to display the product info, as well as options for updating the firmware, network setup mode and factory reset.

6. Infrared sensor

IR sensor that receives IR commands from the compatible CX series 2 remote control.

Note: The CXN100 does not have its own remote control and does not come with one included.

7. Source Selector

Scroll through sources enabled in the StreamMagic app.

8. Volume Control

When Pre-amp mode is enabled this will control volume via the analogue outputs.

Display

Last updated: January 18, 2024 09:46. Revision #14076

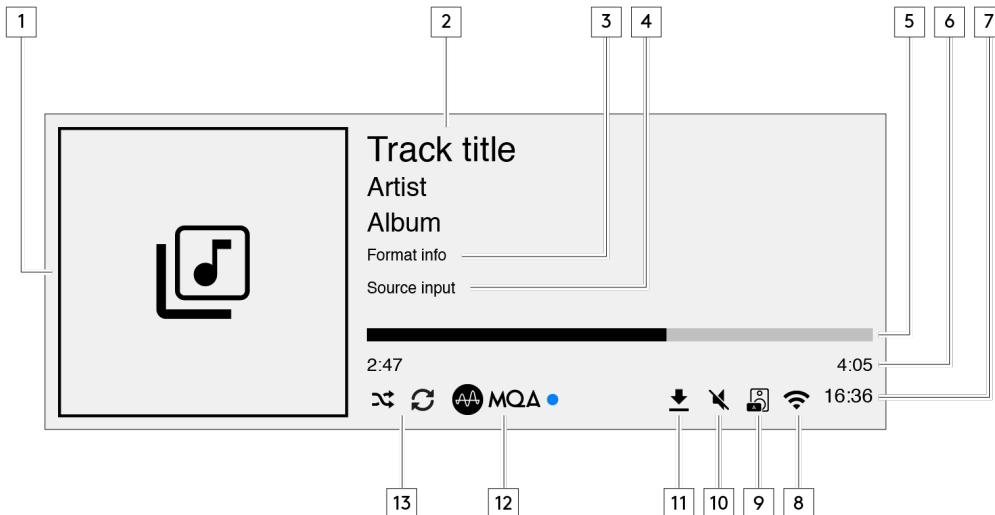

1. Album/Source artwork

Displays the album artwork. Alternatively, if no artwork is available this will display the source input icon.

2. Track title, artist and album

For Internet Radio, this will display the radio station name and the current playback.

3. Format info

Displays the streaming sample rate. For Internet Radio, this will display the bitrate the station is streaming.

4. Source input

Displays the currently selected source input.

5. Progress bar

When available, this will display the current track progression during playback.

6. Track time

When available, this will display the elapsed track time during playback.

7. Clock

8. Network connection

Displays the current network connection.



Wireless network connection



Wireless connection with no internet access



Wired network connection



Wired connection with no internet access



No network connection

9. Speaker output

Displays the currently selected speaker output on relevant network streamers.

10. Mute volume

Displays when the network streamer is muted.

11. Firmware update

This indicates when new firmware is available. Press the 'Info' button on the front panel or use the StreamMagic app to update the network streamer's firmware.

12. MQA indicator

See the [MQA](#) section for more details.

13. Shuffle, Repeat and Repeat +1

Rear panel connections

Last updated: February 1, 2024 01:33. Revision #11677

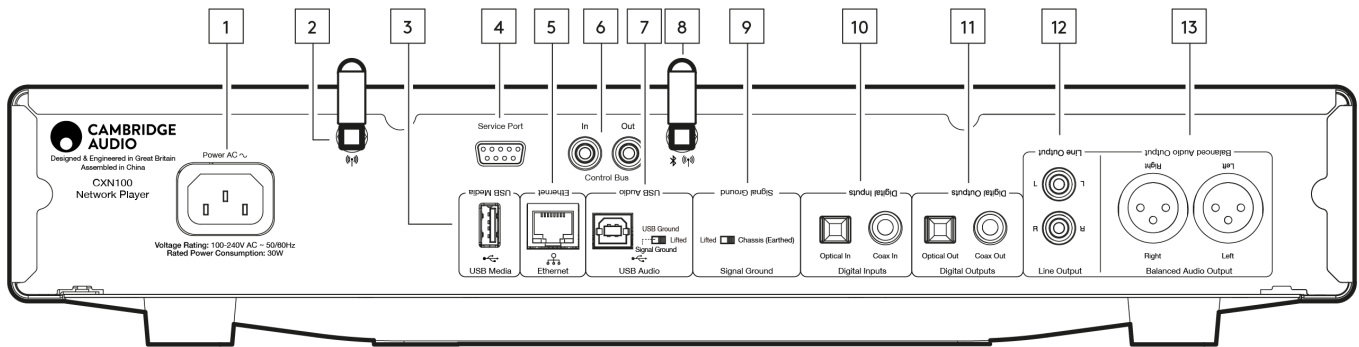

1. AC Power socket

Once you have completed all connections to the amplifier, plug the AC power cable into an appropriate mains socket then switch on.

2. WiFi Antenna

Ensure antenna is connected securely before use.

3. USB Media

For connecting local media storage. Note that the USB ports are not intended for connection to mobile devices; no functionality, charging or otherwise is supported.

4. Service Port

For servicing use only.

Note: Connecting any other device here may result in damage.

5. Ethernet

Use to connect the CXN100 directly to a network router. Use a wired connection for seamless playback of high-resolution 352.8kHz, 384kHz, and DSD 256.

6. Control Bus

RCA sockets used to send and receive power and volume commands from other connected CX Series products. For more information on the Control Bus, see Control Bus section [here](#).

7. USB Audio In

A USB B type socket to enable connection to PC and Mac computers.

Note: For Class 2 USB audio, Windows-based PCs require a Cambridge Audio USB driver to be installed before connection. You can find the latest USB driver [here](#).

USB Ground Switch

Note: The ground switch position should be set to 1 as default. Use another position if a humming noise occurs.

Position 1 - Normal/default position. The main unit audio ground is lifted from chassis earth.

Position 2 - USB Audio ground is lifted from the main unit audio ground, which is also lifted from chassis earth. This may be useful to reduce hum and noise that can occur with some USB Audio setups.

8. WiFi/Bluetooth Antenna

Ensure antenna is connected securely before use. Bluetooth functionality won't be possible if this antenna is not connected.

9. Chassis Ground Switch

Position 1 - Normal/default position. The main unit audio ground is lifted from chassis earth.

Position 2 - Main unit audio ground is connected directly to chassis ground. For some setups, this can reduce hum or noise when certain TVs, Turntables, and other equipment are connected to the CXN100 unit.

10. Digital Inputs (Coax and Optical)

TOSLINK and S/P DIF coaxial digital inputs.

Coaxial – Use a high quality 75 ohm digital RCA Phono interconnect cable (This is different from an analogue audio phono interconnect). This input is suitable for 16-24 bit content up to 192kHz.

TOSLINK Optical – Use a high quality TOSLINK fibre optic interconnect cable designed specifically for audio use. This input is suitable for 16-24 bit content up to 96kHz (TOSLINK is not recommended at 192kHz sampling rates).

Note: If a digital input is connected to a TV, you can enable TV mode in the sources settings of the StreamMagic app. This mode minimises lip-sync delays on the audio path by bypassing MQA decoding and also reduces the chance of dropouts and glitches from some TVs.

11. Digital Outputs

TOSLINK and S/P DIF coaxial digital outputs.

12. Line Output

Line Output (fixed or variable) used to provide a signal to another amplifier or a recording device.

13. Balanced Audio Output

For use with balanced XLR connections. The balanced connection is the higher quality option and can reject noise and interference in the cable when used with other equipment that supports this function.

Note: XLR connectors should be wired as follows: Pin 1: Ground, Pin 2: Hot (in-phase) and Pin 3: Cold (phase-inverted).

Remote Control

Last updated: March 6, 2024 03:22. Revision #11877

Note: The CXN100 does not have its own remote control and does not come with one included. The device can be controlled via the StreamMagic app. If you wish to use a remote control with your device, the CX series 2 remote control is compatible with the CXN100.

1. Standby/On

Switches the CXN100 between On and Standby mode.

2. Brightness

Alters the brightness of the CXN100 display. There are two brightness levels and an option to switch off the backlight.

Note: When the brightness is switched to 'off', selecting any of the functions will briefly switch on the lights to show the change.

3. Mute

Press to mute or un-mute the audio. This can only be used with Pre-amp mode enabled.

4. Random

Play random track within queue.

5. Repeat

Repeat all tracks in queue.

6. Volume

Volume level adjust. This can only be used with Pre-amp mode enabled when connected via the analogue outputs.

7. Info

Tapping will toggle between display information. Holding will display the 'info' screen.

8. Skip

Skips between previous and next tracks.

9. Enter

Enter or select.

10. Source Selector

Scroll through sources enabled in the StreamMagic app.

11. Play/Pause

Play or Pause current track.

12. Presets

Recalls stored 1 - 8 presets.

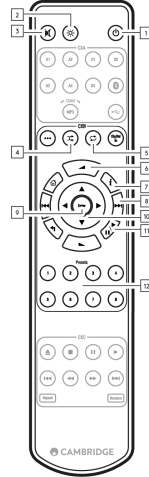

If the remote control will not function, please check that the batteries have not expired, and that there is nothing blocking the front panel IR sensor.

Getting connected

Last updated: February 1, 2024 01:33. Revision #11679

Basic Analogue Connections

Important Note: Switch the power off before making any connections.

There are two analogue connection options for the CXN100.

1. Line Output Connection (RCA)

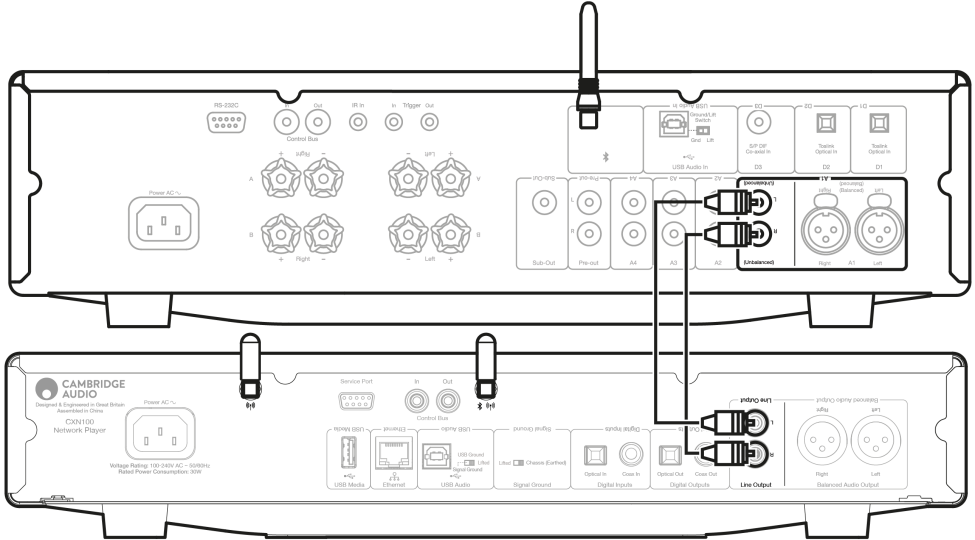

2. Balanced Audio Connection (XLR)

The balanced connection is the higher quality option and can reject noise and interference in the cable when used with other equipment that supports this function.

Note: XLR connectors should be wired as follows: Pin 1: Ground, Pin 2: Hot (in-phase) and Pin 3: Cold (phase-inverted).

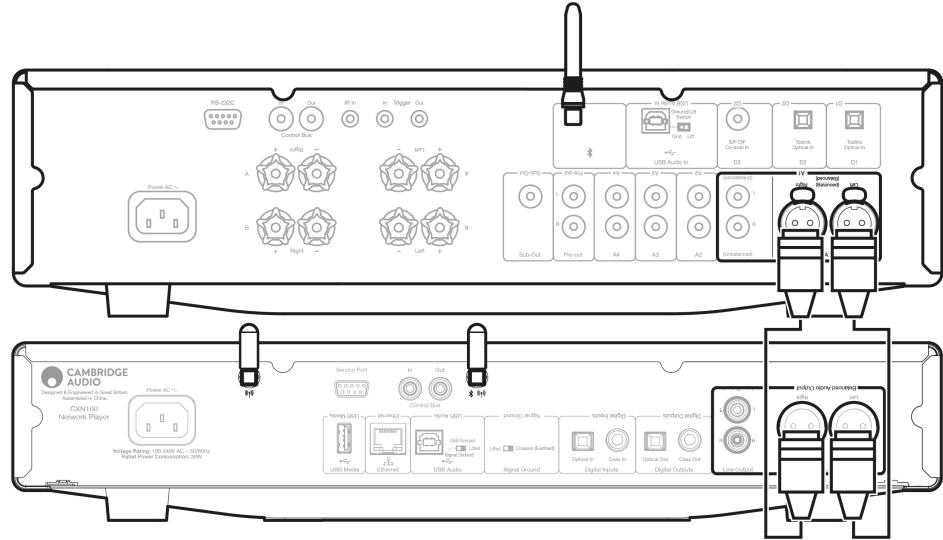

Basic Digital Connections

There are two digital connection options for the CXN100.

Note: If using either of the digital outputs of the CXN100, the digital signal will bypass the DAC in CXN100 and will instead be processed by the unit connected to the digital output, E.g., CXA81

1. Digital Coaxial Output

Digital Coaxial connections are commonly used with CD players and amplifiers and is recommended for use as it has higher bandwidth.

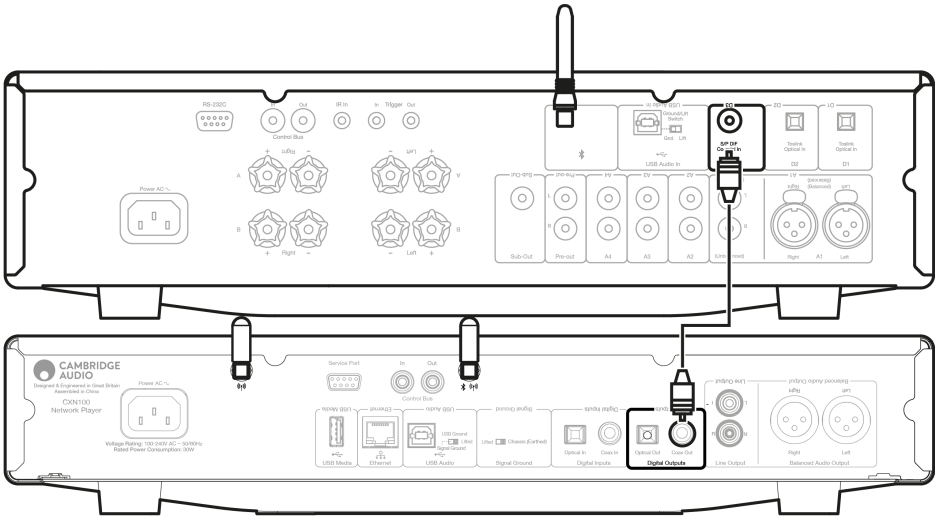

2. TOSLINK Optical Output

Whilst having lower bandwidth, TOSLINK Optical connections are commonly found on televisions, DVD players and A/V units.

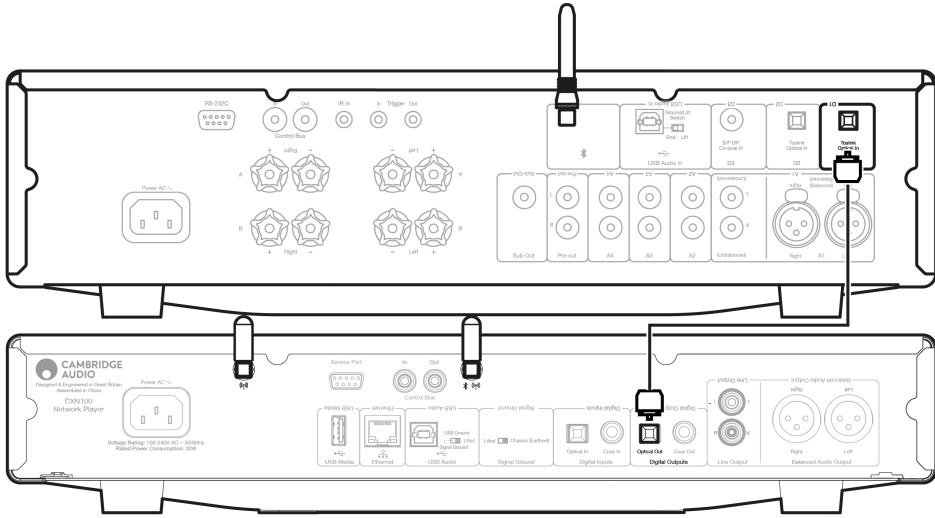

Control Bus

The Control Bus lets you control your other CX series units. See the following diagrams when connecting the CXN100 using the provided Control Bus cable.

Another added feature with this Control Bus is the use of the StreamMagic app. You can use the StreamMagic app to control other CX series units via the CXN100.

CXN100 with CXA (via StreamMagic app)

When using the app to turn the CXN100 on/off, this will also turn the CXA on/off. The app can also be used to control the volume of the CXA. Connect the CXN100 Control Bus Out to CXA Control Bus In.

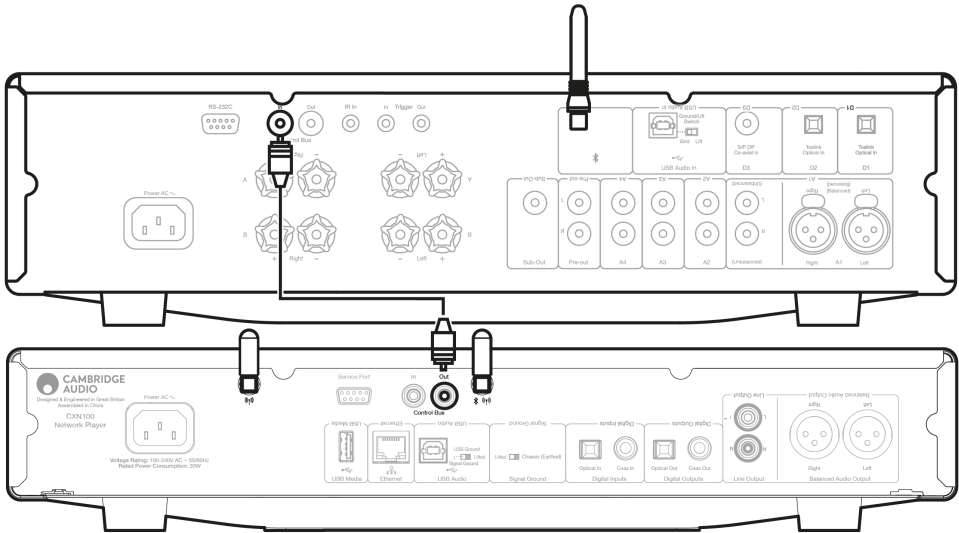

CXA with CXN100

Note: Without using the StreamMagic app to control the CXA.

When turning the CXA on/off, this will also turn the CXN100 on/off. Connect the CXA Control Bus Out to CXN100 Control Bus In.

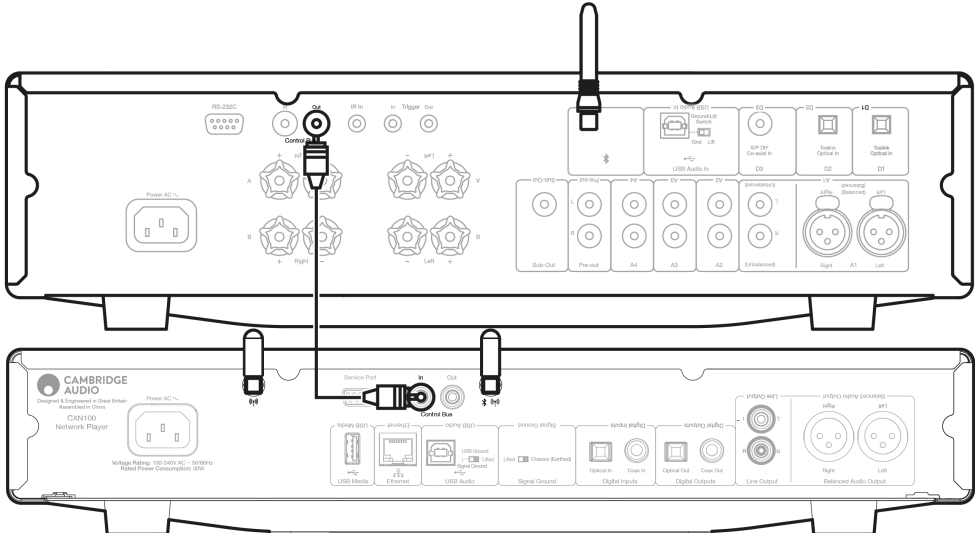

CXA with CXN100 and CXC

When turning the CXN on/off, this will turn the CXA and CXC on/off.

With all three CX devices, connect the CXN100 Control Bus out to CXA Control Bus in. Then connect the CXA Control Bus out to CXC Control Bus in.

Note: Do **NOT** loop back from the CXC Control Bus out to the CXN100 Control Bus in.

Control Bus will also need to be enabled and set to Amplifier within the device settings in the StreamMagic app once the app has been connected to the CXN100.

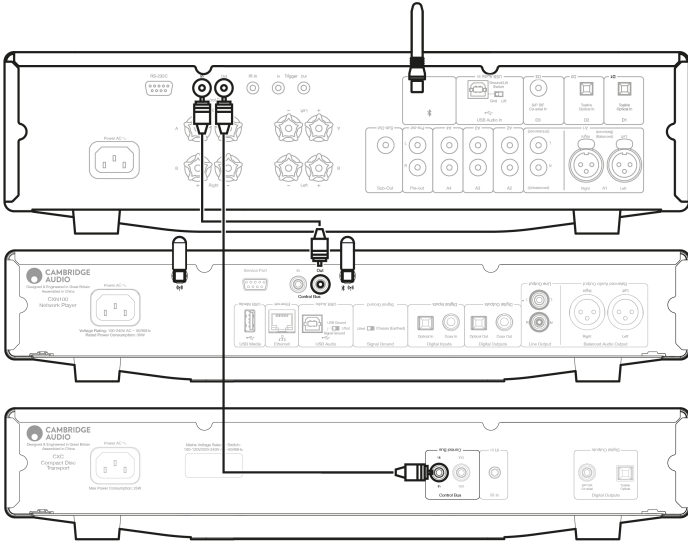

Note: If a device with APD enabled automatically switches off after the selected period of inactivity, this will also switch off the other connected devices.

Connecting to WiFi

Last updated: March 5, 2024 03:07. Revision #11876

Important Note: It is vitally important that your Network Player remains connected to an internet network as often as possible, either via Wi-Fi or Ethernet. This will ensure that the unit is regularly updated to meet essential security protocols, third party compatibility and the latest software requirements.

Failure to maintain your device with regular firmware updates as provided by Cambridge Audio will void the product warranty and is likely to cause major issues to the unit in time. Please ensure that your unit is updated to the most current firmware version.

Note: Your player is not compatible with captive portal networks. Where possible, avoid the use of powerline adapters and Wi-Fi signal boosters/extenders, as these can disrupt the reliability of the network connection.

Connecting to a Wired Network

1. Connect a network cable (Category 5/5E straight-through Ethernet cable) between your device and your router.
2. Your device will now automatically connect to the network.

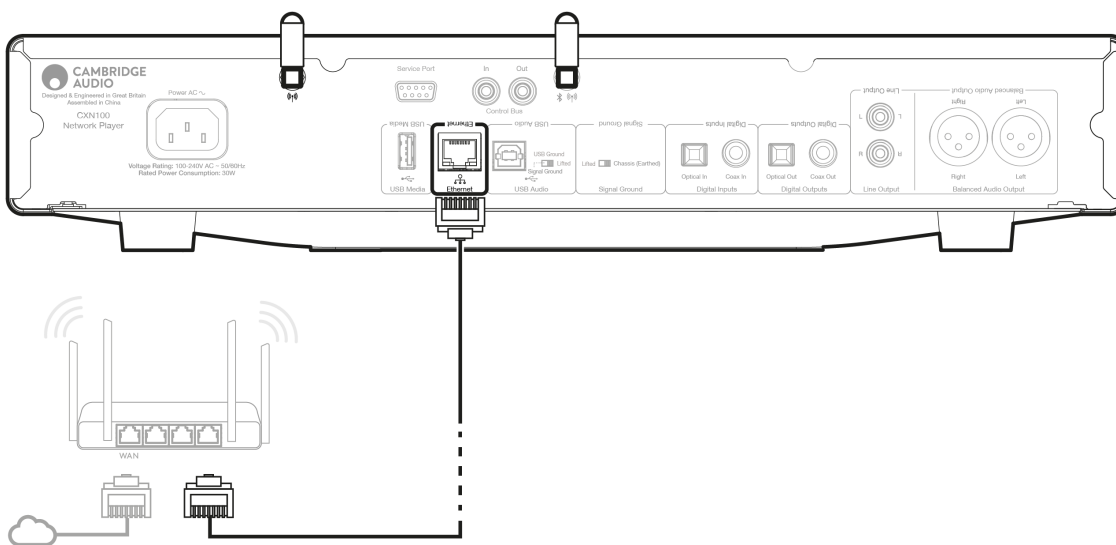

Connecting to a wireless network

iOS:

1. Connect both of the supplied Wi-Fi antennas to the rear of the unit, and ensure that it's in range of your wireless router. Then power on your unit.

Note: If you are setting up your device for the first time or after a factory reset, you will first need to follow the on screen instructions to select your preferred language after powering on your unit.

2. Go to the Wi-Fi settings on your iOS device and under 'SETUP NEW AIRPLAY SPEAKER' select the name of your Network Player.

Note: Some iOS devices won't show an option for 'AirPlay Speaker'. In this instance still select the name of your Network Player.

3. Once connected, complete unit setup by downloading and installing the [StreamMagic app](#) from the [Apple App](#) store.

Android:

1. Connect both of the supplied Wi-Fi antennas to the rear of the unit, and ensure that it's in range of your wireless router. Then power on your unit.

Note: If you are setting up your device for the first time or after a factory reset, you will first need to follow the on screen instructions to select your preferred language after powering on your unit.

2. Download and install the [StreamMagic app](#) from the [Google Play](#) store.

3. Open the StreamMagic app and select 'Connect'.
4. Under Choose a device select 'Set up a new device' and then select the name of your Network Player.
5. Select 'Wireless Connection' and then 'Continue'.
6. Your Android device will now show all available Wi-Fi devices in range. Select the name of your Network Player.
7. Once connected, you will be prompted to enter your Wi-Fi network password. Enter the password and select 'Continue'.
8. Your device will now connect to your Wi-Fi network, this may take up to a minute.
9. Once connected, complete the initial setup of your unit within the StreamMagic app.

StreamMagic app - Setup

Last updated: January 24, 2024 02:15. Revision #11506

Your player is network connected, not only can you listen to devices connected to the inputs on the product but you can also stream music from many different sources both on your home network and from the internet.

To set up your player, please first download the StreamMagic app from the Apple app store or Google Play store.



Set up

1. Switch on your player and follow the on screen instructions to select your preferred language.
2. Open the StreamMagic app and follow the instructions provided to complete setting up your player on your network. This process will also apply any new updates that may be pending.

Note: During the set up process you will be asked to give your player a name, please make sure this is unique to your player. This will make it easier to find when using streaming and smart home services.

Once your player is connected to your home network you'll have full control of your sources, including internet radio, streaming services, network and USB drives and more.

For more information on our StreamMagic app, please visit: <https://www.cambridgeaudio.com/gbr/en/products/streammagic>

Important Note: It is vitally important that your player remains connected to a Wi-Fi network as often as possible. This will ensure that the unit is regularly updated to meet essential security protocols, third party compatibility and the latest software requirements.

Failure to maintain your device with regular firmware updates as provided by Cambridge Audio will void the product warranty and is likely to cause major issues to the unit in time. Please ensure that your unit is updated to the most current firmware version. Information on the latest firmware version for your player can be found here.

Note: Your player is not compatible with captive portal networks. Where possible, avoid the use of powerline adapters and Wi-Fi signal boosters/extenders, as these can disrupt the reliability of the network connection.

Google Home / Chromecast built-in

Last updated: January 18, 2024 02:13. Revision #11491

Your player is network connected, not only can you listen to devices connected to the inputs on the product but you can also stream music from many different sources both on your home network and from the internet.

Your player features Chromecast built-in and can be incorporated in to your Google Home. To set up your player, download the Google Home app on your smart phone or tablet.



With Chromecast built into your player, your phone becomes your remote. Simply tap the Cast button from apps you already know and love to stream music, podcasts and playlists from your phone, tablet or laptop to your player.

Chromecast built-in

Your phone is your remote

- Simply tap the Cast button from apps you already know and love. No new logins or downloads required.
- Use your phone to search, play, pause and turn up the volume from anywhere in the home.
- While you're streaming, you can keep using your phone for other things - scroll through social media, send a text, and even accept calls.
- Enjoy music throughout your house when you use multi-room casting with Chromecast-enabled speakers.
- Just say "Hey Google" to cast to your player

Unlimited entertainment, all on your schedule

- Works with hundreds of apps and new apps are being added all the time.
- Choose from millions of songs from popular music services like Pandora, Spotify, and Youtube Music.

Note: When first setting up your Player via the StreamMagic app or after a factory reset, please ensure that you accept Google's terms and conditions when prompted to enable Chromecast functionality.

Android, Google Play and the Chromecast built-in logo are trademarks of Google Inc.

Full Chromecast built-in features may not be available in some territories.

Internet radio

Last updated: October 3, 2024 09:36. Revision #14089

You can browse and play a wide variety of Internet Radio stations in the StreamMagic app Radio tab. You can also assign up to 99 of your favourite Internet Radio stations and other media as presets on your player, which can then be recalled using the StreamMagic app. A limited amount of presets can be recalled via the remote control if your player includes one.

You can search and assign a preset via the StreamMagic app:

1. Within the StreamMagic app navigate to the **Radio** tab.
2. Use the **Search for Radio** search tab at the top of the page or enter a Custom URL link by selecting URL.
3. Once you have located the station you wish to store, select and you will be prompted with the option to **Play now** or **Add to presets**.
4. Add station to the desired preset for your player between 1-99.
5. You will then receive confirmation that the station is saved to the chosen preset.

Note: Please ensure that the custom URL stream is one of the following supported file types: ALAC, WAV, FLAC, AIFF, DSD (x256), WMA, MP3, AAC, HE AAC AAC+, OGG Vorbis.

To remove a preset (iOS):

1. Within the StreamMagic app navigate to the **Home** tab.
2. Scroll to the bottom of the page where you find your player's **Presets**, and select **EDIT**.
3. To remove a station from preset, tap the red circle icon and then press **Delete**.

To remove a preset (Android):

1. Within the StreamMagic app navigate to the **Home** tab.
2. Scroll to the bottom of the page where you find your players **Presets**, and select **EDIT**.
3. Tap on the station you wish to remove.

Note: You may also assign a preset using a remote control if your player includes one, by pressing and holding a number on the remote whilst a station is playing.

Bluetooth

Last updated: October 3, 2024 09:37. Revision #14088

The Bluetooth source allows your player to receive wireless Bluetooth audio from most phones, tablets and laptops.

Pairing

To begin streaming high-quality music from your chosen media source it will first need to be paired with your player.

1. Within the StreamMagic App navigate to the Home tab.
2. Use the "Edit" option of the source to add the Bluetooth source.
3. Return to the Home tab and select the Bluetooth source.
4. Open your mobile device or laptop's Bluetooth settings.
5. Select your player from the list of available devices.
6. Your device should now connect to your player.

Once paired you should be able to connect to your player at any time by selecting the Bluetooth source on your player and then choosing your player from the list of previously connected devices.

Note:

Your Bluetooth device can only be connected to your player while the Bluetooth source is selected.

AirPlay

Last updated: October 3, 2024 09:38. Revision #14087

AirPlay is an Apple technology designed to control home audio systems and speakers in any room — with a tap or by just asking Siri — right from iPhone, iPad, HomePod, or Apple TV. Play a song in the living room and kitchen at the same time or adjust the volume in any room, all in sync.

After installing your player, add it to the Apple Home app with a few simple steps using your iPhone or iPad

How to use AirPlay from iPhone or iPad

1. Ensure your player is connected to your network.
2. Open the app that you want to AirPlay from.

3. Tap  or .

4. Select your player as your AirPlay device.

How to use AirPlay from Control Center

To switch the audio on your device from Control Center:

Swipe down from the top right side of the screen on your device to open Control Center.

Touch and hold  in the upper-right corner, then select your player.

This product supports AirPlay 2 and requires iOS 11.4 or later.

Apple and AirPlay are trademarks of Apple Inc., registered in the U.S. and other countries.

Use of the Works with Apple badge means that an accessory has been designed to work specifically with the technology identified in the badge and has been certified by the developer to meet Apple performance standards.

Built-in streaming services

Last updated: October 3, 2024 09:34. Revision #14086

Your player has the following built-in streaming services:

- Spotify Connect
- TIDAL
- Qobuz
- Deezer

Note: It is essential that the device you are streaming from (smartphone, tablet, computer, etc.) is on the same Wi-Fi network as your player, to ensure that the units can communicate with each other.

Spotify Connect

Use your phone, tablet or computer as a remote control for Spotify.

Go to spotify.com/connect to learn more.

TIDAL (Connect)

1. Open the TIDAL app and choose the playlist, album, song, etc. that you wish to stream to your player.
2. Select the Sound Output devices icon within TIDAL and select your player from the list.
3. TIDAL Connect should now be streaming your chosen content to your player.

Go to tidal.com/connect to learn more

TIDAL (via StreamMagic)

1. Open the StreamMagic app and navigate to the Library tab, and then select TIDAL.

Note: Please ensure that you sign into your TIDAL account when prompted to do so. This will only be required on the first instance of use to link the account to the StreamMagic app.

2. Choose the playlist, album, song, etc. that you wish to stream to your player.
3. TIDAL should now be streaming your chosen content to your player.

Qobuz (via Google Cast)

1. Open the Qobuz app and choose the playlist, album, song, etc. that you wish to stream to your player.
2. Select the Google Cast icon within Qobuz and select your player from the Qobuz Connect list.
3. Qobuz should now be casting your chosen content to your player.

Qobuz (via StreamMagic)

1. Open the StreamMagic app and navigate to the Library tab, and then select Qobuz.

Note: Please ensure that you sign into your Qobuz account when prompted to do so. This will only be required on the first instance of use to link the account to the StreamMagic app.

2. Choose the playlist, album, song, etc. that you wish to stream to your player.
3. Qobuz should now be streaming your chosen content to your player.

Deezer (via Google Cast)

1. Open the Deezer app and choose the playlist, album, song, etc. that you wish to stream to your player.
2. Select the speaker icon within Deezer, then select 'Google Cast'. Select your player from the list.
3. Deezer should now be casting your chosen content to your player.

Deezer (via StreamMagic)*

1. Open the StreamMagic app and navigate to the Library tab, and then select Deezer.

Note: Please ensure that you sign into your Deezer account when prompted to do so. This will only be required on the first instance of use to link the account to the StreamMagic app.

2. Choose the playlist, album, song, etc. that you wish to stream to your player.

3. Deezer should now be streaming your chosen content to your player.

*Deezer is only available within the StreamMagic app when running firmware version 129-b-004 or later and StreamMagic app version 2.9.0 or later.

USB Audio

Last updated: May 14, 2024 03:06. Revision #12866

Important note: Before setting up your device for the first time, please make sure that the USB Audio connection is unplugged. USB Audio can be re-connected once any firmware updates are applied.

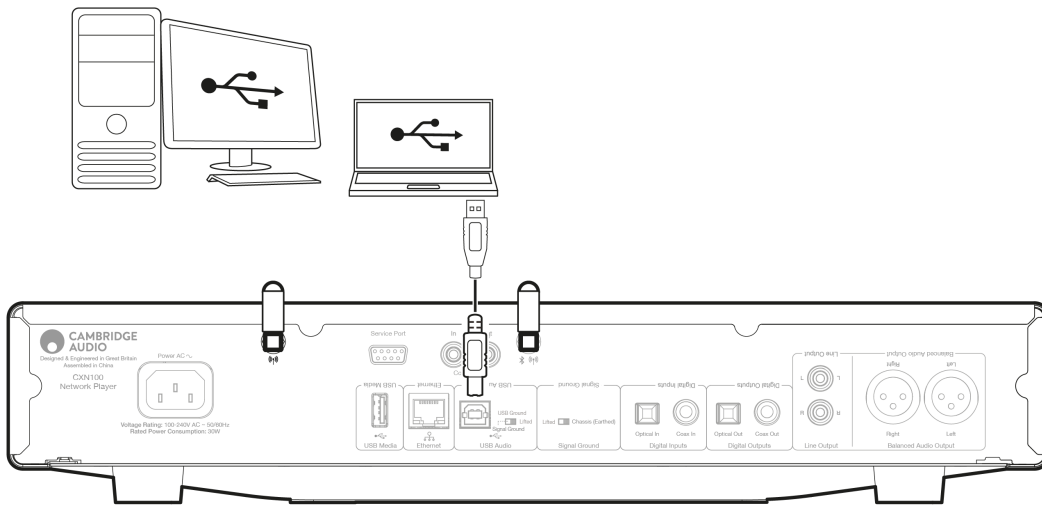

PC Setup

Note: Before connecting your PC to the Network Player, ensure you install the required Cambridge Audio Windows 2.0 USB driver on your PC. Please find information on the most recent USB Audio driver [here](#), and a link to download the latest driver [here](#).

1. Connect your device to your PC.

- After installing the correct driver, using a USB Audio cable (Type A to Type B), connect the USB Audio In on your device to a USB port on the PC.

2. Select the USB Audio source.

- This can be done using the source selector on the front of the device, or by going to the **Home** tab and then selecting USB Audio within the **Sources** section of the StreamMagic app.

3. Navigate to the **CA Control Panel** which should now be installed in your Windows taskbar. This will show any connected Cambridge Audio USB Audio device and current sample rate.

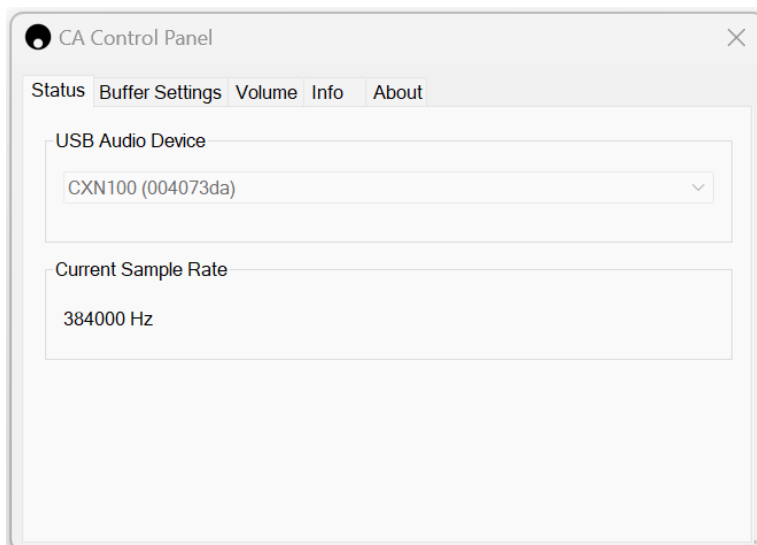

4. On your PC, navigate to **Settings > System > Sound**. Select your Network Player as your output device from the drop-down menu.

5. Within this same window under **Related Settings** on the right-hand side, select **Sound Control Panel**. Alternatively, scroll down and select **More Sound Settings**.

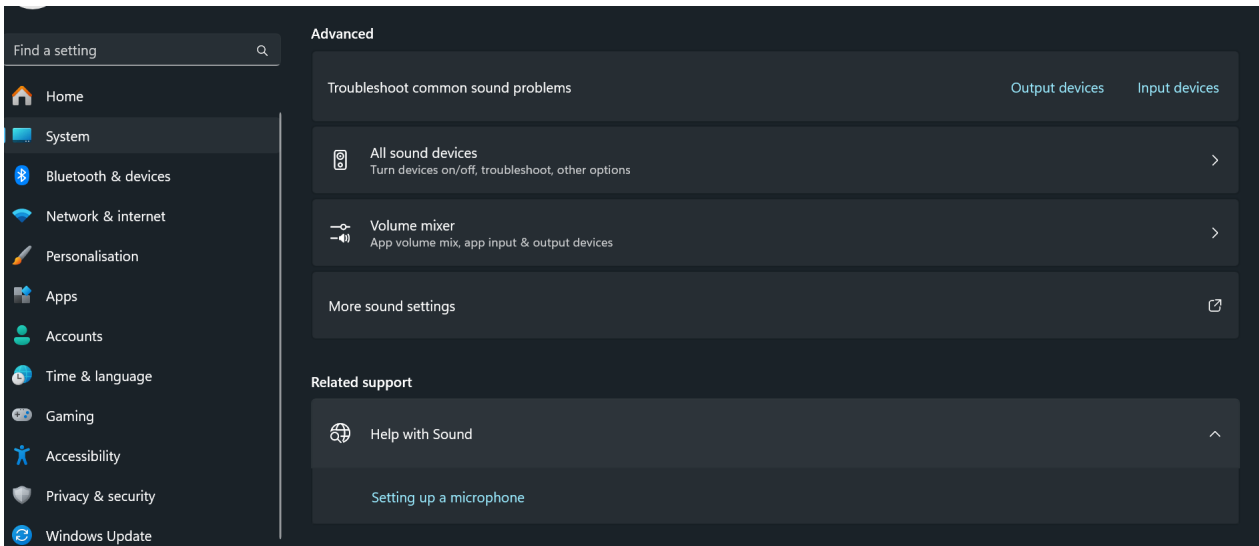

6. On the **Playback** tab, ensure that the device is the default output device, then select **Properties**.

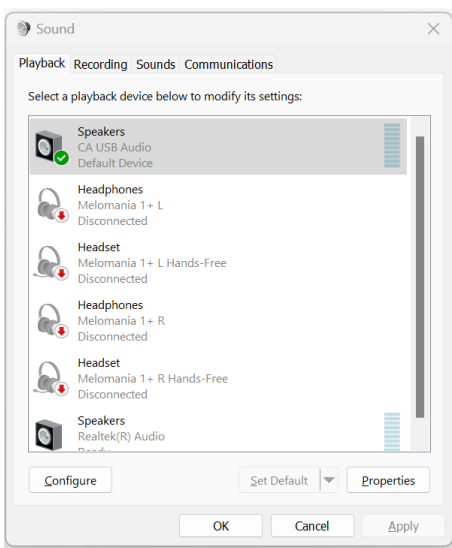

7. Within **Speaker Properties**, navigate to the **Advanced** tab. Select the desired bit depth and sample rate preference. (This step is optional.)

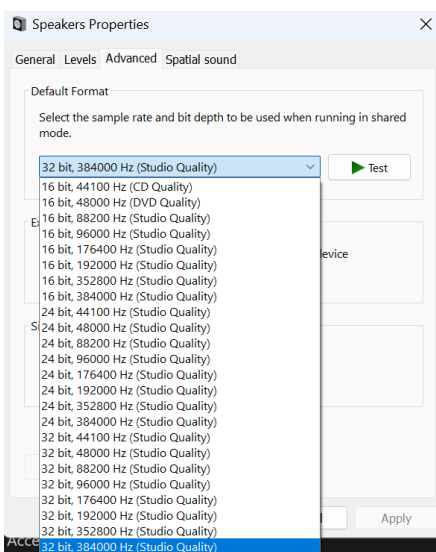

Note: Not all Windows versions support playback at sample rates greater than 384kHz. If you experience issues please set the default Windows playback format to 384kHz or lower, then restart your Network Player.

8. Your PC's output will now playback via your Network Player.

Mac Setup

Note: No extra drivers are required when using a Mac.

1. Connect your device to your Mac.

- Using a USB Audio cable (Type A to Type B), connect the USB Audio In on your device to a USB port on the Mac.

Note: If using a Mac without a USB Type A port, you may also use USB Type C (Thunderbolt 3) to USB Type B connection.

2. Select the USB Audio source.

- This can be done using the source selector on the front of the device, or by going to the **Home** tab and then selecting **USB Audio** within the Sources section of the StreamMagic app.

3. Within the **System Preferences** of the Mac, locate the **Sound** settings. Select your Network Player as the output sound device.

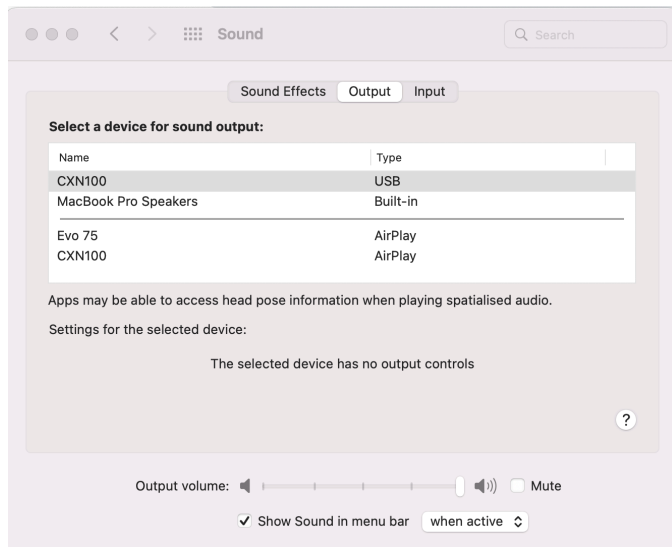

4. On the Mac navigate to **Applications > Utilities > Audio MIDI Setup**. Select the device as the output sound device on the left column, and then using the drop-down options select the desired bit depth and sample rate preference.

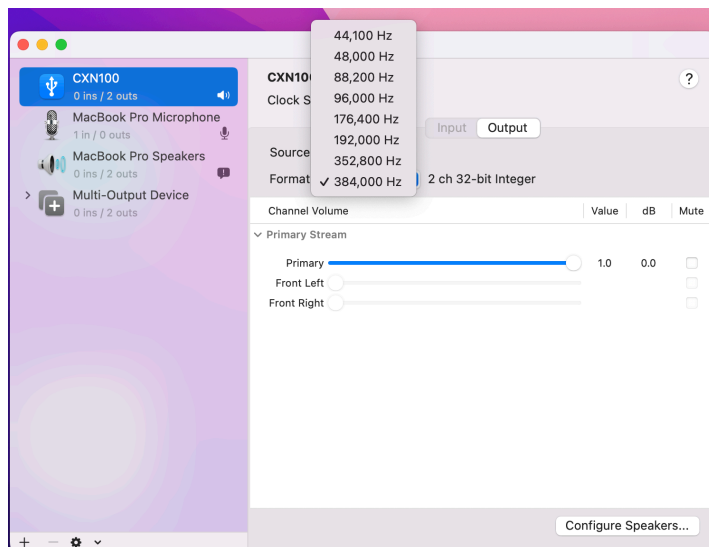

Note: This step is optional.

5. Your Mac's output will now playback via your Network Player.

USB Media

Last updated: October 3, 2024 09:39. Revision #14084

You may connect a USB SSD, USB HDD or flash drive to your player via the USB Media input located on the rear of the unit for playback. Once connected, the following formats are supported: ALAC, WAV, FLAC, AIFF, DSD, WMA, MP3, AAC, HE AAC, AAC+, OGG Vorbis

Note: your player will read large capacity hard drives connected to the USB input. However, some larger capacity drives will require you to use their own power supply.

Your player only supports USB hard drives which are formatted to FAT32, exFAT, NTFS and Ext4.

The primary function of your player is as a network music player. The USB ports are intended for convenient connection of USB thumb drives. As such, we cannot guarantee compatibility with all USB HDD's.

USB Media Playback (via StreamMagic app)

1. Connect a USB SSD, HDD or flash drive to rear panel USB Input.
2. Navigate to the Library tab of the StreamMagic app.
3. Under USB Drives, locate your USB Media device and open.
4. Upon selecting a track you will have the option to 'PLAY FROM HERE', 'PLAY TRACK NOW', 'PLAY TRACK NEXT' or 'QUEUE TRACK'.

Playback Options:

PLAY FROM HERE - Playback of album/folder will begin from this point onwards.

PLAY TRACK NOW - Selected track will playback immediately.

PLAY TRACK NEXT - Selected track will be added to queue and playback next.

QUEUE TRACK - Selected track will be added to playback queue.

Streaming your local digital music collection

Last updated: May 14, 2024 03:09. Revision #14083

Your player can play content from many different physical sources and this section will explain what you need to do to access and play your locally stored digital music collection. 'Locally Stored' means the digital music files you have on your **PC, Mac** or **Network Attached Storage devices (NAS)**.

To stream local content, you will need the following hardware and software running in your network:

1. Your Cambridge Audio Network Player.
2. A mobile device such as a smartphone or tablet on which you can run the StreamMagic app, or by accessing your collection via the front panel controls.
3. A hard drive, computer or NAS containing your compatible digital music files.
4. An active UPnP music or media server.
5. A router which is configured to allow the UPnP service.

Note: The above items must be correctly connected and configured, and it is important to note that depending on the server, NAS, computer, etc. you're using, this will differ from setup to setup. To help you with this we have created best practice guide which should get you up and running with minimal fuss and effort. This can be found [here](#).

MQA (Master Quality Authenticated)

Last updated: October 3, 2024 09:40. Revision #14082

Your player includes MQA technology, which enables you to play back MQA audio files and streams, delivering the sound of the original master recording.



The front panel will display MQA green or blue to indicate that the unit is decoding and playing an MQA stream or file, and denotes provenance to ensure that the sound is identical to that of the source material. It displays MQA blue to indicate it is playing an MQA Studio file, which has either been approved in the studio by the artist/producer or has been verified by the copyright owner.

Settings

Last updated: May 14, 2024 03:12. Revision #12888

Device Name

This is how your player will appear in your StreamMagic app and on your home network when using services like Spotify, Chromecast built-in and TIDAL Connect.

Giving your player a unique name makes it easier to distinguish when using streaming and smart home services.

AirPlay Name

This is how your player will appear when using AirPlay or the Apple Home app.

Standby Mode

This selects what type of standby mode your player will use.

Network Standby means your player will still be controllable by the StreamMagic app and other network services while in standby.

If ECO mode is chosen, your player will use even less power in standby but will need to be switched on either by the front panel or the remote control. It will not be controllable via the app or other network services while in standby.

Automatic Power Down

This sets how long your player will wait while inactive before switching to standby.

Display Brightness

This sets the brightness of your player's display. If set to 'Off' the display will show for a few seconds after any change and then switch off.

Roon Ready DSD

This will allow you to choose how Roon provides DSD content.

Use DoP for digital output - If your device does support native DSD in DoP format.

Use PCM for digital output - If your device doesn't support native DSD.

Control Bus

If your device is connected to a Cambridge Audio amplifier using a control bus connector, volume commands can be sent directly to the amplifier. For more information, please refer to the Getting Connected section of this manual under 'Control Bus' [here](#).

Pre-Amp

With Pre-Amp mode enabled, the volume of the device's analogue outputs can be controlled using the app or rotary dial.

For more information see our [FAQ](#).

Note: Pre-Amp mode and volume control can only be enabled when connected via the analogue outputs.

Volume Limit

This sets the maximum volume that other streaming services like AirPlay, Spotify, TIDAL Connect and Chromecast built-in can set. The front panel, remote control and StreamMagic app volume controls can override this setting.

Early Update

Setting this to 'On' will let you try out the latest firmware ahead of general release.

For more information and to find out what's new visit our [FAQ](#).

Firmware

This will check for and apply any new firmware available for your player.

You can also check for new updates on the info screen and manually update the unit's firmware by following the steps below:

1. Hold down the 'i' (Info) button on the front panel
2. As instructed on the display, press the 'play/pause' button to check for new firmware. The new firmware version will now update if there is one available.

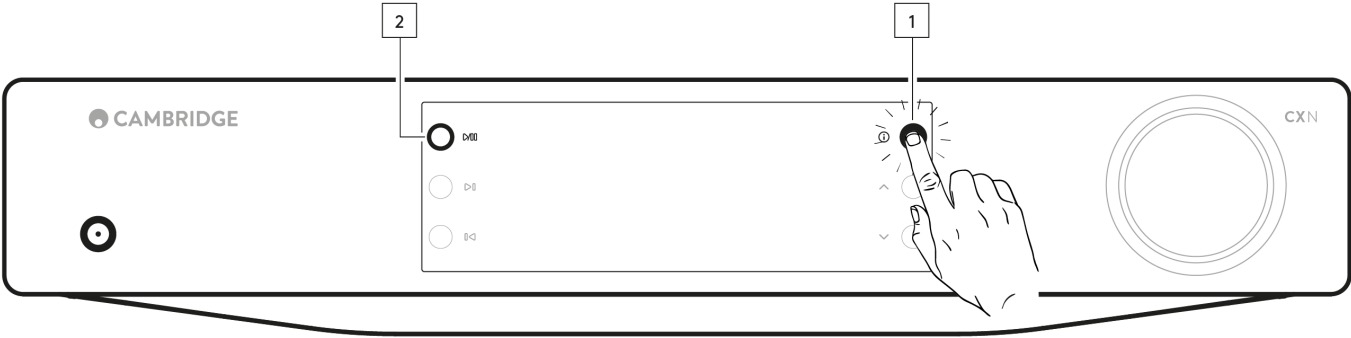

When left in network standby overnight your player will check and apply any new updates.

Note: Your network player must be connected to the internet to carry out firmware updates. You should keep your network player connected to ensure optimal performance.

Restart

This will restart your device and it will briefly lose connection with your network and the app.

Factory Reset

This will return your player to its factory settings.

You can also do this from the info screen by following the steps below:

- 1. Hold down the 'i' (Info) button on the front panel.
- 2. As instructed on the display, hold down the 'reverse skip' button to perform the factory reset.

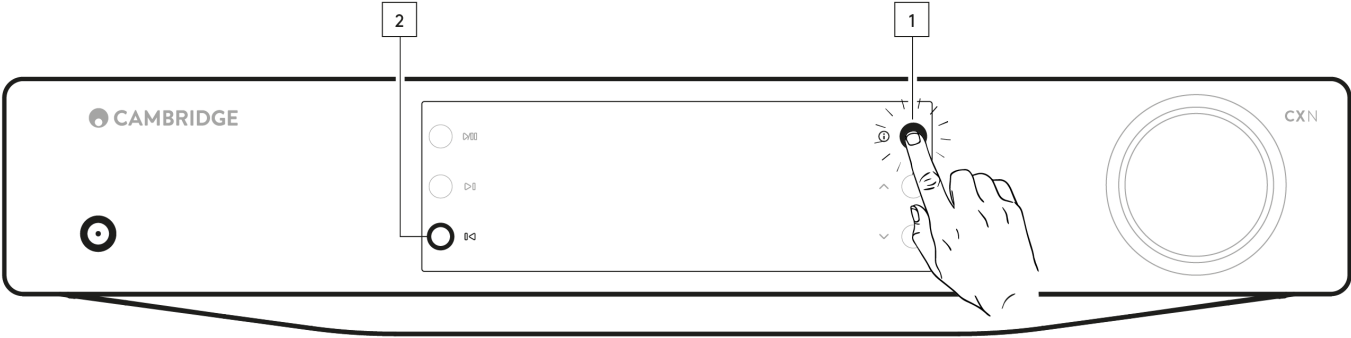

Info screen

Last updated: February 1, 2024 01:38. Revision #11685

The info screen shows useful information about your player, it also allows you to carry out some actions to help resolve problems with your player.

To access the info screen hold the **i** button on the front panel for 2 seconds.

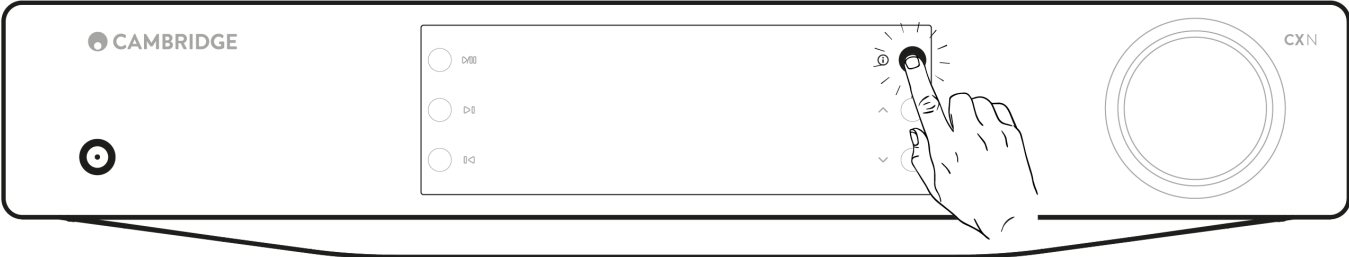

Technical specifications

Last updated: February 1, 2024 01:38. Revision #11686

D/A CONVERTERS

ESS ES9028Q2M

THD @ 1kHz 0dBFS

< 0.0005 %

THD @ 20kHz 0dBFS

< 0.0005 %

FREQUENCY RESPONSE

20Hz-20kHz +/- 0.1dB *

SIGNAL TO NOISE RATIO (REF 1W)

> 120dB

CROSSTALK @ 1kHz

< -120dB

DIGITAL OUTPUTS

S/PDIF Coaxial: 16/24-bit, 32-192kHz

TOSLINK Optical: 16/24-bit, 32-96kHz

AUDIO FORMATS

WAV containing uncompressed, PCM 16-32 bit 32-768kHz, FLAC containing losslessly compressed, PCM 16-32 bit 32-768kHz, Apple Lossless (ALAC) containing losslessly compressed PCM 16-24 bit 32-192kHz, AIFF containing uncompressed, PCM 16-32 bit 32-768kHz, Microsoft® Windows Media TM Audio (WMA 9 Standard) 32-320kbps, MP3 (CBR or VBR) 16-320kbps, AAC, HE AAC and AAC+, (CBR or VBR) 16-320kbps, OGG Vorbis 32-320kbps.
Native DSD64 to DSD512 support.

STREAMING PROTOCOLS

RTSP (Real Time Streaming Protocol), MMS (Microsoft Media Server Protocol), HTTP (Hyper Text Transfer Protocol).

CONNECTIVITY

UPnP, Local USB media, Airplay 2, Chromecast built-in, Internet Radio, Spotify Connect, TIDAL, Qobuz, Deezer, Roon Ready.

PLAYLIST

ASX (Microsoft® playlist format) M3U, PLS

WI-FI

IEEE 802.11 b/g/n or AC (2.4GHz and 5GHz)

WI-FI ENCRYPTION

WEP, WPA, WPA2

ETHERNET

IEEE 802.3, 10 Base-T or 100 Base-T

USB

1 x USB 2.0 current limited to 1A

FILE SYSTEMS

FAT32, NTFS, Ext4, ExFAT

MAINS INLET VOLTAGE

100-240 VAC (switch mode)

STANDBY CONSUMPTION

ECO Mode: <0.5W

Network Standby Mode: >2W

MAX POWER CONSUMPTION

30W

DIMENSIONS

80 x 430 x 325mm (3.1 x 16.9 x 12.8")

WEIGHT

3.55kg (7.8lbs)

Source quality matrix

Last updated: February 20, 2024 04:30. Revision #14097

SOURCE	DELIVERY METHOD	MAXIMUM RESOLUTION
Spotify Connect	Mobile/Desktop App	320kbps
Spotify AirPlay	Mobile/Desktop App	320kbps
Spotify Chromecast	Mobile/Desktop App	320kbps
Spotify Bluetooth	Mobile/Desktop App	aptX HD
TIDAL Connect	Mobile/Desktop App	24bit / 192 kHz
TIDAL (via StreamMagic app)	StreamMagic App	24bit / 192 kHz
TIDAL AirPlay	AirPlay 2	16bit / 44kHz
TIDAL Chromecast	Chromecast	24bit / 48 kHz
TIDAL Bluetooth	Bluetooth	aptX HD
TIDAL Roon	Roon Endpoint	24bit / 192 kHz
TIDAL Roon	USB Class 2	24bit / 192 kHz
TIDAL Desktop App	USB Class 2	24bit / 192 kHz
Qobuz (via StreamMagic app)	StreamMagic App	24bit / 192 kHz
Qobuz AirPlay	AirPlay 2	16bit / 44kHz
Qobuz Chromecast	Chromecast	24bit / 48 kHz
Qobuz Bluetooth	Bluetooth	aptX HD
Qobuz Roon	Roon Endpoint	24bit / 192 kHz
Qobuz Roon	USB Class 2	24bit / 192 kHz
Qobuz Desktop App	USB Class 2	24bit / 192 kHz
Third Party App (via AirPlay)	AirPlay 2	16bit / 44kHz
Third Party App (via Chromecast)	Chromecast	24bit / 48 kHz
Third Party App (via Bluetooth)	Bluetooth	aptX HD

Troubleshooting

Last updated: September 29, 2025 01:47. Revision #14599

If you have trouble connecting the Network Player to your network, these steps may help to resolve the problem:

- Ensure that you have followed the 'Connecting to WiFi' steps in the manual [here](#).
- Ensure both Wi-Fi dongles are securely connected to the rear of the unit.
- Ensure your mobile device is connected to the same network you wish to connect your Network Player to.
- Remove any VPN or Anti Virus app you may have downloaded on your mobile device, as they can sometimes prevent the app from 'seeing' other devices on the network.
- Remove any network switches/extenders etc. that are part of your network set up
- Connect the unit directly to your router via an Ethernet cable.
- Perform a factory reset on your unit, and then attempt the network set up steps again.
- Check that a DHCP server is available, or that you have configured a static IP address on your Player. You can configure a static IP address on the unit via the 'Network' settings in the StreamMagic app.
- Reboot and/or factory reset your router.

If you have trouble connecting the StreamMagic app to your Network Player, these steps may help to resolve the problem:

- Ensure your mobile device is connected to the same network you wish to connect your Network Player to.
- Remove any VPN or Anti Virus app you may have downloaded on your mobile device, as they can sometimes prevent the app from 'seeing' other devices on the network.
- Ensure that you have allowed the StreamMagic app to have access to devices on your network. You can check this via your mobile devices' app settings.
- Ensure both Wi-Fi dongles are securely connected to the rear of the unit.
- Check whether other apps and sources on your device are able to 'see' the unit. If they are, this would suggest that something on your device is preventing the StreamMagic app from 'seeing' the Network Player.
- Download the StreamMagic app on to another mobile device.
- Remove any network switches, extenders, boosters etc. that may be part of your network set up

If your Network Player is experiencing audio dropouts during playback from a network source, these steps may help to resolve the problem:

- Ensure both Wi-Fi dongles are securely connected to the rear of the unit.
- Remove any network switches, extenders, boosters etc. that may be part of your network set up
- Connect the unit directly to your router via an Ethernet cable.
- Reset your network router.
- Perform a factory reset on your Network Player by following the steps in the manual [here](#).

If your Network Player can connect to the network successfully but is unable to play particular Internet Radio stations, it may be due to one of the following causes:

- The station is not broadcasting at this time of the day (remember it may be in a different time zone).
- The station has reached the maximum allowed number of simultaneous listeners.
- The station is not broadcasting anymore.
- The link in our database is simply out of date. (You can request that a radio station is added or updated by following the steps in the following [FAQ](#).)
- The Internet connection between the server (often located in a different country) and you is slow.
- Try using a computer to play back the stream via the broadcaster's web site.
- Try deleting and then re-installing the StreamMagic app on your device.
- Perform a factory reset on your Network Player by following the steps in the manual [here](#).

If you have problems with UPnP playback check the following:

- Ensure your chosen UPnP server software can serve the file type you are trying to access. Some servers do not serve FLAC for instance.
- This Network Player can only play non-DRM files. Files that have DRM controls cannot be played by the CXN100.
- If attempting to play 24-bit WAV or FLAC content, note a wired Ethernet connection is normally preferred for reliable operation due to bandwidth considerations.
- Check the Network Player can play back the file type you are trying to access. WMA, AAC, HE AAC, AAC+, MP3, OGG Vorbis, FLAC, WAV, ALAC, AIFF can currently be played.
- Ensure your PC/NAS drive are connected to the same network as your Network Player.
- Ensure you have followed the required steps for PC/NAS drive configuration with a Network Player. You can find out more about this in the following [FAQ](#).

If you have problems with USB Media playback check the following:

- Check the Network Player can play back the file type you are trying to access. WMA, AAC, HE AAC, AAC+, MP3, OGG Vorbis, FLAC, WAV, ALAC, AIFF can currently be played.
- This Network Player can only play non-DRM files. Files that have DRM controls cannot be played by the CXN100.
- Check that your device does not require more than 1A if it is powered from the USB socket itself.

- Check your device is formatted in FAT32/NTFS/exFAT/Ext4 format.
- The way you organise your USB media affects the size of the internal database the Network Player needs to build dynamically as you browse content. It is good practice to create folders for Artists, within which should be a sub folder for each album containing the tracks for that album. Libraries with thousands of tracks in one folder will progressively slow down the Player's media browsing.

If you have problems connecting a Bluetooth device to the Network Player check the following:

- Ensure the Bluetooth source has been selected via the app or the front panel source selector. You will be unable to pair a Bluetooth device to the Player unless the Bluetooth source has been selected.
- Ensure the supplied Wi-Fi/Bluetooth antenna has been connected to the rear of the Player.
- Ensure your device is not already connected to another Bluetooth speaker/headphones.
- Ensure the Player is not already connected to another Bluetooth device.

MQA tracks do not display as MQA on the front panel:

- Ensure the track you are playing is an MQA track.
- Ensure that you have the required streaming subscription to play MQA files.

There is no sound:

- Ensure the unit is not in Standby mode.
- Check that your amplifier/DAC is properly connected.
- Check that your speakers are properly connected to the amplifier.
- Check that your connected amplifier/DAC is not in mute mode.
- If Pre-Amp mode has been enabled, ensure the Player is not in mute mode.
- Ensure the correct source has been selected via the app or the front panel source selector.

There is no audio when connecting a Mac/PC to the USB Audio input:

- Ensure that all the steps within the [USB Audio](#) section of the manual have been followed.
- Ensure that the USB Audio source has been selected via the app or the front panel source selector.
- Ensure that your PC/Mac is connected to the USB Audio input with a USB A to B cable.
- If you are connecting a PC, make sure that the correct USB driver is downloaded. The driver is available from <https://www.cambridgeaudio.com/gbr/en/driver-updates>.

A TV connected to a digital input has dropouts, glitches or disrupted audio:

- Some TVs have been found to have issues on digital inputs. Enabling 'TV mode' in the StreamMagic app for the digital input connected to a TV should reduce the chance of audio issues from the TV.

Frequently asked questions

Last updated: February 1, 2024 01:37. Revision #11689

Can I play files from a connected USB HD when the CXN100 is not connected to a network?

This is not possible as the use of the StreamMagic app is required to be able to play local files from a connected USB HD.

Please note that it is strongly recommended that the CXN100 is connected to a network at all times.

Does the CXN100 come with a remote control?

No, the CXN100 does not have its own remote control and does not come with one included. The unit can be fully controlled and the settings can be adjusted via the StreamMagic app.

If you wish to use a remote control with your device, the CX series 2 remote control is compatible with the CXN100 and can be purchased from our website [here](#).

Can I access features such as Internet Radio and streaming services via the front panel?

It is not possible to access services and features via the front panel of the CXN100. You will be able to access many features via the StreamMagic app, as well as integrated services such as TIDAL, Spotify etc. via their respective apps.

How do I change the volume of the CXN100?

With Pre-Amp mode enabled within the StreamMagic app device settings, the volume of the device's analogue outputs can be controlled using the app or rotary dial.

Note: Pre-Amp mode and volume control can only be enabled when connected via the analogue outputs.

Do I need to connect both of the supplied Wi-Fi antennas for the CXN100 to work?

Yes, if you are connecting your CXN100 to your network wirelessly, you will need to connect both of the supplied antennas to enable full Wi-Fi functionality and the strongest possible wireless network connection.

Bluetooth functionality will also only be possible when one of the antennas is connected to the port with the Bluetooth symbol.

Can I use more than one of the CXN100's outputs at once?

If you wish to connect the CXN100 to one single device, you can use any output, digital or analogue, that you wish.

If, however, you would like to connect the CXN100 to more than one device at a time, you can connect up to four devices and play simultaneously, as all outputs remain active at all times.

Please note that you will need to enable Pre-Amp mode in the app, if you wish to control the volume via the CXN100.

How do I stop the CXN100 from powering down when not in use?

The CXN100 will automatically switch to standby mode after 20 minutes of inactivity. This Automatic Power-Down (APD) feature can be disabled, by navigating to the device settings within the StreamMagic app.

You can either disable this feature, or edit the length of time it takes for APD to be triggered, by selecting 'Automatic Power-Down'.

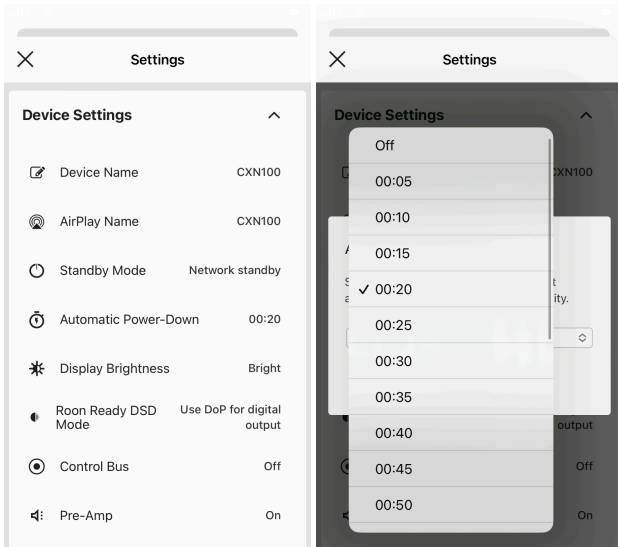

What USB HDs will the CXN100 support?

The primary function of the CXN100 is as a network music player and the USB port is intended for convenient connection of USB HDDs and SSDs. As such, we can not guarantee compatibility with all USB HDDs and SSDs.

The CXN100 will read large capacity hard drives connected to the USB Media input. Some larger capacity drives, however, may require their own power supply, as the player's USB port may not provide enough power for the drive to function.

The CXN100 will support USB hard drives which are formatted to FAT32, exFAT, NTFS and Ext4.

CXA61/81/81 Mk II

Manual Generated: 13/02/2025 - 10:54

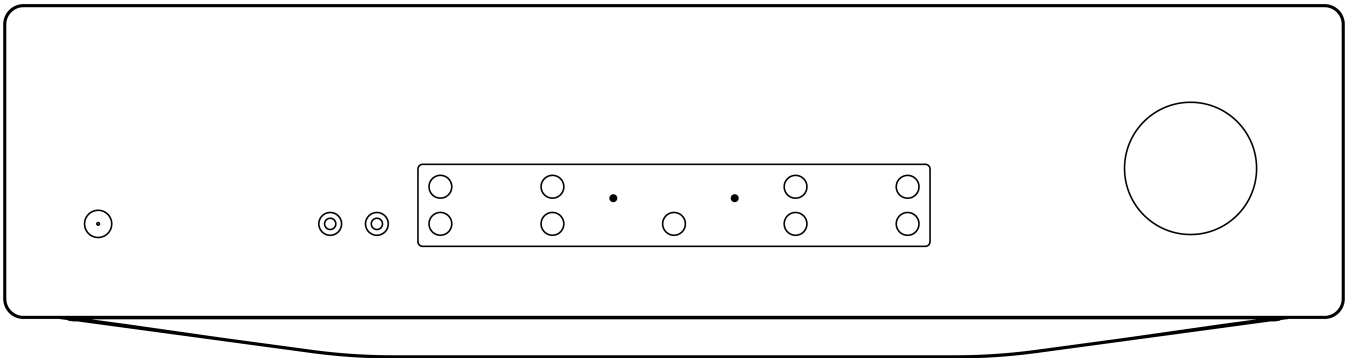

Table of Contents

- CXA61/81/81 Mk II 3
- Introduction 3
- What's included with the CXA61/81? 4
- Front panel controls 5
- Rear panel connections 7
- Remote control 10
- Getting connected 11
- Advanced connections 15
- Setup menu 18
- Bluetooth 20
- Control Bus 22
- CAP5 24
- Troubleshooting 26
- Technical specifications 27
- Frequently Asked Questions (FAQ) 28

CXA61/81/81 Mk II

Last updated: February 13, 2025 10:38. Revision #14221



Users Manual

Introduction

Last updated: May 26, 2022 09:48. Revision #4895

This guide is designed to make installing and using this product as easy as possible. Information in this document has been carefully checked for accuracy at the time of printing; however, Cambridge Audio's policy is one of continuous improvement, therefore design and specifications are subject to change without prior notice.

This document contains proprietary information protected by copyright. All rights are reserved. No part of this manual may be reproduced by any mechanical, electronic or other means, in any form, without prior written permission of the manufacturer. All trademarks and registered trademarks are the property of their respective owners.

The Bluetooth® word mark and logos are registered trademarks owned by the Bluetooth SIG, Inc. and any use of such marks by Audio Partnership Plc is under license. Other trademarks and trade names are those of their respective owners.

Qualcomm is a trademark of Qualcomm Incorporated, registered in the United States and other countries, used with permission. aptX is a trademark of Qualcomm Technologies International, Ltd., registered in the United States and other countries, used with permission.

Qualcomm aptX is a product of Qualcomm Technologies International, Ltd

© Copyright Cambridge Audio Ltd

For upcoming news on future products, software updates and exclusive offers, make sure you register your product at <https://www.cambridgeaudio.com/register>

What's included with the CXA61/81?

Last updated: May 26, 2022 11:24. Revision #4894

Inside the box of your CXA you will receive:

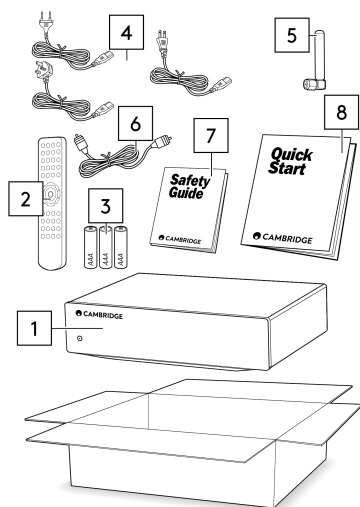

1. CXA Integrated Amplifier
2. Remote Control
3. 3 x AAA Batteries
4. UK power cord (5A fused) (Depending on which country the CXA61/81 was purchased in),
EU power cord (Depending on which country the CXA61/81 was purchased in),
CU power cord (Depending on which country the CXA61/81 was purchased in)
5. Bluetooth Antenna
6. Orange Control Bus Cable
7. Safety Guide
8. Quickstart Guide

Front panel controls

Last updated: June 14, 2022 01:19. Revision #4893

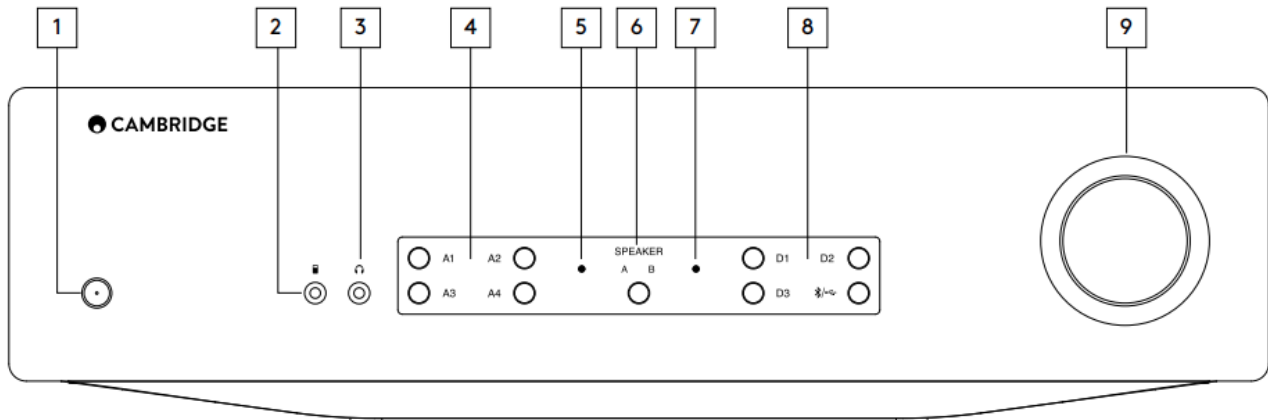

1. Standby/On - Switches the unit between Standby mode (indicated by dim power LED) and On (indicated by bright power LED). Standby mode is a low power mode (0.5 Watts). The unit should be left in Standby mode when not in use.

The CXA has Auto Power Down (APD) enabled by default, and the unit will automatically switch to standby after 20 minutes of inactivity. See the 'Setup menu' section for further details.

2. MP3 input (CXA61 only) - Allows you to connect a portable audio device, such as a smart phone, directly into the front of the unit using the 3.5mm stereo-jack.

Note: The MP3 input can only be selected when a jack is inserted. Plugging in a device into the jack socket automatically selects the MP3 input. With the jack inserted pressing the A4 button will toggle between A4 and MP3 inputs. The MP3 input is shown by A4 being lit orange.

3. Headphones - Allows for the connection of stereo headphones with a 3.5mm jack plug. Headphones with an impedance of between 8 and 600 ohms are recommended.

Note: Plugging in headphones will automatically mute the loudspeaker, pre-out, and sub outputs.

4. Analogue source select buttons - Push the appropriate input selection button to select the source you want.

Notes:

- On the CXA81, pressing the A1 input selection button will toggle between balanced and unbalanced. The balanced input is shown by A1 being lit orange, while the unbalanced input is shown by A1 being lit blue.
- There will be no sound from the amp if the correct input button isn't selected. If an audio source is connected to the balanced input, for example, ensure that the A1 input light is lit orange.

5. Protection indicator - See the 'CAP5' section for further details.

6. Speaker A/B - Press to scroll through the speaker sets connected to the loudspeaker terminals on the back panel (speaker sets A, B or A and B). This can be used for listening to an extra set of loudspeakers in another room. See the 'Connections' section for further details.

7. Mute indicator - The light will flash to show the outputs are muted.

8. Digital source select buttons - Push the appropriate input selection button to select the source that you wish to listen to.

Notes:

- Pressing the Bluetooth/USB button will toggle between the two inputs. The USB Audio is shown by the symbol being lit orange and the Bluetooth source is shown by the symbol being lit blue.
- There will be no sound from the amp if the correct input button isn't selected. If an audio source is connected to the USB Audio input, for example, ensure that the Bluetooth/USB button is lit orange.

9. Volume - Use to increase/decrease the level of the sound from the outputs of the amplifier. This control affects the level of all outputs.

Rear panel connections

Last updated: May 14, 2024 12:47. Revision #12775

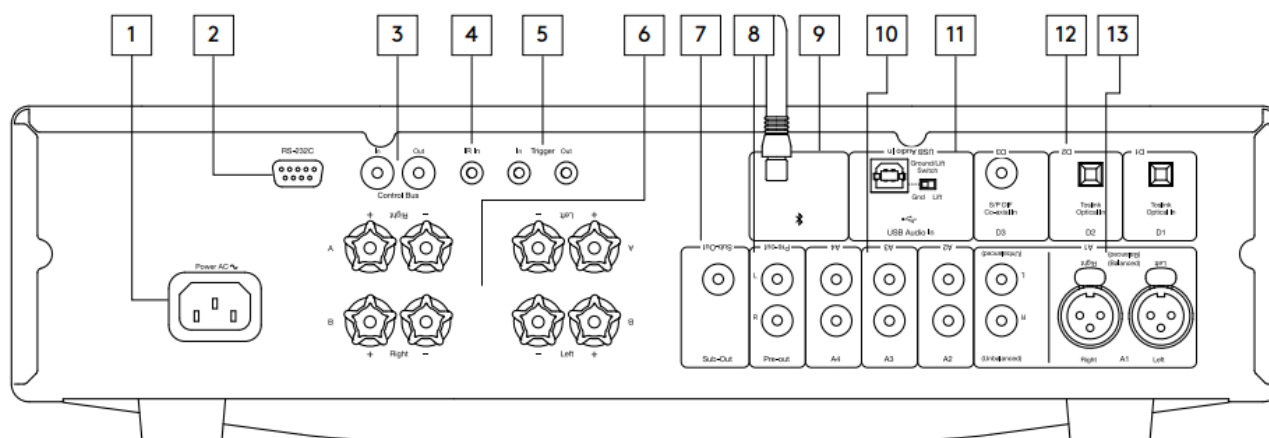

1. AC power socket - Once you have completed all connections to the amplifier, plug the AC power cable into an appropriate mains socket then switch on. Your amplifier is now ready for use.

2. RS232C - RS232 is a standard serial data communication protocol, which allows devices that support RS232 to communicate with each other as part of a home automation system.

Custom install control - a full protocol is available for the CXA on our website [here](#).

3. Control bus - RCA sockets used to send and receive power and volume commands from other connected CX Series products. For more information on the Control Bus, see 'Control Bus' section.

4. IR in - Allows modulated IR commands from an IR repeater or custom install systems to be received by the amplifier. Commands received by the IR In socket are not looped out of the Control Bus.

Note: The IR input doesn't provide any power, so any device connected to this input will need to have its own power source.

5. Trigger in/out - The CXA can be connected to the trigger control output of home automation equipment to control the power state of the CXA. The input level should be 12V.

The trigger out provides a continuous 12v, this is active while the CXA is powered on. This can be used to turn on other equipment that has a trigger in.

6. Speaker terminals

Note: When using a banana plug, make sure the speaker terminals are completely tightened before inserting the plug.

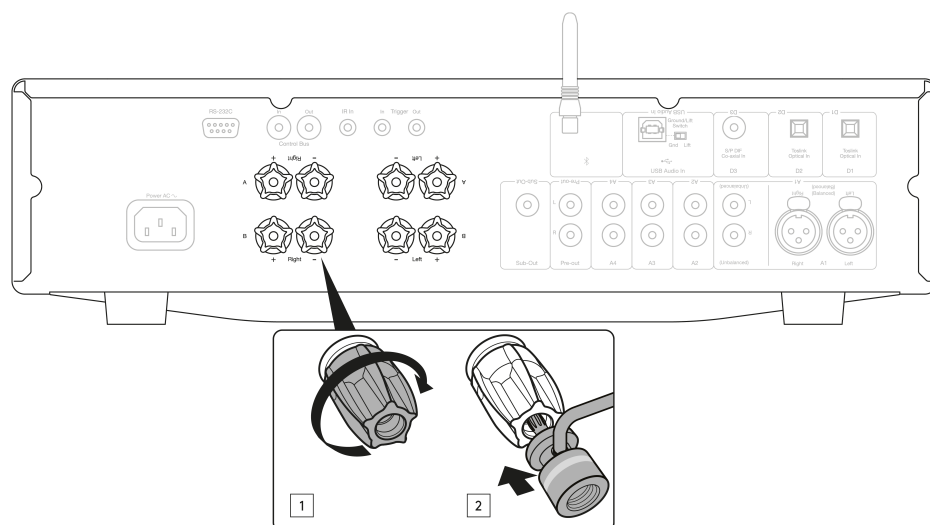

Two sets of loudspeaker terminals are available:

A (main loudspeaker terminals)

and

B (secondary loudspeaker terminals).

Connect the wires from your left channel loudspeaker to the left terminals on the CXA, and the wires from your right channel loudspeaker to the right terminals on the CXA.

Always ensure that the positive connection on the amplifier is connected to the positive connection on the speaker and the negative connection on the amplifier is connected to the negative connection on the speaker.

The Red terminal is the positive output.

The Black terminal is the negative output.

Care should be taken to ensure no stray strands of wire short the speaker outputs together. Please ensure that the loudspeaker terminals have been tightened completely to provide a good electrical connection.

It is possible for the sound quality to be affected if the screw terminals are loose.

Note: The speaker terminals will need to have the round pips removed before you can insert a banana plug into them.

7. Sub out - Connect to the input on an active subwoofer, if required.

Note: There is a low pass filter of approximately 2.3 kHz applied to the Sub Out, no frequencies above 2.3 kHz will be sent to a subwoofer connected to this output. This is so that there is minimal phase added by the CXA at the Sub Out frequencies.

The crossover frequency can be adjusted on the Subwoofer itself.

8. Pre-out - For connection to the unbalanced inputs of a power amplifier or active subwoofer.

Note: There is not a low pass filter applied to the Pre-Out, so the full frequency range will be sent to a subwoofer connected to the Pre-Out.

9. Bluetooth antenna - Used for Bluetooth audio streaming. See 'Bluetooth' section for details.

10. Analogue inputs (A1 Unbalanced, A2, A3 and A4) - Suitable for any 'line level' source equipment such as CD players, DAB or FM/AM tuners etc.

These inputs are for analogue audio signals only. They should not be connected to the digital output of a CD player or other digital devices.

Note: For the balanced XLR inputs, pin1 is ground, pin2 is positive and pin3 is negative.

11. USB audio in - A USB B type socket to enable the playback of audio from a computer running either Microsoft Windows or Apple Mac OS X operating systems. Some builds of Linux are also suitable.

Notes:

- Always use a high-quality USB connection cable certified as USB Hi-Speed. USB cable connections longer than 3m may result in inconsistent audio performance.
- Always turn the volume to minimum, switch to another input or turn the CXA off before plugging/unplugging cables to the USB input or whilst booting up/shutting down your PC/Mac.

Ground/Lift switch - The Ground/Lift switch enables the USB interface earth to connect or disconnect the CXA signal ground. Disconnecting (lifting) the earth can be useful if electronic hum is heard through the speakers when the USB input is selected. The switch should otherwise be left in the Ground position.

12. Digital inputs (D1, D2 AND D3) - TOSLINK and S/P DIF co-axial digital inputs.

Coaxial - Use a high quality 75 ohm digital RCA Phono interconnect cable (not one designed for normal audio use). This input is suitable for 16-24 bit content up to 192kHz.

TOSLINK optical - Use a high quality TOSLINK fibre optic interconnect cable designed specifically for audio use. This input is suitable for 16-24 bit content up to 96kHz (TOSLINK is not recommended at 192kHz sampling rates).

Note: To obtain the best results from your system we recommend using only high-quality Cambridge Audio interconnects. This will ensure that you hear your system as we designed it. Please ask your dealer for details.

13. A1 inputs

Note: Balanced (XLR) is available on the CXA81 only.

A1 inputs feature either unbalanced (phono/RCA) or balanced (XLR) connections. The balanced connection is the higher quality option and can reject noise and interference in the cable when used with other equipment that supports this function.

An XLR connector is wired Pin 1 - Ground; Pin 2 - Hot (in-phase); Pin 3 - Cold (phase-inverted).

Remote control

Last updated: July 12, 2022 01:13. Revision #5136

The CXA remote control handset duplicates the front panel control functions and is also able to control other CX series products. The supplied AAA batteries must be fitted before the remote control can be used. The handset buttons function as described below:

1. Brightness - Alters the brightness of the CXA display lights. There are two brightness levels and an option to switch off the backlight.

Note: When the CXA display lights are selected to be off, selecting any of the functions will briefly switch on the lights to show the change.

2. Mute - Press to mute or unmute the loudspeakers, pre-out, sub, and the headphone outputs.

The light will flash on the front of the unit to show the outputs are muted.

3. Standby/On - Switches the CXA between On and Standby mode.

4. Sources - Used to select the source inputs.

Note: For the CXA81, the A1 button has the double function of selecting the balanced or unbalanced A1 input, and will toggle between the two inputs when double pressing. The MP3 source can only be selected when there is a jack connected to the input.

5. Volume up/down - Volume level adjustment.

Note: If the remote control will not function, please check that the batteries have not expired, and that there is nothing blocking the front panel IR receiver.

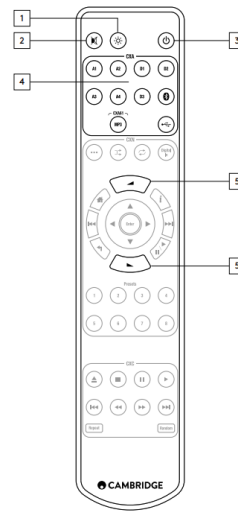

Getting connected

Last updated: November 11, 2022 10:55. Revision #7753

When designing our amplifiers, we include features that allow you to connect your system in various ways. The inclusion of features such as Pre-Out and Speaker B connections mean that you can flexibly configure your system depending on your requirements.

Note: When using a banana plug, make sure the speaker terminals are completely tightened before inserting the plug.

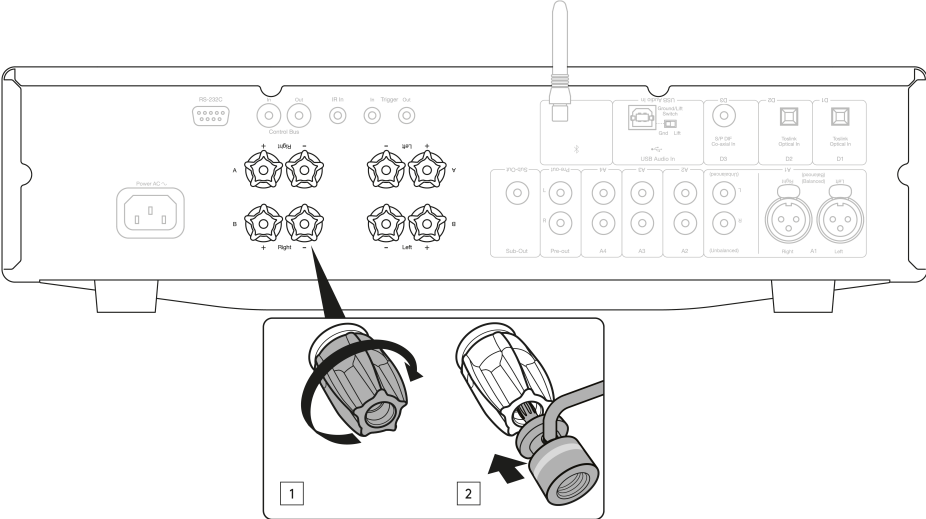

Basic connections

The diagram below shows the basic connection of your amplifier to a CD player using the D3 coaxial digital input source and a pair of loudspeakers.

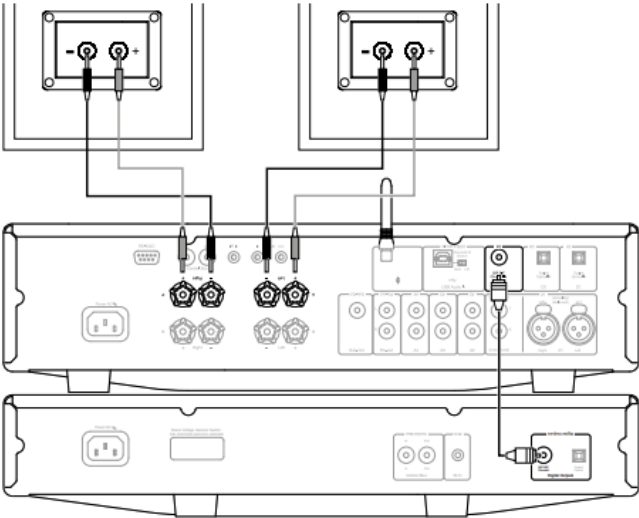

Speaker B connections

The Speaker B connections on the back of the amplifier allow for a second set of speakers to be used (i.e. speakers located in another room). The Speaker A/B button on the front panel scrolls through the selection of speaker A only, speaker B only, and speaker A and B together.

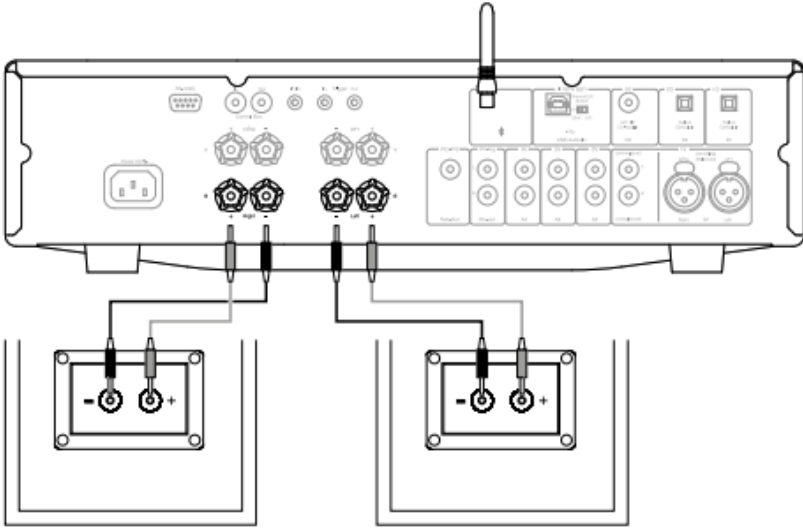

Sub out connections

The Sub Out is for connecting to the LFE/Sub input of an active subwoofer. The diagram below shows how to connect the amplifier to an active subwoofer via the LFE/Sub input on the subwoofer.

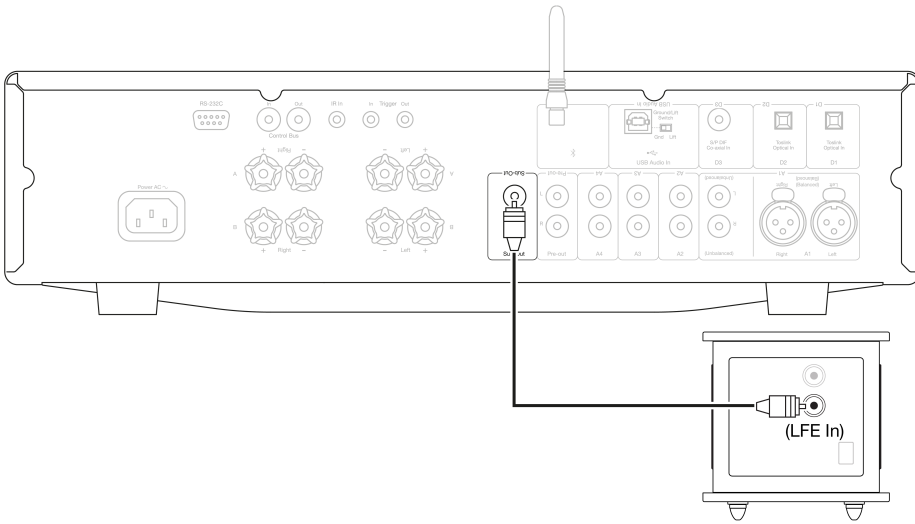

Preamp out connections

The Preamp Out sockets are for connecting to the input sockets of a power amplifier or active subwoofer. The diagram below shows how to connect the amplifier to an active subwoofer via the Line In inputs on the subwoofer.

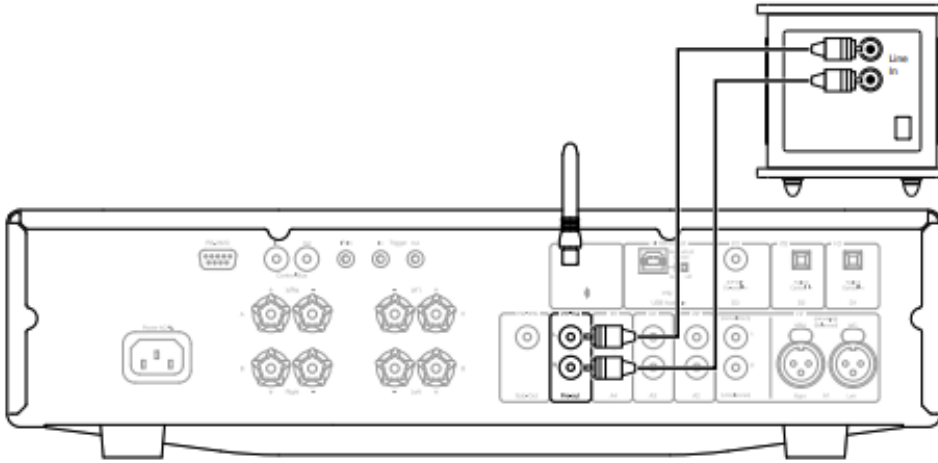

Balanced audio connections (CXA81 only)

The diagram below shows how to connect the CXA81 to the CXN Network player using the Balanced Audio inputs via three pin XLR connectors. The CXA81 can also be connected to non-Cambridge Audio sources with balanced outputs.

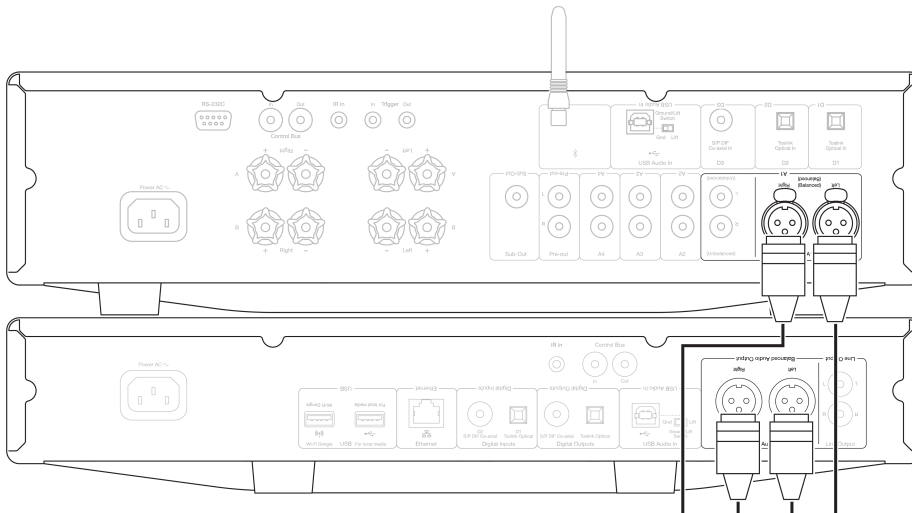

Balanced connections in an audio system are designed to reject electrical noise, from power wiring etc, and also the effects of noise currents flowing through ground connections. The basic principle of balanced interconnection is to get the signal you want by subtraction, using a three wire connection. One signal wire (the hot or in-phase) carries the normal signal, while other (the cold or phase-inverted) carries an inverted version. The balanced input senses the difference between the two lines to give the wanted signal. Any noise voltages that appear identically on both lines (these are called common-mode signals) are cancelled by the subtraction.

The CXA81 is designed to work at its highest performance when a balanced interconnect is used.

Note: To select the balanced input on the CXA81, press the A1 button twice on the front panel or on the remote control so that the A1 light on the front panel display lights up Orange. Repeatedly pressing the A1 button will toggle between balanced and unbalanced inputs.

Connecting a TV

A TV can be connected to one of the digital inputs on the CXA, as long as the TV has the required Optical or Coaxial output.

Ensure that the output audio settings on the TV are set to PCM or Stereo, as the CXA is only able to decode a Stereo signal.

Please also ensure that the digital input that the TV is connected to has been selected on the front panel of the CXA (D1, D2 or D3).

Enabling 'TV Mode' within the CXA:

Some Connected TVs will send an inconsistent sample rate to the CXA, that the DAC inside the amplifier is unable to process. This can result in audio dropouts and glitches. If this is the case with your CXA, 'TV Mode' will need to be enabled within the amplifier.

The serial number for your CXA61 and CXA81 will indicate whether or not 'TV Mode' is already pre-installed or whether this will require manual installation.

Pre-Installed (October 2020 Onwards):

The serial numbers for units that contain 'TV Mode' pre-installed are laid out as such; 'KW C11125 **7060** 0001'. If the third set of numbers are or are greater than **7060**, this indicates that your amplifier was manufactured after October 2020 and already has 'TV Mode' installed.

To enable 'TV mode' on Pre-Installed units:

1. Enter the Setup menu by putting the CXA in standby mode.
2. Whilst in Standby mode, press and hold the Speaker A/B button until the A/B lights flash alternatively and the sources A1-A4 light up.

See below source buttons for setup configuration:

Note: Button selected (on) is represented by Blue light.

A2 off - The CXA is set to the best digital input audio setting on input D2.

A2 on - The CXA is set to a more tolerant digital input setting for input D2 that should reduce the chance of having the signal intermittently drop.

3. To save the setup settings and exit the setup menu, press the Speaker A/B button.

Note: Pressing the Standby/On button while in the setup menu will exit this setup menu and will not save the setup settings.

Uninstalled (Pre October 2020):

If your CXA pre-exists the above stated serial number combination (the third set of numbers is lower than 7060), then please contact our support team at <https://www.cambridgeaudio.com/gbr/en/contact> and we will be able to provide you with instructions on how to perform this update manually.

Please note: Your TV will have to be connected to TOSLINK OPTICAL input D2 for TV Mode to work.

Advanced connections

Last updated: May 14, 2024 12:49. Revision #12784

USB audio connection

The CXA USB Audio input enables the playback of audio from Microsoft Windows or Apple Mac OS X personal computers (and some Linux builds).

When connected via a USB cable, the computer will identify the CXA as an audio device. Specifying the CXA in the computer's audio control panel, will enable it to play audio data either stored locally on the computer or streamed to the computer via a network or the internet.

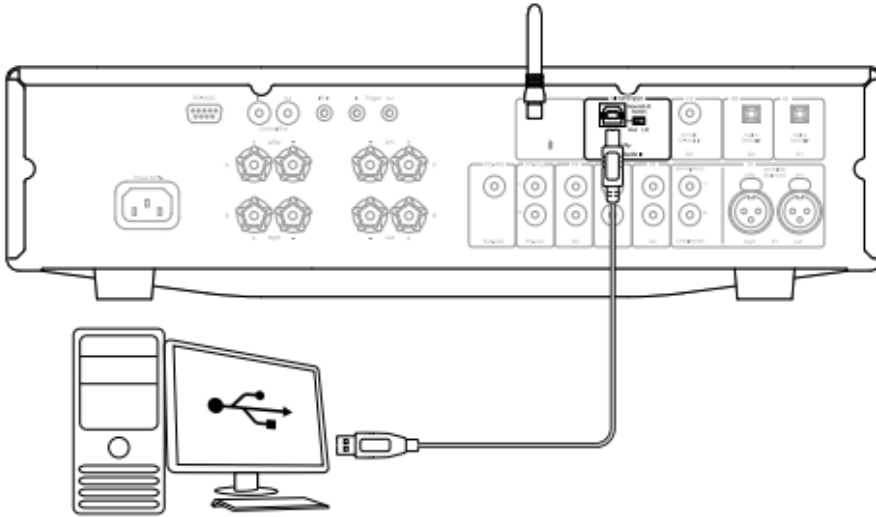

Important Note: Always turn the volume to minimum, switch to another input or turn the CXA off before plugging/unplugging cables to the USB input or whilst booting up/shutting down your PC/Mac.

Note: Always use a high quality USB 'A to B' cable certified as USB Hi-Speed. USB cable connections longer than 3m may result in inconsistent audio performance.

The CXA is both USB 2.0 (Hi-Speed) and USB 1.1 (Full-speed) USB port compatible.

It should also work with USB 3.0 ports where the PC will simply treat the CXA as if it were a USB 2.0 or 1.1 device.

The CXA supports two USB Audio protocols (not the same as the port types themselves):

- USB Audio Class 1 (which works over USB 1.1 ports and supports up to 24-bit/96kHz)
- USB Audio Class 2 (which requires a USB 2.0 port and can support up to 24-bit/384kHz)

The default configuration is USB Audio Class 2.

How to connect a Windows PC to the CXA via the USB audio input

With the CXA switched to USB Audio Class 1, the CXA will work with Windows 7 or above and accept audio up to 24-bit/96kHz.

With the CXA switched to USB Audio Class 2, the CXA needs the Cambridge Audio USB Audio 2.0 Driver to be loaded and can then accept up to 24-bit/384kHz.

1. With the CXA in Standby mode and/or the volume set to minimum, connect your PC to the CXA via a USB A to B cable.
2. For the highest quality play back, ensure that the CXA is set to USB 2.0 mode.

See the 'Setup Menu' section below for a guide on how to change USB mode. (The default configuration is USB Audio Class 2)

3. Download the Windows USB 2.0 driver.

See the "How do I install the latest USB Audio driver" section below, for a guide on how to download the USB driver.

4. Select the USB Audio source on the front panel of the CXA.

You can do this by pressing the Bluetooth/USB button, which will toggle between the two inputs. The USB Audio is shown by the symbol being lit orange.

5. Choose the CXA as your output speaker via your Windows PC's sound settings.

Note: To ensure you are getting the highest quality play back possible, ensure that the maximum sample rate for the CXA is selected, up to 384 kHz.

This can be done via your Windows PC by selecting 'Control Panel' > 'Sound' > 'Speaker Properties' > 'Advanced' Tab, and selecting the maximum sample rate and bit depth from the drop down menu.

How to install the latest USB audio driver for the CXA61/81

To install the latest USB Audio driver for your CXA61/81, please follow the steps below:

1. Download the correct driver for your Windows operating system from - <https://www.cambridgeaudio.com/gbr/en/driver-updates>
2. Unzip the downloaded folder, and double click on the application file to run the installer. This is highlighted in the image below.

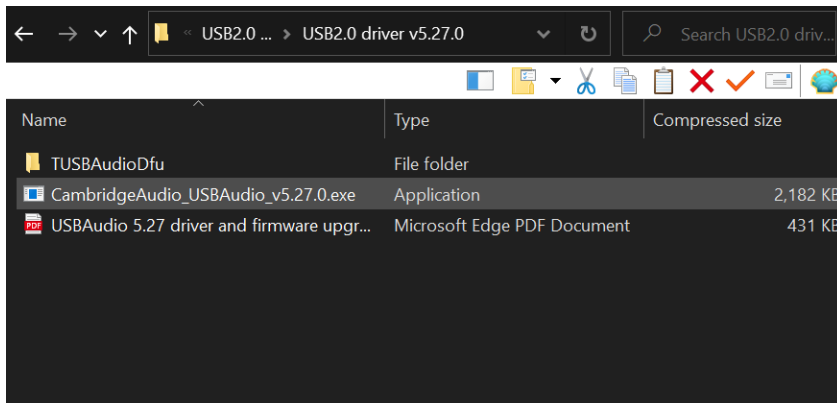

3. Run the installer, and follow the instructions.

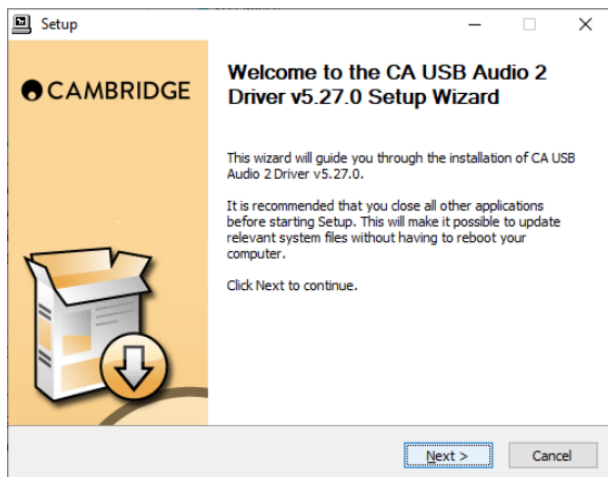

4. Allow the update to progress, click next, and then finish to complete the installation.

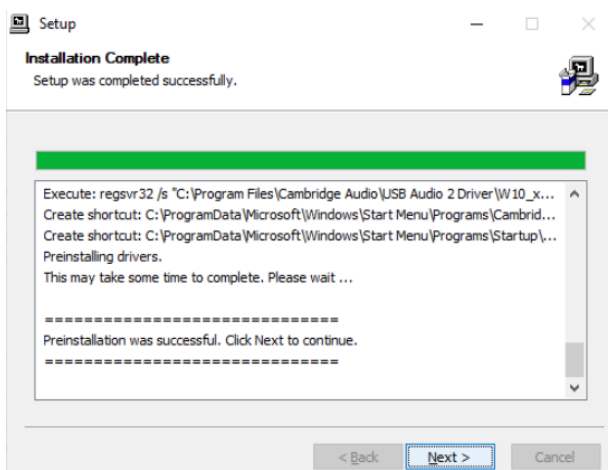

5. Confirm the installation by opening the CA Control Panel, and checking the driver version.

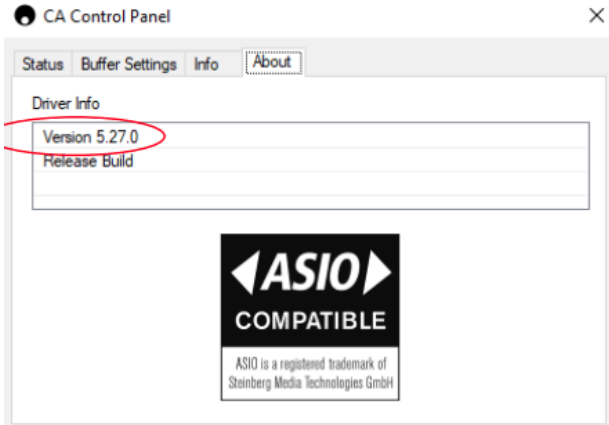

How to connect an Apple Mac to the CXA via the USB audio input

No extra drivers are required. With the CXA switched to USB Audio 1.0 the CXA will work with the native Mac OS-X 10.5 (Leopard) or above Audio 1.0 driver and accept audio up to 24-bit/96kHz.

With the CXA switched to USB Audio Class 2 the CXA works with the native Mac OS-X 10.5 (Leopard) or above Audio 2.0 driver and can accept audio up to 24-bit/384kHz.

1. With the CXA in Standby mode and/or the volume set to minimum, connect your Mac to the CXA via a USB A to B cable, or C to B cable depending on the USB ports on your Mac.
2. Select the USB Audio source on the front panel of the CXA.

You can do this by pressing the Bluetooth/USB button, which will toggle between the two inputs. The USB Audio is shown by the symbol being lit orange.

3. Choose the CXA as your output speaker via your Mac's sound settings

Note: To ensure you are getting the highest quality play back possible, ensure that the maximum sample rate for the CXA is selected, up to 384 kHz.

This can be done via your Mac by selecting 'Audio Midi Setup > 'Sound' > 'Speaker Properties' > 'Advanced' Tab, and selecting the maximum sample rate and bit depth from the drop down menu.

Use with Linux

For most builds of Linux with the CXA switched to USB Audio Class 1 the CXA will work with the native Audio 1.0 driver and accept audio up to 24-bit/96kHz.

Some very new builds of Linux are now supporting USB Audio Class 2 for which the CXA should be switched to Audio 2.0 to accept audio up to 24-bit/384kHz.

For both cases because Linux builds vary according to their creators choice of software components including drivers it is not possible to guarantee operation and Audio drivers may need to be loaded.

'Class drivers' as they are called for generic support of Audio Class 1.0 or Audio Class 2.0 devices may be available from the Linux community, we do not supply these.

Note: It is not possible to connect a USB drive or HDD directly to the CXA61/81 via the 'USB Audio' input. The 'USB Audio' input on the CXA61/81 will only support a direct connection with a PC or Mac. You will, however, be able to use one of our [network players](#) in combination with the CXA61/81 to do this.

Setup menu

Last updated: June 6, 2022 08:54. Revision #4888

To enter the setup menu

1. Put the CXA in standby mode.
2. Whilst in Standby mode, press and hold the Speaker A/B button until the A/B lights flash alternately and the sources A1-A4 light up.

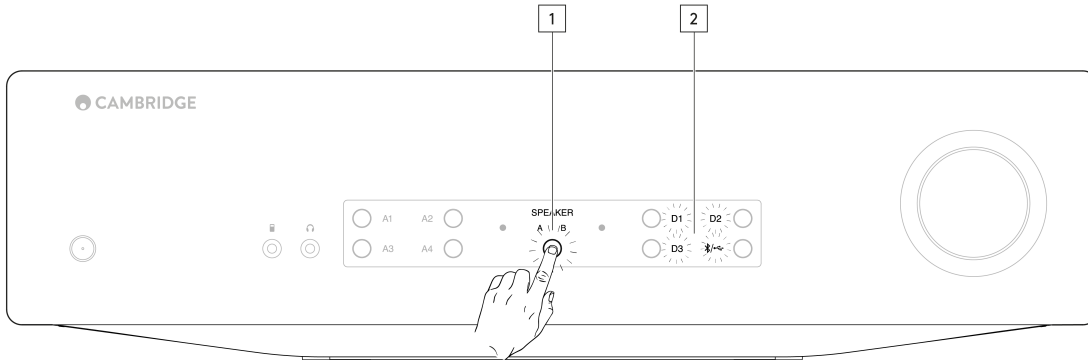

Note: Press the Speaker A/B button once to leave the Setup menu and place the CXA back into Standby mode.

See below source buttons for setup configuration:

Note: Button selected is represented by Blue light.

Auto power down (APD)

A1 off - Disables the APD (Auto power down) function.

A1 on - Sets the APD time to 20 minutes.

Note: Auto power down is a power down function that automatically switches the CXA into standby mode if there is no audio. The APD time represents the amount of time required for there to be no audio before the CXA is automatically put into the standby mode.

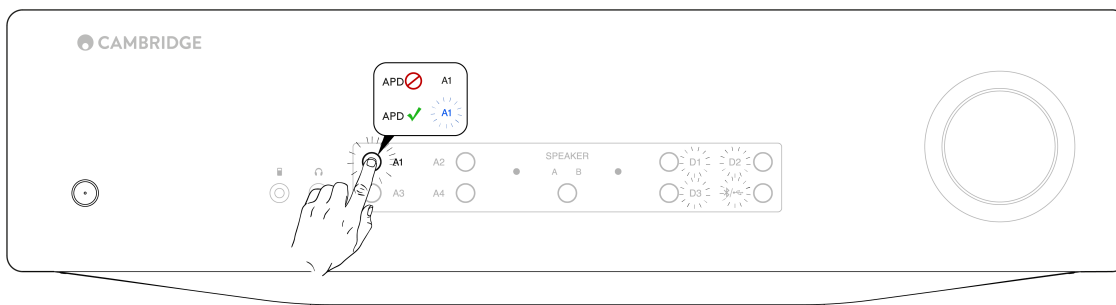

Clipping function

A3 on - Clipping function enabled. The volume nudges down if signal clipping is detected.

A3 off - Clipping function is disabled.

USB mode

A4 on - Puts the CXA in USB Audio Class 2 mode.

A4 off - Puts the CXA in USB Audio Class 1 mode.

Notes:

- To save the setup settings and exit the setup menu, press the Speaker A/B button.
- Pressing the Standby/On button while in the setup menu will exit this setup menu and will not save the setup settings.

Factory reset

A factory reset can be performed to restore the CXA to its original factory settings:

1. Whilst the CXA is in standby mode, press and hold the speaker A/B button;
2. Then when the A/B lights flash, press D1, D3, USB, D2 in a U shape sequence.

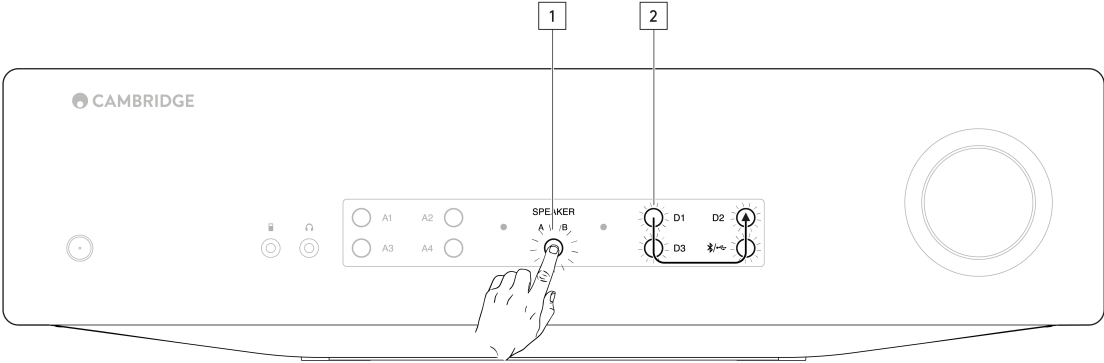

Bluetooth

Last updated: June 6, 2022 08:55. Revision #4887

Bluetooth audio streaming

Selecting this allows the CXA to receive Bluetooth audio from most phones, tablets and laptops.

Pairing

To begin streaming high quality music from your device it will first need to be paired with the CXA. Select the Bluetooth source on the CXA to enter discovery mode.

Notes:

- Your device can only be paired and connected to the CXA while the Bluetooth source is selected. This can be done by selecting the Bluetooth/USB source button on the front panel. The Bluetooth source is shown as being selected by the symbol being lit blue.

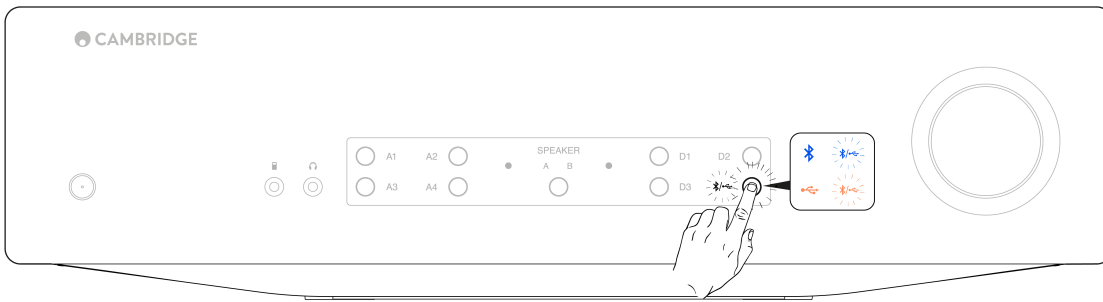

- The CXA is always in discoverable mode when there is no Bluetooth connection. Discoverable mode means that the CXA is able to be paired to another Bluetooth device.
- The supplied Bluetooth antenna must be inserted into the rear of the unit to enable Bluetooth functionality.

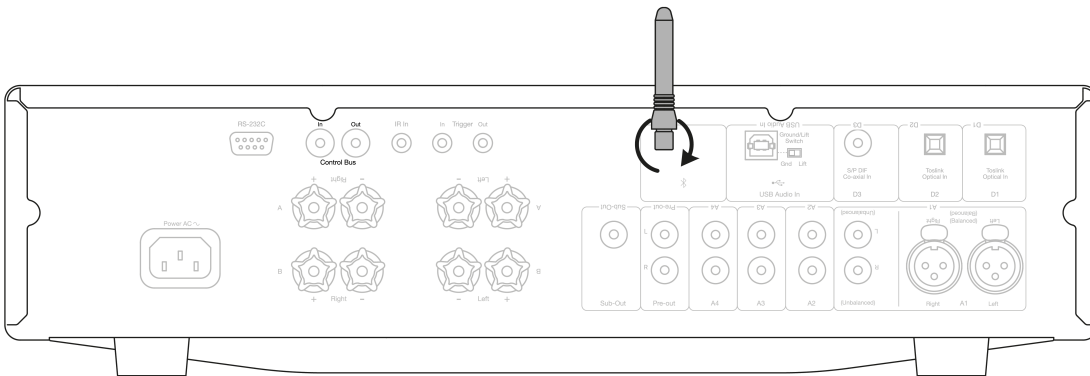

Bluetooth troubleshooting guide

If you are having problems connecting your Bluetooth device to the CXA, please try the following troubleshooting steps:

- Ensure that the supplied Bluetooth antenna is properly connected to the back of the unit. The CXA61/81 will be unable to connect to a Bluetooth device without the antenna connected. Try disconnecting and then re-connecting the antenna.
- Ensure that the Bluetooth source has been selected by selecting the Bluetooth/USB Audio button on the front panel. The Bluetooth source is shown by the symbol being lit blue. When the USB source is active the LED will be orange.
- Ensure that your Bluetooth device is in pairing mode and not already connected to another Bluetooth unit.
- Forget the CXA from your devices' list of discoverable Bluetooth items and start the pairing process again.
- Perform a factory reset on the CXA (see 'Factory Reset' section above).

Control Bus

Last updated: June 6, 2022 08:56. Revision #4896

The Control Bus allows any compatible Cambridge products to synchronise when powering up the units. See the following diagrams when connecting the CXA using the provided Control Bus cable.

Another added feature with this Control Bus is the use of the StreamMagic app. You can use the StreamMagic app to control the CXA via the CXN.

StreamMagic app (via CXN)

When using the app to turn the CXN on/off, this will also turn the CXA on/off. The app can also be used to control the volume of the CXA. Connect the CXN control bus out to CXA in. For more information, see the CXN manual.

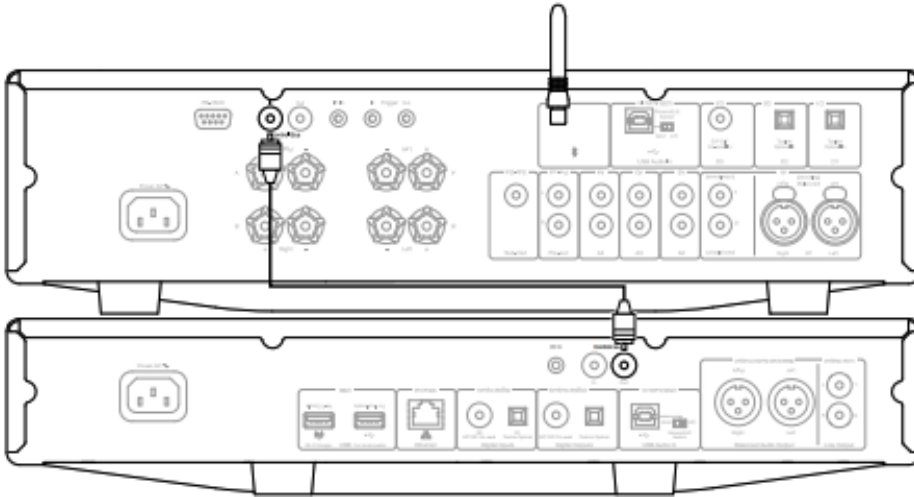

CXA with CXC

When turning the CXC on/off, this will also turn the CXA on/off. Connect the CXA control bus out to CXC in.

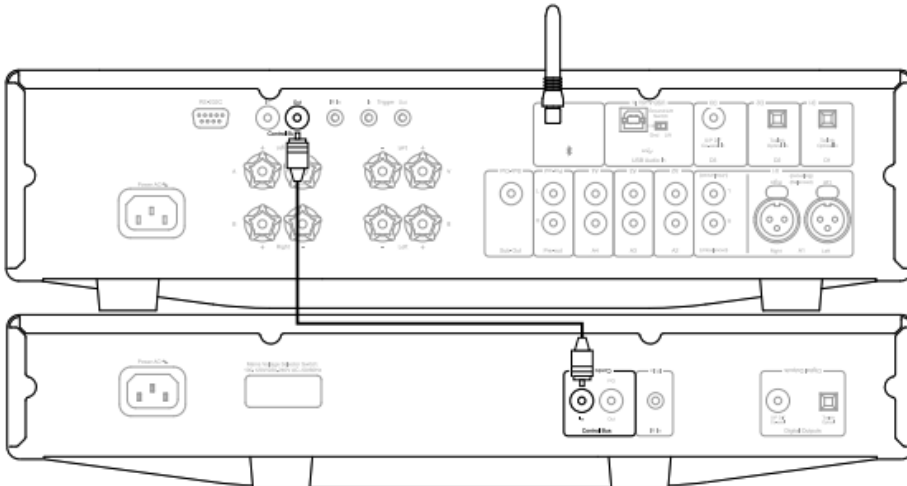

CXA with CXN

Note: Without using the StreamMagic app to control the CXA.

When turning the CXA on/off, this will also turn the CXN on/off. Connect the CXA control bus out to CXN in.

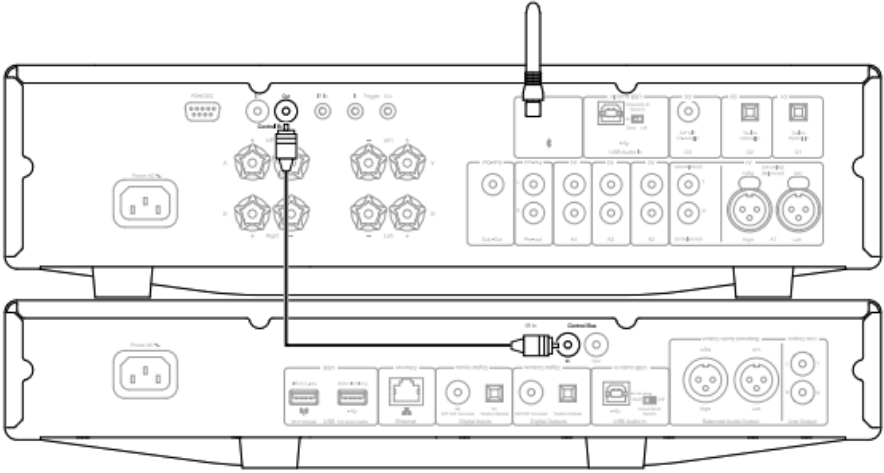

CXA with CXN and CXC

When turning the CXN on/off, this will turn the CXA and CXC on/off.

With all three CX devices, connect the CXN Control Bus out to CXA Control Bus in. Then connect the CXA Control Bus out to CXC Control Bus in.

Note: Do not loop back from the CXC Control Bus out to the CXN Control Bus in.

Control Bus will also need to be enabled and set to 'Amplifier' within the CXN device settings in the StreamMagic app, once the app has been connected to the CXN.

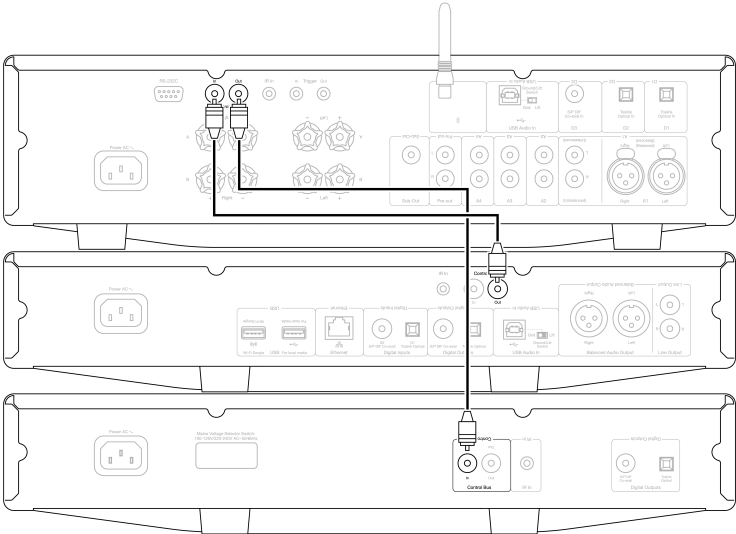

Note: The CXA, CXN and CXC all have an Auto Power Down (APD) function. If APD is enabled and one of the devices is switched on but inactive, the device will automatically power down after the selected APD time. This will then switch off all the other connected devices, due to the Control Bus connection.

If you don't want the devices to go into standby automatically, we would recommend disabling the APD feature on each device.

CAP5

Last updated: June 6, 2022 08:58. Revision #4897

Cambridge Audio has developed a proprietary protection system to ensure reliability and a long life for its amplifiers and the speakers they are connected to. This protection system comprises of five main protection methods:

1. DC detection

Indication - Unit has switched off during operation. The front panel LED light flashes together in the following sequence, one flash with long pause between flashes. Read below for more information.

Description - CAP5 offers loudspeaker protection if the output of the amplifier goes to a high constant voltage (DC) because of some internal fault. This is a rare fault although detecting it could just save those expensive loudspeakers.

Remedy - Due to the necessary sensitivity of the DC protection circuit, extremely hard clipping of the amplifier may cause DC protection to be triggered. If this fault occurs, please contact your dealer for service.

2. Over temperature detection

Indication - Unit has switched off during operation. The front panel LED light flashes together in the following sequence, two quick flashes with long pause between flashes. Read below for more information.

Description - Over temperature is caused by a combination of high listening levels and low impedance speakers. CAP5 includes temperature detection which constantly monitors the heat generated by the output transistors. If the monitored temperature reaches a high level (suitably within the limits of the output devices) the amplifier will automatically switch into a fault mode. The unit should ideally be left for 15 minutes in this state to cool down adequately. If the unit has not fully cooled down then the temperature may reach the limit soon after the amplifier is powered up. If the loudspeaker impedance is low the temperature of the amplifier may rise faster as the amplifier is working harder. If the amplifier is mounted in a cabinet or the ventilation slots are obstructed the over temperature detection may activate/reactivate after a short listening time.

Remedy - The internal temperature of the output transistors has reached the over temperature limit. Leave the unit for 15 minutes to cool down before pressing the Standby button to resume normal operation.

3. Overvoltage/Overcurrent detection

Indication - Unit has switched off during operation. The front panel LED light flashes together in the following sequence, three quick flashes with long pause between flashes. Read below for more information.

Description - CAP5 offers V/I (voltage/current) protection by constantly monitoring the output transistors to keep them working inside their Safe Operating Area (SOA). The SOA is a set of limits given by the output transistor manufacturer to ensure reliability. The V/I protection has been incorporated within the amplifier circuitry to provide a fast response to temporary overload conditions. When the V/I protection is triggered the unit will continue to operate but distortion may be heard as the unit protects the output transistors.

Remedy - Reduce the volume. If distortion is still present, check the speaker connections and ratings.

4. Short circuit detection

Indication - Unit has switched off during power up. The front panel LED light flashes together in the following sequence, four quick flashes with long pause between flashes. Read below for more information.

Description - During power up from Standby CAP5 performs a check on the loudspeaker terminals to see if a short across the terminals has been accidentally introduced. If the resistance measured across the loudspeaker terminals is too low the unit will stay in Standby mode until the fault has been removed and Power up is re-attempted.

Remedy - There may be a short circuit between the loudspeaker terminals. Check all loudspeaker connections before attempting to switch the unit out of Standby.

5. Intelligent clipping detection

Indication - Volume is reduced automatically.

Description - CAP5 has the ability to detect when the amplifier starts to clip or overdrive at its output, which can damage loudspeakers, and degrade the sound. Clipping distortion is caused at high volume levels when the output signal attempts to go outside the maximum voltage that the amplifier can provide, causing the tops of the signal to flatten off. When CAP5 detects clipping the volume will be automatically reduced down until CAP5 detects an undistorted output.

Note: The clipping detection is disabled by default. The clipping detection can be enabled in the Setup menu (see 'Setup menu' section).

If CAP5 is persisting, it is also advisable to check the specifications of your speakers to ensure that they are compatible with the CXA61/81. Both amplifiers can be used with speakers with an impedance of between 4 and 8 Ohms.

The CXA61 outputs 60W RMS into 8 Ohms and 90W RMS into 4 Ohms, while the CXA81 outputs 80W RMS into 8 Ohms and 120W RMS into 4 Ohms.

If your connected speakers fall outside of these specifications, then this could also be a reason for CAP5 protection being activated.

Troubleshooting

Last updated: May 14, 2024 12:51. Revision #12793

There is no power

- Ensure the AC power cord is connected securely.
- Ensure the plug is fully inserted into the wall socket and is switched on.
- Check fuse in the mains plug or adaptor.

There is no sound

- Make sure the unit is not in Standby mode.
- Check that the source component is properly connected.
- Check that your speakers are properly connected.
- Make sure the selected speaker A/B light corresponds to the speaker terminals that the loudspeakers are connected to.
- Make sure unit is not in mute mode.
- Check that the correct analogue or digital input button has been selected on the front panel. See the 'Front Panel Connections' section for more information.

There is no sound on one channel

- Check speaker connections.
- Check interconnects.

There is weak bass or diffused stereo imaging

- Ensure that speakers are not wired out of phase.

Speaker A/B and mute light flashing

- See section on CAP5 protection system.

The remote handset does not function

- Check that the batteries have not expired.
- Ensure that nothing is blocking the remote sensor.

There is no audio when connecting a Mac/PC to the USB audio input

- Ensure that all the steps within the 'USB Audio Connection' section of the manual have been followed.
- Ensure that the USB Audio source has been selected by selecting the Bluetooth/USB Audio button on the front panel. The USB Audio source is shown by the symbol being lit orange.
- Ensure that your PC/Mac is connected to the USB Audio input with a USB A to B cable.
- If you are connecting a PC and using the CXA in USB Audio Class 2, make sure that the correct USB driver is downloaded. The driver is available from www.cambridgeaudio.com/gbr/en/driver-updates.
- If you have downloaded a Cambridge Audio USB 2.0 Driver, ensure that the CXA is set to USB Audio Class 2 in the Setup Menu.

There is no audio when connecting a TV to the CXA

- The CXA is unable to decode a Dolby or Surround signal, ensure that the audio settings on your TV are set to PCM or Stereo.
- Ensure that your TV is connected to one of the SP/DIF or TOSLINK inputs on the CXA.

There are drop outs in audio when connected to a TV via Toslink

- Please see the 'Getting Connected' > 'Connecting a TV' section in the manual.

Technical specifications

Last updated: April 12, 2024 02:36. Revision #11904

CONTINUOUS POWER OUTPUT

CXA81/CXA81 Mk II: 80W RMS into 8 Ohms, 120W RMS into 4 Ohms
CXA61: 60W RMS into 8 Ohms, 90W RMS into 4 Ohms

DAC

CXA81 Mk II: ES9018K2M
CXA81: ES9016K2M
CXA61: ES9010K2M

THD (UNWEIGHTED)

<0.002% 1kHz at 80% of rated power
<0.02% 20Hz - 20kHz at 80% of rated power

FREQUENCY RESPONSE

<5Hz - 60kHz +/-1dB

S/N RATIO (REF 1W INTO 8 OHM)

>93 dB

S/N RATIO (REF FULL POWER)

>105 dB

INPUT SENSITIVITY

Input A1-A4 (unbalanced) 370mV RMS

INPUT IMPEDANCES

CXA81/CXA81 Mk II: Input A1 (balanced) 50 kOhm
Input A1-A4 (unbalanced) 43 kOhm

INPUTS

Balanced (*CXA81/CXA81 Mk II only*), Unbalanced, MP3 jack (*CXA61 only*), Coax SPDIF, TOSLINK, Bluetooth, USB Audio

OUTPUTS

Speakers, Headphone, Preamplifier Output, Sub Output

POWER AMP DAMPING FACTOR

>110 at 1kHz

USB AUDIO INPUT

USB Type B conforming to USB Audio Class 1 or USB Audio Class 2 (user selectable)

BLUETOOTH

4.2 A2DP/AVRCP supporting SBC, aptX and aptX HD codecs

COMPATIBILITY

USB Audio Class 1: Up to 24-bit 96kHz (asynchronous)
USB Audio Class 2: Up to 24-bit 384kHz (asynchronous) and up to DSD-256
TOSLINK: 16/24-bit 32-96kHz
Coax SPDIF: 16/24-bit 32-192kHz

MAX POWER CONSUMPTION

CXA81/CXA81 Mk II: 750W
CXA61: 600W

STANDBY POWER CONSUMPTION

<0.5W

DIMENSIONS

115 x 430 x 341mm (4.5 x 16.9 x 13.4")

WEIGHT

CXA81/CXA81 Mk II: 8.7kg (19.1lbs)
CXA61: 8.3kg (18.3lbs)

Frequently Asked Questions (FAQ)

Last updated: April 14, 2023 01:15. Revision #9177

How do I select the Balanced or Unbalanced inputs on the CXA81?

On the CXA81, pressing the A1 input selection button will toggle between the balanced and unbalanced inputs. The balanced input is shown by A1 being lit orange, while the unbalanced input is shown by A1 being lit blue.

Please ensure that the correct input is selected on the CXA, depending on how your CXA81 is connected. If the wrong input is selected, then there will be no sound from the amplifier.

Can I connect an external HDD to 'USB Audio In' on the CXA61/81?

No, there is no way to connect a USB drive or HDD directly to the CXA61/81 using its 'USB Audio' input. The 'USB Audio' input on the CXA61/81 will only support a direct connection with a PC or Mac. You will, however, be able to use one of our [network players](#) in combination with the CXA61/81 to do this.

How do I select the USB Audio input on the CXA61/81?

To select the USB Audio input on the CXA61/81, you will need to press the Bluetooth / USB Audio button found on the front of the unit twice.

- Press the button once to select the Bluetooth input, this will then turn Blue.
- Press the button once again to select the USB Audio input, which will then turn Orange.

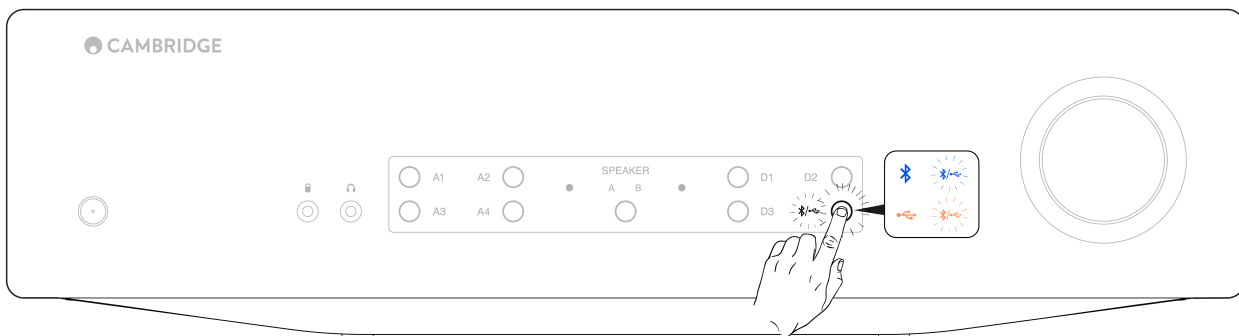

Alternatively, you can select this input using by using the USB Audio button on the CX remote.

Why can't I adjust the volume of the CXA61/81 with my mobile device when connected via Bluetooth?

When using Bluetooth with the CXA61/81, the amplifier's volume control takes over from the mobile devices' volume. The mobile device then produces a Bluetooth stream of fixed level volume, which is then adjusted at the amplifier's end.

It is normal behaviour for your mobile device not to be able to control the volume of the CXA61/81 when connected via Bluetooth. Volume adjustments can be made on the amplifier itself, using either the remote control or the front panel volume knob.

What is the crossover frequency on the CXA61/81?

The CXA61/81 has a low pass filter of 2.3 kHz applied at the Sub Out output. This is so that there is minimal phase added by the CXA at the Sub Out frequencies. This allows you to set your own crossover frequency on the Subwoofer itself.

What would the power output of the CXA be if I connect two pairs of speakers?

When you connect two pairs of speakers to an amplifier, the combined impedance is halved. So, when two pairs of 8Ω (Ohm) speakers are connected, the overall impedance becomes 4Ω, even though the individual impedance for each speaker remains unchanged at 8Ω.

The CXA61 has a power output of 60W RMS per channel into 8 Ohms, increasing to 90W RMS into 4Ω.

This quoted amplifier power rating is per channel. If you attach 2 pairs of 8Ω speakers, the overall impedance halves to 4Ω, so you'll be sending 90W per channel. This will then split between the two speakers attached to that channel, sending 45W to each speaker.

For the CXA81 the same as above will apply but as the CXA81 outputs 80W RMS which is increased to 120W at 4Ω. This means you will get 60W for each speaker when two pairs are used with the CXA81.

It is not recommended to connect 2 pairs of 4 Ohm or 6 Ohm speakers to the CXA61/81, as the impedance is halved meaning the impedance will be 2 Ohms or 3 Ohms respectively. This could result in the amplifier being driven too hard and CAP5 protection being activated, or damage being done to the amplifier and/or speakers.

Will the CXA61/81 playback 32-bit files via the USB Audio input?

Whilst the CXA's hardware is capable of handling 32-bit audio via the USB Audio input, the USB interface is reporting the host to be only 24-bit capable.

If you attempt to play 32-bit files, the USB driver will convert them to 24-bit by removing the least significant information.