

CORE 5x1 ILS

User Manual



CHAUVET **2**

Edition Notes

The CORE 5X1 ILS User Manual includes a description, safety precautions, installation, programming, operation, and maintenance instructions for the CORE 5X1 ILS as of the release date of this edition.

Trademarks

Chauvet, Chauvet DJ, the Chauvet logo, and CORE 5X1 ILS are registered trademarks or trademarks of Chauvet & Sons, LLC (d/b/a Chauvet and Chauvet Lighting) in the United States and other countries. Other company and product names and logos referred to herein may be trademarks of their respective companies.

Copyright Notice

The works of authorship contained in this manual, including, but not limited to, all designs, text, and images are owned by Chauvet.

© Copyright 2025 Chauvet & Sons, LLC. All rights reserved.

Electronically published by Chauvet in the United States of America.

Manual Use

Chauvet authorizes its customers to download and print this manual for professional information purposes only. Chauvet expressly prohibits the usage, copy, storage, distribution, modification, or printing of this manual or its content for any other purpose without written consent from Chauvet.

Document Printing

For best results, print this document in color, on letter size paper (8.5 x 11 in), double-sided. If using A4 paper (210 x 297 mm), configure the printer to scale the content accordingly.

Intended Audience

Any person installing, operating, and/or maintaining this product should completely read through the guide that shipped with the product, as well as this manual, before installing, operating, or maintaining this product.

Disclaimer

Chauvet believes that the information contained in this manual is accurate in all respects. However, Chauvet assumes no responsibility and specifically disclaims any and all liability to any party for any loss, damage, or disruption caused by any errors or omissions in this document, whether such errors or omissions result from negligence, accident, or any other cause. Chauvet reserves the right to revise the content of this document without any obligation to notify any person or company of such revision; however, Chauvet has no obligation to make, and does not commit to make, any such revisions.

Document Revision

Go to www.chauvetdj.com for the latest version.

| Revision | Date | Description |
|----------|---------|--------------------|
| 2 | 12/2025 | Updated DMX charts |

TABLE OF CONTENTS

| | |
|---|-----------|
| 1. Before You Begin | 1 |
| What Is Included | 1 |
| Unpacking Instructions | 1 |
| Claims | 1 |
| Text Conventions | 1 |
| Symbols | 1 |
| Safety Notes | 2 |
| RF Exposure Warning for North America and Australia | 2 |
| 2. Introduction | 3 |
| Product Overview | 3 |
| Product Dimensions | 4 |
| 3. Setup | 5 |
| AC Power | 5 |
| Fuse Replacement | 5 |
| Power Linking | 6 |
| Mounting | 7 |
| Orientation | 7 |
| Rigging | 7 |
| Connecting Units | 8 |
| Proper Usage | 9 |
| 4. Operation | 10 |
| Control Panel Operation | 10 |
| Menu Map | 10 |
| DMX Configuration | 11 |
| Starting Address | 11 |
| DMX Personalities | 11 |
| D-Fi USB Connectivity | 12 |
| D-Fi USB Compatibility | 12 |
| D-Fi USB Configuration | 12 |
| DMX Channel Assignments and Values | 13 |
| Zones for DMX Control | 13 |
| 9CH / 4CH | 13 |
| 22 CH | 14 |
| Standalone Configuration | 15 |
| Fixed Color | 15 |
| Automatic Program | 15 |
| Auto Program Speed | 15 |
| Auto Program Mode | 15 |
| Sound-Active Mode | 15 |
| Sound Sensitivity | 16 |
| Sound Lost Mode | 16 |
| Manual Color Mixing | 16 |
| Dimmer Mode | 16 |
| Back Light | 16 |
| Factory Reset | 16 |
| Wired Master/Slave Mode | 17 |
| D-Fi USB Master/Slave Mode | 17 |
| ILS Mode | 18 |
| RFC Remote Control | 18 |
| RFC Remote Binding | 18 |
| RFC Control Options | 18 |
| RFC Remote Control Operation | 19 |
| RFC-XL Remote Control Operation | 20 |

| | |
|--|----|
| 5. Maintenance | 21 |
| Product Maintenance | 21 |
| 6. Technical Specifications | 22 |
| Contact Us | 23 |
| Warranty & Returns..... | 23 |

1. Before You Begin

What Is Included

- CORE 5X1 ILS
- Power cable
- Quick Reference Guide

Unpacking Instructions

Carefully unpack the product immediately and check the container to make sure all the parts are in the package and are in good condition.

Claims





If the box or the contents (the product and included accessories) appear damaged from shipping, or show signs of mishandling, notify the carrier immediately, not Chauvet. Failure to report damage to the carrier immediately may invalidate a claim. In addition, keep the box and contents for inspection.

For other issues, such as missing components or parts, damage not related to shipping, or concealed damage, file a claim with Chauvet within 7 days of delivery.

Text Conventions

| Convention | Meaning |
|----------------------|--|
| 1–512 | A range of values |
| 50/60 | A set of values of which only one can be chosen |
| Settings | A menu option not to be modified |
| <ENTER> | A key to be pressed on the product’s control panel |
| ON | A value to be entered or selected |

Symbols

| Symbol | Meaning |
|---|---|
|  | Electrical warning. Not following these instructions may cause electrical damage to the product, accessories, or the user. |
|  | Critical installation, configuration, or operation information. Not following these instructions may make the product not work, cause damage to the product, or cause harm to the operator. |
|  | Important installation or configuration information. The product may not function correctly if this information is not used. |
|  | Useful information. |

Safety Notes

These Safety Notes include important information about installation, use, and maintenance of the CORE 5X1 ILS.



- **ALWAYS:**

- ◆ Connect to a grounded circuit.
- ◆ Connect to operating voltages as specified on the product's spec sticker.
- ◆ Disconnect from power before replacing the fuse.
- ◆ Disconnect from its power source during periods of inactivity.
- ◆ Use a safety cable when suspending overhead.
- ◆ Heed all restrictions and warnings on the spec sticker.
- ◆ Mount in a location with at least 20 in (50 cm) of ventilation.
- ◆ Replace the fuse with the same type and rating.

- In the event of a serious operating problem, stop using immediately..

- **DO NOT:**

- ◆ Open this product or attempt any repairs. It contains no user-serviceable parts.
- ◆ Look at the light source when the product is on.
- ◆ Use if the power cable is crimped or damaged.
- ◆ Disconnect by pulling on the power cable.
- ◆ Allow flammable materials close to the product when it is operating.
- ◆ Touch the housing when it is on.
- ◆ Block any ventilation holes/slots in the housing.
- ◆ Connect to a dimmer or rheostat.
- ◆ Carry the product by its power cable.
- ◆ Operate in temperatures higher than 104°F (40°C).
- ◆ Expose to environments that exceed the Ingress Protection (IP) rating.
- ◆ Expose to rain or moisture.
- ◆ Use outdoors.
- ◆ Submerge.



Keep this User Manual for future use. If the product is sold to someone else, be sure that they also receive this document.

RF Exposure Warning for North America and Australia

Warning! This equipment complies with FCC radiation exposure limits set forth for an uncontrolled environment. This equipment should be installed and operated with a minimum distance of 20 cm between the radiator and the user. This transmitter must not be co-located or operating in conjunction with any other antenna or transmitter.

2. Introduction

Product Overview

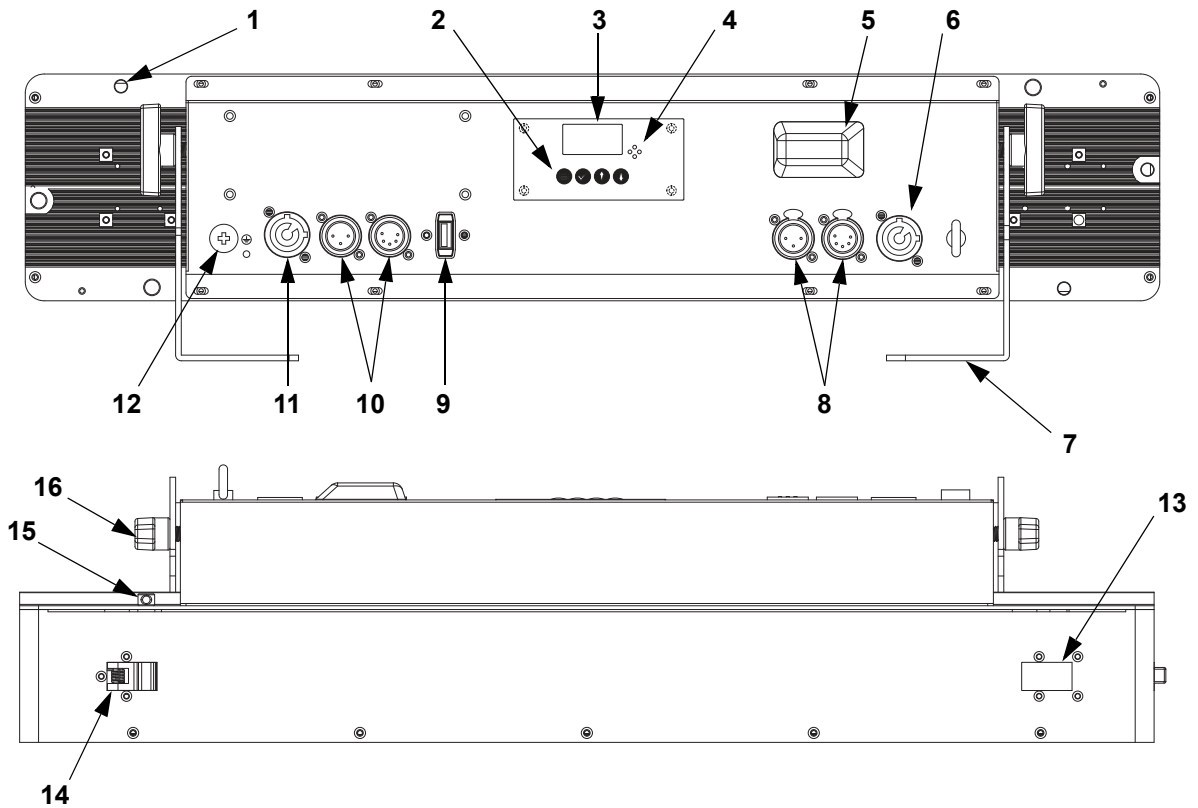

| # | Name | # | Name |
|---|---------------------------|----|-------------------------------|
| 1 | Locking pin hole (x6) | 9 | USB port |
| 2 | Menu buttons | 10 | DMX in (3-pin and 5-pin) |
| 3 | Menu display | 11 | Power in |
| 4 | Mic | 12 | Fuse holder |
| 5 | Antenna | 13 | Connecting hardware (female) |
| 6 | Power out | 14 | Connecting hardware (male) |
| 7 | Hanging brackets (x2) | 15 | Locking pins (x3) |
| 8 | DMX out (3-pin and 5-pin) | 16 | Bracket adjustment knobs (x2) |



WARNING! DO NOT plug anything other than a D-Fi USB into the USB type B port. Doing so may cause damage to the product.

Product Dimensions

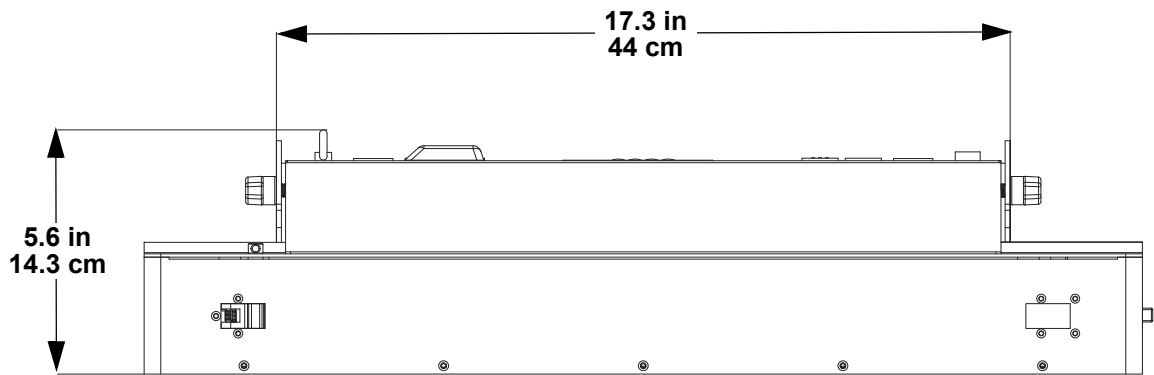
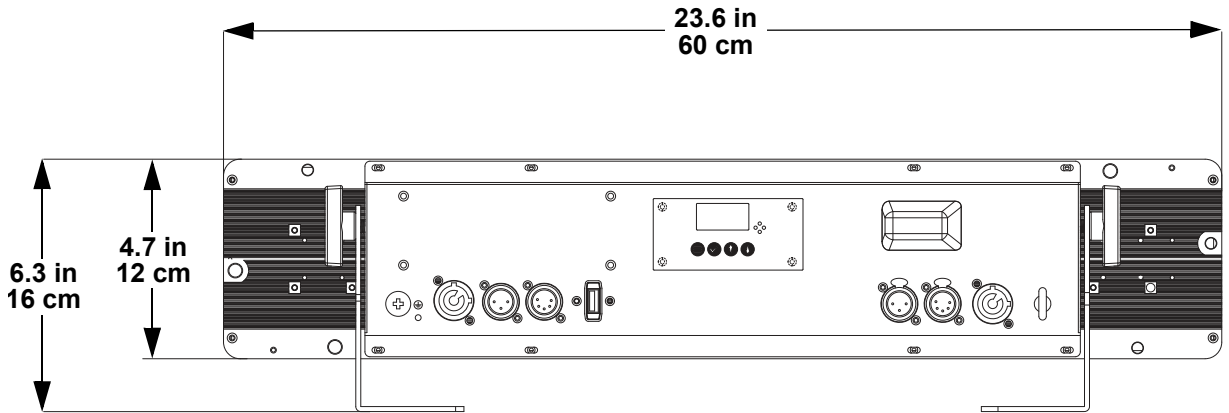

3. Setup

AC Power

The CORE 5X1 ILS has an auto-ranging power supply and it can work with an input voltage range of 100 to 240 VAC, 50/60 Hz.

To determine the product's power requirements (circuit breaker, power outlet, and wiring), use the current value listed on the label affixed to the product's back panel, or refer to the product's specifications chart. The listed current rating indicates the product's average current draw under normal conditions.



- **Always connect the product to a protected circuit (a circuit breaker or fuse). Make sure the product has an appropriate electrical ground to avoid the risk of electrocution or fire.**
- **To eliminate unnecessary wear and improve its lifespan, during periods of non-use completely disconnect the product from power via breaker or by unplugging it.**



- **Never connect the product to a rheostat (variable resistor) or dimmer circuit, even if the rheostat or dimmer channel serves only as a 0 to 100% switch.**

Fuse Replacement

1. Disconnect the product from power.
2. Using a Phillips-head screwdriver, unscrew the fuse holder and pull it straight out.
3. Remove the blown fuse from the holder and replace with a fuse of the exact same type and rating.
4. Re-insert the fuse holder and reconnect power.



Disconnect the product from the power outlet before replacing the fuse.



Always replace a blown fuse with one of the same type and rating.

Power Linking

This product provides power linking via the outlet located in the back of the product. See the diagram below for further explanation.

Power Linking Diagram

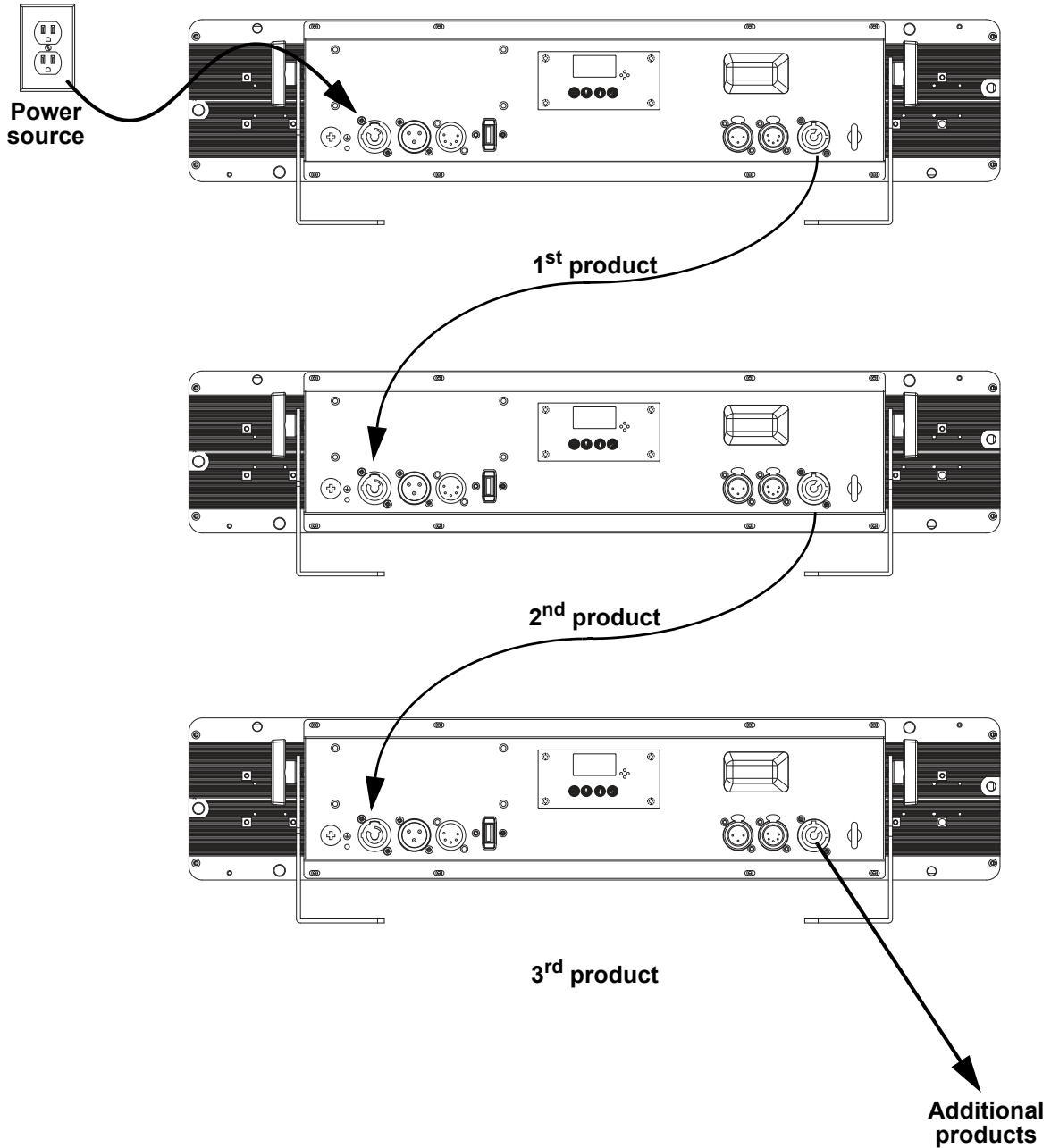

It is possible to link up to 6 CORE 5X1 ILS products on 120 VAC or up to 10 products on 230 VAC.



The power linking diagram shown above corresponds to the North American version of the product **ONLY!** If using the product in other markets, consult with the local Chauvet distributor as power linking connectors and requirements may differ by country or region.

Mounting

Before mounting the product, read and follow the safety recommendations indicated in the [Safety Notes](#).

Orientation

The CORE 5X1 ILS may be mounted in any position; however, make sure adequate ventilation is provided around the product.

Rigging

- Before deciding on a location for the product, always make sure there is easy access to the product for maintenance and programming.
- Make sure that the structure and attachment points can support the weight before hanging the product (see the [Technical Specifications](#) section for weight information).
- When mounting the product overhead, always use a safety cable. Mount the product securely to a rigging point, such as an elevated platform or a truss.
- When rigging the product onto a truss, use a mounting clamp of appropriate weight capacity. The bracket has a 13-mm hole, which is appropriate for this purpose.
- The bracket adjustment knobs allow for directional adjustment when aiming the product to the desired angle. Only loosen or tighten the bracket knobs manually. Using tools could damage the knobs.
- When power linking multiple products, mount the products close enough for power linking cables to reach.
- When mounting the product on the floor, make sure that the product and cables are away from people and vehicles.

Mounting Diagram

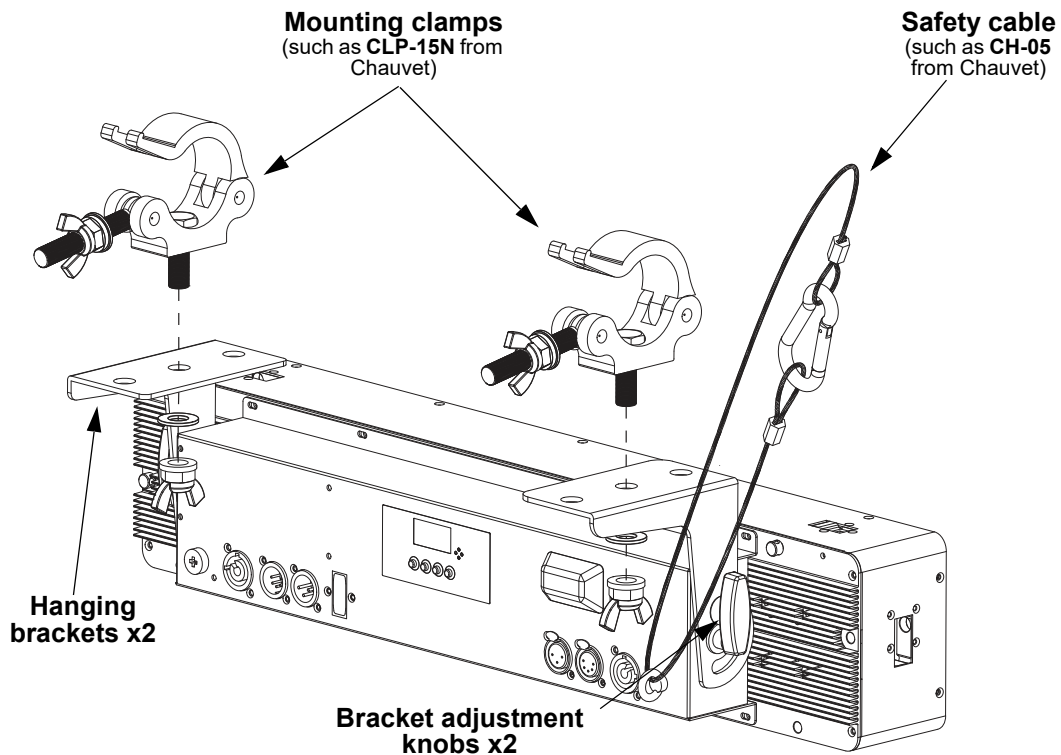

Connecting Units

Multiple CORE 5X1 ILS fixtures may be connected together using the built-in connecting hardware. To connect CORE 5x1 ILS fixtures:

1. Remove locking pins to release built-in male connecting hardware.

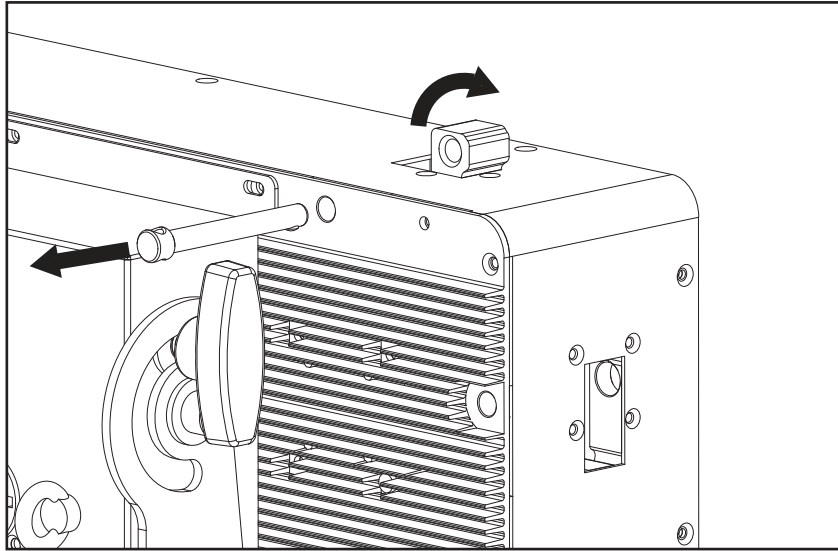

2. Position fixtures so that male connecting hardware is fitted into the female opening on the opposite fixture.

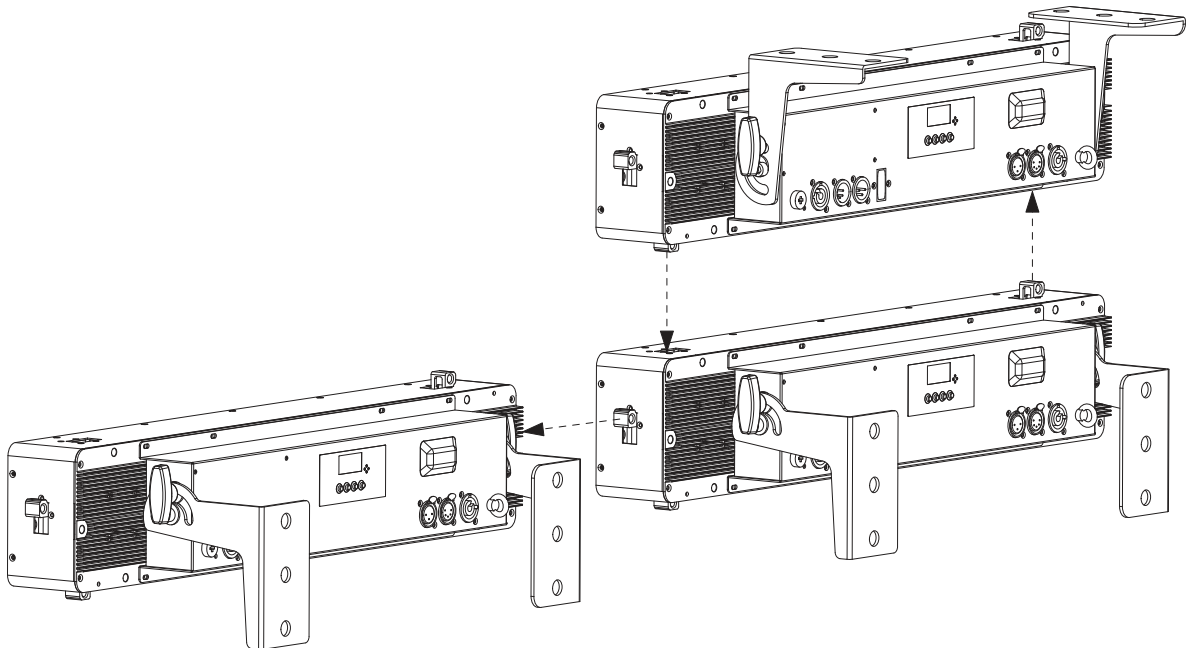

3. Replace locking pins so they pass through the locking pin holes and into the male connecting hardware of the attached fixture. Ensure that this is done for each connection point along adjoining fixtures.

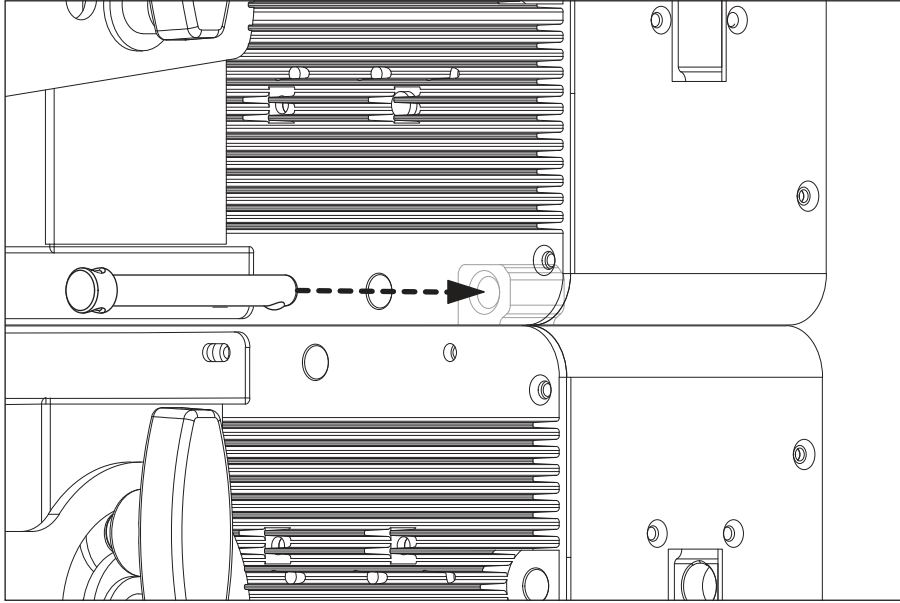





Proper Usage

This product is for overhead mounting only. For safety purposes, Chauvet recommends mounting lighting effect products on steady elevated platforms or sturdy overhead supports using suitable hanging clamps. In all cases, use safety cables. Obtain appropriate mounting hardware from a lighting vendor.

4. Operation

Control Panel Operation

To access the control panel functions, use the four buttons located underneath the display. Please refer to the [Product Overview](#) to see the button locations on the control panel.

| Button | Name | Function |
|---|---------|---|
|  | <Menu> | Press to find an operation mode or to back out of the current menu option |
|  | <Enter> | Press to activate a menu option or a selected value |
|  | <Up> | Press to scroll up the list of options or to find a higher value |
|  | <Down> | Press to scroll down the list of options or to find a lower value |

Menu Map

Refer to the CORE 5X1 ILS product page on www.chauvetdj.com for the latest menu map and software.

| Main Menu | Programming Levels | Description | |
|-------------|--------------------|---|--|
| DMX Address | d001–d509 | Selects DMX starting address | |
| DMX Mode | 4 CH | 4-channel DMX mode | |
| | 9 CH | 9-channel DMX mode | |
| | 22 CH | 22-channel DMX mode | |
| ILS Mode | ILS 1–2 | Sets ILS mode | |
| Slave | Slave | Sets fixture into slave mode | |
| Fixed Color | R | Selects a single static color or a combination of static colors | |
| | G | | |
| | B | | |
| | W | | |
| | RG | | |
| | RB | | |
| | RW | | |
| | GB | | |
| | GW | | |
| | BW | | |
| | RGB | | |
| | RGW | | |
| | RBW | | |
| GBW | | | |
| RBGW | | | |
| Auto | Program | 001–008 | Selects preset auto program |
| | Speed | 001–100 | Auto program speed, slow to fast |
| | Program Mode | Fade Snap | Selects the transition between auto programs |
| Sound | Sound | 001–008 | Selects preset sound-activated program |
| | Sensitivity | 001–100 | Sound sensitivity, low to high |
| | Sound Lost | Show | Reverts to auto program when sound is undetected |
| | | Freeze | Freezes last look when sound is undetected |
| | Black | Goes to blackout when sound is undetected | |

| Main Menu | Programming Levels | | Description |
|----------------------------|----------------------|----------------|--|
| Manual Color | Red | 000–255 | Custom static colors Combine red, green, blue, and white |
| | Green | 000–255 | |
| | Blue | 000–255 | |
| | White | 000–255 | |
| Dimmer Mode | OFF | | Turns off dimmer |
| | Dimmer Fast | | Sets dimmer speed |
| | Dimmer Medium | | |
| | Dimmer Slow | | |
| RF Remote | RF Mode | OFF | Turns off RF |
| | | Public | Enables control of fixture using any RF remote |
| | | Bind | Enables control of fixture using only paired RF remote |
| | RF Binding | FFFF | Turns off RF binding |
| | | * | Fixture ready to bind with RF remote |
| RF Group | 1–4 | Sets RF Group | |
| Back Light | 10S | | Sets the amount of time before display back light turns off after period of inactivity |
| | 30S | | |
| | 2 Min | | |
| | Always On | | |
| Fixture Information | Version | | Displays firmware version |
| | Running | | Displays current operating mode |
| | DMX Address | | Displays current set DMX address |
| Factory Reset | No | | Reset product to factory default settings |
| | Yes | | |
| Firmware Update | No | | Enables or disables automatic firmware update from USB |
| | Yes | | |

DMX Configuration

The CORE 5X1 ILS works with a DMX controller. Information about DMX is in the Chauvet DMX Primer, which is available from the Chauvet website.

Starting Address

The CORE 5X1 ILS uses up to 22 DMX channels, which defines the highest recommended address to **491**.

When selecting a starting DMX address, always consider the number of DMX channels the DMX mode uses. If the starting address is set too high, access to some channels could be restricted.

For information about the DMX protocol, download the DMX Primer from www.chauvetdj.com.

To select the starting address, do the following:

1. Press **<MENU>**.
2. Use **<UP>** or **<DOWN>** to select **DMX Address**.
3. Press **<ENTER>**.
4. Use **<UP>** or **<DOWN>** to select the starting address, from **001–509**.
5. Press **<ENTER>**.

DMX Personalities

The CORE 5X1 ILS has **3** DMX personalities: **4CH**, **9CH**, and **22CH**.

To select which DMX personality to use, follow the steps below:

1. Press **<MENU>**.
2. Use **<UP>** or **<DOWN>** to select **DMX Mode**.
3. Press **<ENTER>**.
4. Use **<UP>** or **<DOWN>** to select **4CH**, **9CH**, or **22CH**.
5. Press **<ENTER>**.

D-Fi USB Connectivity

The CORE 5X1 ILS is able to become a D-Fi wireless receiver/transmitter with the use of the D-Fi USB from Chauvet DJ. Simply set the product's DMX Personality and DMX Address, set the DIP switch D-Fi receiving/transmitting channel, then plug it into the D-Fi USB port.



WARNING! DO NOT plug anything other than a D-Fi USB into the USB type B port. Doing so may cause damage to the product.



Once plugged in, the D-Fi USB will take over the product. Wired DMX and manual display control / menu buttons will be unavailable until the D-Fi USB is unplugged. The priority levels are:

1. D-Fi USB
2. Wired DMX
3. Manual Digital Display/Menu Buttons

D-Fi USB Compatibility

The D-Fi USB can receive a DMX signal from the D-Fi Hub and the FlareCON Air 2 as well as other D-Fi USB products.

D-Fi USB Configuration

1. Set the DMX Personality and DMX address on the CORE 5X1 ILS.
2. Use the Chart provided to set **BOTH**:
 - the Channel, and then
 - The Receiving or Transmitting option

NOTE: DIP Switch 5 is for Transmitting OR Receiving, please choose carefully.

D-Fi USB DIP Switch Channels

| Receiving | | | | | | Receiving | | | | | | Transmitting | | | | | | Transmitting | | | | | |
|-----------|---|---|---|---|-----|-----------|---|---|---|---|-----|--------------|---|---|---|---|-----|--------------|---|---|---|---|-----|
| Ch. | 1 | 2 | 3 | 4 | T/R | Ch. | 1 | 2 | 3 | 4 | T/R | Ch. | 1 | 2 | 3 | 4 | T/R | Ch. | 1 | 2 | 3 | 4 | T/R |
| 1 | █ | █ | █ | █ | █ | 9 | █ | █ | █ | █ | █ | 1 | █ | █ | █ | █ | █ | 9 | █ | █ | █ | █ | █ |
| 2 | █ | █ | █ | █ | █ | 10 | █ | █ | █ | █ | █ | 2 | █ | █ | █ | █ | █ | 10 | █ | █ | █ | █ | █ |
| 3 | █ | █ | █ | █ | █ | 11 | █ | █ | █ | █ | █ | 3 | █ | █ | █ | █ | █ | 11 | █ | █ | █ | █ | █ |
| 4 | █ | █ | █ | █ | █ | 12 | █ | █ | █ | █ | █ | 4 | █ | █ | █ | █ | █ | 12 | █ | █ | █ | █ | █ |
| 5 | █ | █ | █ | █ | █ | 13 | █ | █ | █ | █ | █ | 5 | █ | █ | █ | █ | █ | 13 | █ | █ | █ | █ | █ |
| 6 | █ | █ | █ | █ | █ | 14 | █ | █ | █ | █ | █ | 6 | █ | █ | █ | █ | █ | 14 | █ | █ | █ | █ | █ |
| 7 | █ | █ | █ | █ | █ | 15 | █ | █ | █ | █ | █ | 7 | █ | █ | █ | █ | █ | 15 | █ | █ | █ | █ | █ |
| 8 | █ | █ | █ | █ | █ | 16 | █ | █ | █ | █ | █ | 8 | █ | █ | █ | █ | █ | 16 | █ | █ | █ | █ | █ |

DMX Channel Assignments and Values

Zones for DMX Control

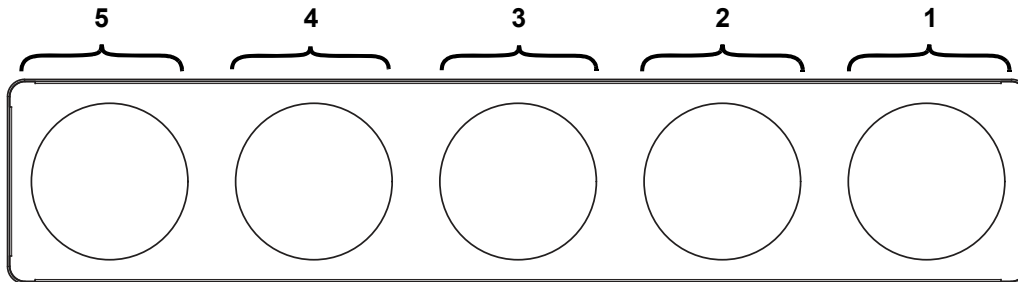

9CH / 4CH

| 4CH | 9CH | Function | Value | Percent/Setting |
|-----|-----|-------------------|-----------|----------------------------------|
| - | 1 | Dimmer | 000 ⇔ 255 | 0-100% |
| 1 | 2 | Red | 000 ⇔ 255 | 0-100% |
| 2 | 3 | Green | 000 ⇔ 255 | 0-100% |
| 3 | 4 | Blue | 000 ⇔ 255 | 0-100% |
| 4 | 5 | White | 000 ⇔ 255 | 0-100% |
| - | 6 | Strobe | 000 ⇔ 010 | No function |
| | | | 011 ⇔ 255 | Strobe, slow to fast |
| - | 7 | Auto Programs | 000 ⇔ 010 | No function |
| | | | 011 ⇔ 037 | Auto program 1 |
| | | | 038 ⇔ 064 | Auto program 2 |
| | | | 065 ⇔ 091 | Auto program 3 |
| | | | 092 ⇔ 118 | Auto program 4 |
| | | | 119 ⇔ 145 | Auto program 5 |
| | | | 146 ⇔ 172 | Auto program 6 |
| | | | 173 ⇔ 199 | Auto program 7 |
| | | | 200 ⇔ 226 | Auto program 8 |
| | | | 227 ⇔ 255 | Auto program 9 |
| - | 8 | Auto Speed | 000 ⇔ 255 | Auto program speed, slow to fast |
| - | 9 | Dimmer Speed Mode | 000 ⇔ 051 | Dimmer speed set from display |
| | | | 052 ⇔ 101 | Dimmer speed mode off |
| | | | 102 ⇔ 152 | Dimmer speed mode fast (DIM1) |
| | | | 153 ⇔ 203 | Dimmer speed mode medium (DIM2) |
| | | | 204 ⇔ 255 | Dimmer speed mode slow (DIM3) |

22 CH

| 22CH | Function | Value | Percent/Setting |
|------|----------|-----------|----------------------|
| 1 | Dimmer | 000 ⇔ 255 | 0–100% |
| 2 | Red 1 | 000 ⇔ 255 | 0–100% |
| 3 | Green 1 | 000 ⇔ 255 | 0–100% |
| 4 | Blue 1 | 000 ⇔ 255 | 0–100% |
| 5 | White 1 | 000 ⇔ 255 | 0–100% |
| 6 | Red 2 | 000 ⇔ 255 | 0–100% |
| 7 | Green 2 | 000 ⇔ 255 | 0–100% |
| 8 | Blue 2 | 000 ⇔ 255 | 0–100% |
| 9 | White 2 | 000 ⇔ 255 | 0–100% |
| 10 | Red 3 | 000 ⇔ 255 | 0–100% |
| 11 | Green 3 | 000 ⇔ 255 | 0–100% |
| 12 | Blue 3 | 000 ⇔ 255 | 0–100% |
| 13 | White 3 | 000 ⇔ 255 | 0–100% |
| 14 | Red 4 | 000 ⇔ 255 | 0–100% |
| 15 | Green 4 | 000 ⇔ 255 | 0–100% |
| 16 | Blue 4 | 000 ⇔ 255 | 0–100% |
| 17 | White 4 | 000 ⇔ 255 | 0–100% |
| 18 | Red 5 | 000 ⇔ 255 | 0–100% |
| 19 | Green 5 | 000 ⇔ 255 | 0–100% |
| 20 | Blue 5 | 000 ⇔ 255 | 0–100% |
| 21 | White 5 | 000 ⇔ 255 | 0–100% |
| 22 | Strobe | 000 ⇔ 010 | No function |
| | | 011 ⇔ 255 | Strobe, slow to fast |

Standalone Configuration

Set the product in one of the standalone modes to operate without a DMX controller.



Never connect a product that is operating in any standalone mode to a DMX string connected to a DMX controller. Products in standalone mode may transmit DMX signals that could interfere with the DMX signals from the controller.

Fixed Color

To operate the CORE 5X1 ILS using a static color:

1. Press **<MENU>**.
2. Use **<UP>** or **<DOWN>** to select **Fixed Color**.
3. Press **<ENTER>**.
4. Use **<UP>** or **<DOWN>** to select the desired static color.
5. Press **<ENTER>**.

Automatic Program

To operate the CORE 5X1 ILS using an automatic program:

1. Press **<MENU>**.
2. Use **<UP>** or **<DOWN>** to select **Auto**.
3. Press **<ENTER>**.
4. Use **<UP>** or **<DOWN>** to select **Program**.
5. Press **<ENTER>**.
6. Use **<UP>** or **<DOWN>** to select an automatic program, from **001–008**.
7. Press **<ENTER>**.

Auto Program Speed

To adjust the speed of an automatic program on the CORE 5X1 ILS:

1. Press **<MENU>**.
2. Use **<UP>** or **<DOWN>** to select **Auto**.
3. Press **<ENTER>**.
1. Use **<UP>** or **<DOWN>** to select **Speed**.
2. Press **<ENTER>**.
3. Use **<UP>** or **<DOWN>** to increase or decrease the speed, from **001–100**.
4. Press **<ENTER>**.

Auto Program Mode

To adjust the transitions between automatic programs on the CORE 5X1 ILS:

1. Press **<MENU>**.
2. Use **<UP>** or **<DOWN>** to select **Auto**.
3. Press **<ENTER>**.
1. Use **<UP>** or **<DOWN>** to select **Program Mode**.
2. Press **<ENTER>**.
3. Use **<UP>** or **<DOWN>** to select between **Fade** or **Snap**.
4. Press **<ENTER>**.

Sound-Active Mode

To operate the CORE 5X1 ILS using a sound-active program:

1. Press **<MENU>**.
2. Use **<UP>** or **<DOWN>** to select **Sound**.
3. Press **<ENTER>**.
1. Use **<UP>** or **<DOWN>** to select **Sound**.
2. Press **<ENTER>**.
3. Use **<UP>** or **<DOWN>** to select a sound-active program, from **001–008**.
4. Press **<ENTER>**.

Sound Sensitivity

To set the sound sensitivity of the product, do the following:

1. Press **<MENU>**.
2. Use **<UP>** or **<DOWN>** to select **Sound**.
3. Press **<ENTER>**.
1. Use **<UP>** or **<DOWN>** to select **Sensitivity**.
2. Press **<ENTER>**.
3. Use **<UP>** or **<DOWN>** to increase or decrease the sound sensitivity, from **001–100**.
4. Press **<ENTER>**.



The product will only respond to low frequencies of music (bass and drums).

Sound Lost Mode

To set the sound sensitivity of the product, do the following:

1. Press **<MENU>**.
2. Use **<UP>** or **<DOWN>** to select **Sound**.
3. Press **<ENTER>**.
4. Use **<UP>** or **<DOWN>** to select **Sound Lost**.
5. Press **<ENTER>**.
6. Use **<UP>** or **<DOWN>** to select from **Show**, **Freeze**, or **Blackout**.
7. Press **<ENTER>**.

Manual Color Mixing

To operate the CORE 5X1 ILS using a custom static color:

1. Press **<MENU>**.
2. Use **<UP>** or **<DOWN>** to select **Manual Color**.
3. Press **<ENTER>**.
4. Use **<UP>** or **<DOWN>** to select between **Red**, **Green**, **Blue**, and **White**.
5. Press **<ENTER>**.
6. Use **<UP>** or **<DOWN>** to increase or decrease the selected value from **000–255**.
7. Repeat steps 4-6 until the product output is set as desired.

Dimmer Mode

To set the dimmer value on the CORE 5X1 ILS:

1. Press **<MENU>**.
2. Use **<UP>** or **<DOWN>** to select **Dimmer Mode**.
3. Press **<ENTER>**.
4. Use **<UP>** or **<DOWN>** to set dimmer speed to **Off**, **Dimmer Fast**, **Dimmer Medium**, or **Dimmer Slow**.
5. Press **<ENTER>**.

Back Light

To set the amount of time before the back light on the CORE 5X1 ILS turns off after a period of inactivity:

1. Press **<MENU>**.
2. Use **<UP>** or **<DOWN>** to select **Back Light**.
3. Press **<ENTER>**.
4. Use **<UP>** or **<DOWN>** to set back light time out to **10S**, **30S**, **2Min**, or **Always On**.
5. Press **<ENTER>**.

Factory Reset

To return the CORE 5X1 ILS to factory default settings:

1. Press **<MENU>**.
2. Use **<UP>** or **<DOWN>** to select **Factory Reset**.
3. Press **<ENTER>**.
4. Use **<UP>** or **<DOWN>** to select **Yes**.
5. Press **<ENTER>**.

Wired Master/Slave Mode

The Master/Slave mode allows a single CORE 5X1 ILS product (the “master”) to control the actions of one or more CORE 5X1 ILS products (the “slaves”) without the need of a DMX controller. The master product will be set to operate in either standalone mode or with the IRC-6, while the slave products will be set to operate in slave mode. Once set and connected, the slave products will operate in unison with the master product.

Configure the products as indicated below.

Slave products:

1. Set each slave product to the same starting DMX address.
1. Press **<MENU>**.
2. Use **<UP>** or **<DOWN>** to select **Slave**.
3. Press **<ENTER>** twice.
4. Connect the DMX input of the first slave product to the DMX output of the master product.
5. Connect the DMX input of the subsequent slave products to the DMX output of the previous slave product.
6. Finish setting and connecting all the slave products.

Master product:

1. Set the master product to operate in **Fixed Color, Auto, Sound, or Manual Color** standalone mode.
2. Make the master product the first product in the DMX daisy chain.



- **Configure all the slave products before connecting the master to the daisy chain.**
- **Never connect a DMX controller to a DMX string configured for Master/Slave operation because the controller may interfere with the signals from the master.**
- **Do not connect more than 31 slaves to the master.**

D-Fi USB Master/Slave Mode

The D-Fi USB allows a single CORE 5X1 ILS product (the “master”) to control the actions of one or more CORE 5X1 ILS products (the “slaves”) without the need of a DMX controller or DMX cables. The master (transmitter) product will be set to operate in standalone mode, while the slave (receiver) products will be set to operate in slave mode. Once set and connected, the slave products will operate in unison with the master product.

Configure the products as indicated below:

Slave products:

1. Press **<MENU>**.
2. Use **<UP>** or **<DOWN>** to select **Slave**.
3. Press **<ENTER>** twice.
4. Plug in the D-Fi USB.
5. Set the D-Fi USB to receive on a specific channel, 1–16.
6. Finish setting and connecting all the slave products.

Master product:

1. Set the master product to operate in **Fixed Color, Auto, Sound, or Manual Color** standalone mode.
2. Plug in the D-Fi USB.
3. Set the D-Fi USB to transmit on the D-Fi channel the slaves are receiving on.



- **All products must be set to the same DMX personality, DMX address, and D-Fi channel.**
- **Configure all the slave products before configuring the master to transmit.**
- **Never connect a DMX controller to a D-Fi channel configured for Master/Slave operation because the controller may interfere with the signals from the master.**

ILS Mode

ILS (Integrated Lighting System) provides 2 modes that synchronize with the GigBAR MOVE+ILS: Mode 1 synchronizes with side 1 of the GigBAR MOVE+ILS, whereas mode 2 synchronizes with side 2 of the GigBAR MOVE+ILS. When linked, effects will sync with the most similar effect on the selected side of the GigBAR MOVE+ILS: Kinta effects will sync with one of the kintas, moving heads will sync with one of the moving heads, and wash effects will sync with one of the pars. Laser effects will sync with the laser, and strobe effects will sync with the strobe effects regardless of ILS mode.

This product will synchronize with the par effect on the selected side of the GigBAR MOVE+ILS, as well as the strobes.

To set the CORE 5X1 ILS to respond to an ILS signal:

1. Press **<MENU>**.
2. Use **<UP>** or **<DOWN>** to select **ILS Mode**.
3. Press **<ENTER>**.
4. Use **<UP>** or **<DOWN>** to select from **ILS1** (side 1) or **ILS2** (side 2)
5. Press **<ENTER>**.

RFC Remote Control

The CORE 5X1 ILS can be operated with an RFC remote or an RFC-XL remote (sold separately).



For more information about using an RFC or RFC-XL remote, download the user manuals from www.chauvetdj.com

RFC Remote Binding

To enable RF control, the product must bind to the RFC/RFC-XL. To bind the CORE 5X1 ILS to an RFC/RFC-XL:

1. Press **<MENU>**.
2. Use **<UP>** or **<DOWN>** to select **RF Remote**.
3. Press **<ENTER>**.
4. Use **<UP>** or **<DOWN>** to select **RF Mode**.
5. Press **<ENTER>**.
6. Use **<UP>** or **<DOWN>** to select **Bind**.
7. Press **<ENTER>**.
8. Use **<UP>** or **<DOWN>** to select **RF Binding**.
9. Press **<ENTER>**.
10. Use **<UP>** or **<DOWN>** to select *****.
11. Press **<ENTER>** and wait until ***** begins moving from left to right.
12. Press and hold **<BLACK OUT>** on the RFC/RFC-XL until it binds to the fixture.

RFC Control Options

The RFC-XL can control multiple products at once, whether in defined groups or in public mode. To set the CORE 5X1 ILS to public RFC/RFC-XL control or to an RFC-XL group:

1. Press **<MENU>**.
2. Use **<UP>** or **<DOWN>** to select **RF Remote**.
3. Press **<ENTER>**.
4. Use **<UP>** or **<DOWN>** to select **RF Mode**.
5. Press **<ENTER>**.
6. Use **<UP>** or **<DOWN>** to select **Public**.
7. Press **<ENTER>**.
8. Use **<UP>** or **<DOWN>** to select to control mode, from **1–4** (group 1–4).
9. Press **<ENTER>**.

RFC Remote Control Operation

| RFC | Button | Function |
|-----|----------------|---|
| | <BLACK OUT> | Press to turn off all lights until the button is pressed again |
| | <STROBE> | Press to toggle strobe, then use <+> or <-> to increase or decrease strobe speed |
| | <DIMMER> | Press then use <+> or <-> to increase or decrease the dimmer |
| | <AUTO> | Press to activate automatic mode, then use <+> or <-> to select a program |
| | <SPD/SENS> | Press then use <+> or <-> to increase or decrease speed or sensitivity |
| | <SOUND> | Press to activate sound-active mode, then use <+> or <-> to select a program |
| | <-> | Press to decrease speed, sensitivity, or the dimmer/color value, or to scroll down the list of programs |
| | <+> | Press to increase speed, sensitivity, or the dimmer/color value, or to scroll up the list of programs |
| | <FREEZE> | Press to stop all movement and color chasing |
| | <R> | In manual mode, press then use <+> or <-> to increase or decrease the red value |
| | <G> | In manual mode, press then use <+> or <-> to increase or decrease the green value |
| | | In manual mode, press then use <+> or <-> to increase or decrease the blue value |
| | <W> | In manual mode, press then use <+> or <-> to increase or decrease the UV value |
| | <FADE/SNAP> | Press to toggle between fade and snap programs |
| | <MANUAL> | Press to activate manual mode |
| | <PRESET/COLOR> | Press to activate presets/colors, then use <+> or <-> to select a preset/color |



The RFC remote will not respond to any inputs when Freeze or Black Out is activated. If the remote does not respond when a button is pressed, try pressing <FREEZE> or <BLACK OUT>. Freeze or Black Out may have been inadvertently activated.

RFC-XL Remote Control Operation

| RFC | Button | Function |
|-----|----------------------|---|
| | <ON/OFF> | Press to power the RFC-XL on or off |
| | Color picker | Use to select a color (does not correspond to colors printed on remote) |
| | <GROUP> | Press to cycle between groups 1–4 and public mode |
| | <BLACK OUT> | Press to turn off all lights until the button is pressed again |
| | <AUTO> | Press to activate automatic mode, then use <^> or <v> to select a program |
| | <FADE> | Press to toggle between fade and snap programs |
| | <SOUND> | Press to activate sound-active mode, then use <^> or <v> to select a program |
| | <SPEED/ SENSITIVITY> | Press then use <^> or <v> to increase or decrease speed or sensitivity |
| | <^> | Press to increase the selected value, or to scroll up the list of options |
| | <v> | Press to decrease the selected value, or to scroll down the list of options |
| | <STROBE> | Press to toggle strobe, then use <^> or <v> to increase or decrease strobe speed |
| | <DIMMER> | Press then use <^> or <v> to increase or decrease the dimmer |
| | <RED> | In manual mode, press then use <^> or <v> to increase or decrease the red value |
| | <GREEN> | In manual mode, press then use <^> or <v> to increase or decrease the green value |
| | <BLUE> | In manual mode, press then use <^> or <v> to increase or decrease the blue value |
| | <WHITE> | In manual mode, press then use <^> or <v> to increase or decrease the white value |
| | <COLOR> | Press to activate colors, then use <^> or <v> or the color picker to select a color |
| | <FREEZE> | Press to stop all movement and color chasing |



The RFC-XL remote will not respond to any inputs when Black Out is activated. If the remote does not respond when a button is pressed, try pressing <BLACK OUT>. You may have inadvertently activated Black Out.

5. Maintenance

Product Maintenance

Dust build-up reduces light output performance and can cause overheating. This can lead to reduction of the light source's life and/or mechanical wear. To maintain optimum performance and minimize wear, clean all lighting products at least twice a month. However, be aware that usage and environmental conditions could be contributing factors to increase the cleaning frequency.

To clean the product, follow the instructions below:

1. Unplug the product from power.
2. Wait until the product is at room temperature.
3. Use a vacuum (or dry compressed air) and a soft brush to remove dust collected on the external surface/vents.
4. Clean all transparent surfaces with a mild soap solution, ammonia-free glass cleaner, or isopropyl alcohol.
5. Apply the solution directly to a soft, lint free cotton cloth or a lens cleaning tissue.
6. Softly drag any dirt or grime to the outside of the transparent surface.
7. Gently polish the transparent surfaces until they are free of haze and lint.



Always dry the transparent surfaces carefully after cleaning them.

6. Technical Specifications

Dimensions and Weight

| Length | Width | Height | Weight |
|-----------------|------------------|----------------|--------------|
| 23.6 in (60 cm) | 5.6 in (14.3 cm) | 6.3 in (16 cm) | 11 lb (5 kg) |

Note: Dimensions in inches are rounded.

Power

| Power Supply Type | Range | Voltage Selection |
|----------------------|--------------------------|-------------------|
| Switching (internal) | 100 to 240 VAC, 50/60 Hz | Auto-ranging |

| Parameter | 120 V, 60 Hz | 230 V, 50 Hz |
|----------------------------------|------------------|-------------------|
| Consumption | 120 W | 113 W |
| Operating Current | 1.8 A | 1.13 A |
| Power linking current (products) | 8 A (6 products) | 8 A (10 products) |
| Fuse | T3.5LA, 250 V | T3.5LA, 250 V |

| Power I/O | U.S./Worldwide | UK/Europe |
|------------------------|---------------------|---------------------|
| Power input connector | powerCon compatible | powerCon compatible |
| Power output connector | powerCon compatible | powerCon compatible |
| Power cable plug | Edison (U.S.) | Local Plug |

Light Source

| Type | Color | Quantity | Power | Current | Lifespan |
|------|--------|----------|-------|---------|--------------|
| LED | RGB+WW | 5 | 35W | 1.2A | 50,000 hours |

Photometrics

| Strobe Rate | Beam Angle | Field Angle | Illuminance @ 2 m | Lumens |
|-------------|------------|-------------|-------------------|-----------|
| 0 to 20 Hz | 54° | 75° | 953 lux | 2,875 lux |

Thermal

| Maximum External Temperature | Cooling System |
|------------------------------|----------------|
| 104 °F (40 °C) | Convection |

DMX

| I/O Connector | Channel Range |
|---------------------|---------------|
| 3-pin and 5-pin XLR | 4, 9, or 22 |

Ordering

| Product Name | Item Code | UPC Number |
|--------------|-----------|--------------|
| CORE 5X1 ILS | 10032676 | 781462230241 |



Contact Us

| General Information | Technical Support |
|---|--|
| Chauvet World Headquarters | |
| Address: 3360 Davie Rd., Suite 509 Davie, FL 33314 Voice: (954) 577-4455 Fax: (954) 929-5560 Toll Free: (800) 762-1084 | Voice: (844) 393-7575 Fax: (954) 756-8015 Email: chauvetcs@chauvetlighting.com Website: www.chauvetdj.com |
| Chauvet U.K. | |
| Address: Pod 1 EVO Park Little Oak Drive, Sherwood Park Nottinghamshire, NG15 0EB UK Voice: +44 (0) 1773 511115 Fax: +44 (0) 1773 511110 | Email: UKtech@chauvetlighting.eu Website: www.chauvetdj.eu |
| Chauvet Benelux | |
| Address: Vaartlaan 9 9800 Deinze Belgium Voice: +32 9 388 93 97 | Email: BNLtech@chauvetlighting.eu Website: www.chauvetdj.eu |
| Chauvet France | |
| Address: 3, Rue Ampère 91380 Chilly-Mazarin France Voice: +33 1 78 85 33 59 | Email: FRtech@chauvetlighting.fr Website: www.chauvetdj.eu |
| Chauvet Germany | |
| Address: Bruno-Bürgel-Str. 11 28759 Bremen Germany Voice: +49 421 62 60 20 | Email: DEtech@chauvetlighting.de Website: www.chauvetdj.eu |
| Chauvet Mexico | |
| Address: Av. de las Partidas 34 - 3B (Entrance by Calle 2) Zona Industrial Lerma Lerma, Edo. de México, CP 52000 Voice: +52 (728) 690-2010 | Email: servicio@chauvet.com.mx Website: www.chauvetdj.mx |

Warranty & Returns

For warranty terms and conditions and return information, please visit our website.

For customers in the United States and Mexico: www.chauvetlighting.com/warranty-registration.

For customers in the United Kingdom, Republic of Ireland, Belgium, the Netherlands, Luxembourg, France, and Germany: www.chauvetlighting.eu/warranty-registration.