



TMD16
16 CH DIGITAL MIXER

User Guide

INTRODUCTION.....	3	EQ	20
Box Contents	3	Compressor	21
Support.....	3	Onboard Effects.....	22
Important Safety Precautions.....	3	Effects List.....	23
Sound Level	3	Connecting to a Bluetooth® Device	24
SETUP.....	4	System Screen	25
Connection Diagram.....	4	Preset Menu	25
USB Setup.....	5	Password Protection	27
Common Setup Scenarios	6	Firmware	27
Live Sound	6	Factory Reset.....	28
Recording.....	7	TROUBLESHOOTING	29
FEATURES	8	APPENDIX	31
Top Panel	8	Technical Specifications	31
Rear Panel.....	12	Trademarks & Licenses	32
Main Meters.....	14		
OPERATION	15		
Encoder Knobs and Function Buttons	15		
Selecting a Channel and Adjusting Settings.....	16		
Channels	17		
Soloing a Channel	18		
Muting a Channel	19		
Output Select	19		

Thank you for purchasing the TMD16 digital mixer for live sound, streaming, studio work, and more. Its compact footprint and simple control surface make it easy to use for advanced audio engineers and beginners. At Alto Professional, performance and reliability mean as much to us as they do to you. We design our equipment with only one thing in mind—to make your performance the best it can be.

Box Contents

- TMD16
- Power Cable (6 ft. / 183 cm)
- USB Cable (3 ft. / 91 cm)
- Quickstart Guide
- Safety & Warranty Manual

Support

For the latest information about this product (system requirements, compatibility information, etc.) and product registration, visit altoprofessional.com.

For additional product support, visit support.altoprofessional.com

Important Safety Precautions

Please note: Alto Professional and inMusic are not responsible for the use of its products or the misuse of this information for any purpose. Alto Professional and inMusic are not responsible for the misuse of its products caused by avoiding compliance with inspection and maintenance procedures. Please also refer to the included safety and warranty manual for more information.

Sound Level

Permanent hearing loss may be caused by exposure to extremely high noise levels. The U.S. Occupational Safety and Health Administration (OSHA) has specified permissible exposures to certain noise levels. According to OSHA, exposure to high sound pressure levels (SPL) in excess of these limits may result in hearing loss. When using equipment capable of generating high SPL, use hearing protection while such equipment is under operation.

Hours per day	SPL (dB)	Example
8	90	Small gig
6	92	Train
4	95	Subway train
3	97	High-level desktop monitors
2	100	Classical music concert
1.5	102	Riveting machine
1	105	Machine factory
0.5	110	Airport
0.25 or less	115	Rock concert

Connection Diagram

Items not listed under [Introduction > Box Contents](#) are sold separately.

See the connector examples below for using XLR or 1/4" (6.35 mm) wiring as balanced or unbalanced. This can be of help if you make your own cables.

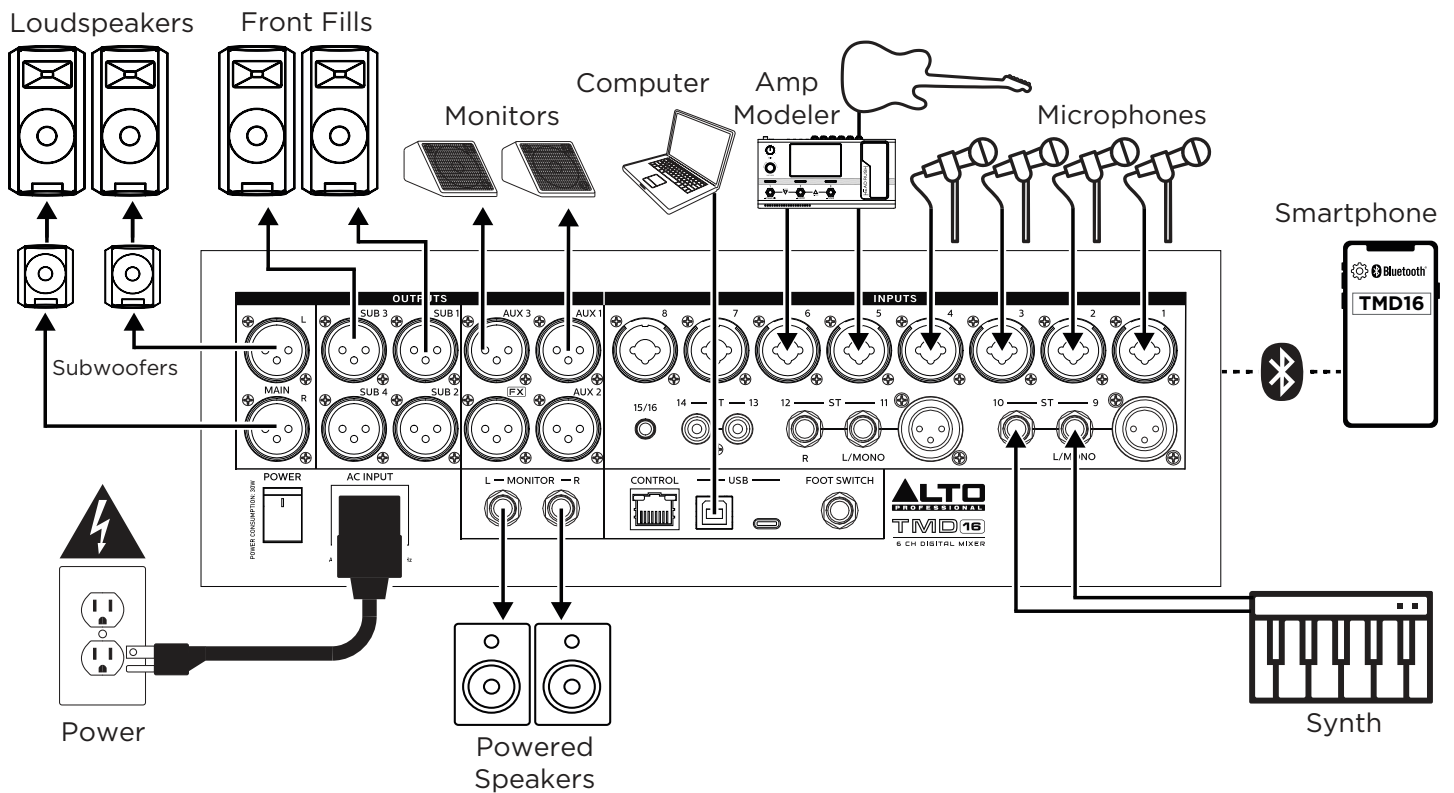
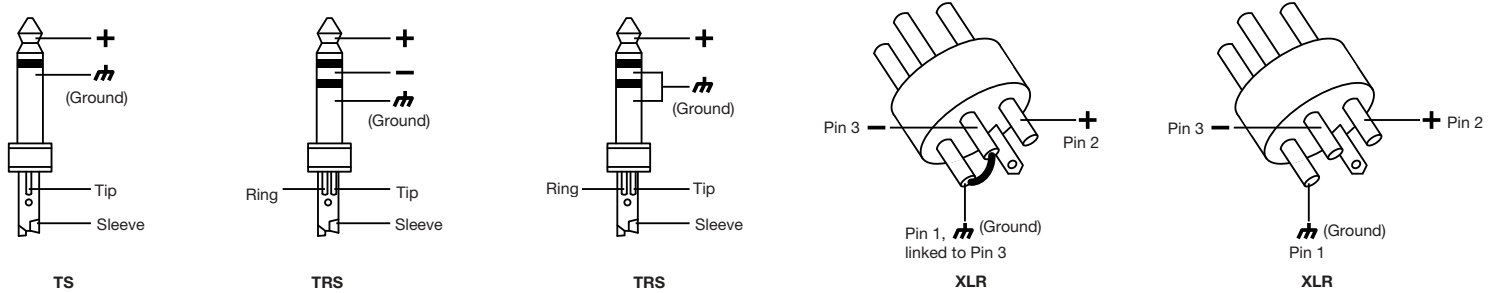

Common Setup Scenarios

Live Sound

1. Study the [Connection Diagram](#) section for ideas to plan your setup.
2. Choose a layout for your gear that compliments the venue's walkways, power locations, and acoustics (so you can properly hear your mix).
3. Make sure all devices are turned off.
4. Set all TMD16's **Channel Faders** to $-\infty$, **Hi Mid**, and **Low EQ** settings to 0 dB, and the **Monitor Level knob** to 0.
5. Connect all input sources, such as microphones, keyboard, electric guitar amp modeler, or a CD player to the appropriate XLR, 1/4" (6.35 mm), or RCA inputs.
6. If using TMD16's internal effects, see the section [Onboard Effects](#) for more details.
7. Connect all output sources.
8. Connect all devices to power outlets.
9. Switch everything on in the following order:
 - Audio input sources
 - TMD16
 - Last, any speakers or headphones
10. If using a Bluetooth® source, pair your Bluetooth device with TMD16. See the section [Connecting to a Bluetooth® Device](#) for more details.
11. Press the **SEL** button for the channel that has your first audio source. Have the performer test the mic at a level they will use when singing. Turn the top left encoder to adjust the channel's gain to a high level without clipping. Move your finger on the channel fader's touch strip, slowly moving it up until the output is at your desired level.

Repeat this process for the other channels that you're using.
12. If you are using stage monitors connected to the **Monitor Outputs**, turn up the **Monitor knob**.
13. Send TMD16's channels to the **Main Outputs** (for house loudspeakers) by adjusting the **Main Fader**.
14. When turning off equipment, follow this order:
 - Speakers or headphones
 - TMD16
 - Last, any audio input devices

Tips:

- If the sound is too boomy, decrease the low EQ frequencies.
- For more clarity, boost the high EQ frequencies.
- Use the internal effects subtly to add ambience. Remember a little goes a long way.
- Never point microphones and speakers at each other.
- Mute unused channels when they're not in use.
- Use board tape to label channels.
- Always have backup cables.

Recording

1. Study the [Connection Diagram](#) section for ideas to plan your setup.
2. Choose a layout for your gear that compliments your desk and power locations.
3. Make sure all devices are turned off.
4. Set all TMD16's **Channel Faders** to $-\infty$, **Hi Mid**, and **Low EQ** settings to 0 dB, and the **Monitor Level knob** to 0.
5. Connect all input sources, such as microphones, keyboard, or a sampler to the appropriate XLR or 1/4" (6.35 mm) inputs.
6. Connect a laptop for recording via a USB connection.
7. If using TMD16's internal effects, see the section [Onboard Effects](#) for more details.
8. Connect TMD16's **Monitor Outputs** to your speakers using 1/4" (6.35 mm) cables.
9. Connect all devices to power outlets.
10. Switch everything on in the following order:
 - Audio input sources
 - TMD16
 - Last, any speakers or headphones
11. Press the **SEL** button for the channel that has your first audio source. Have the performer test the mic at a level they will use when singing. Turn the top left encoder to adjust the channel's gain to a high level without clipping. Move your finger on the channel fader's touch strip, slowly moving it up until the output is at your desired level.

Repeat this process for the other channel's that you're using.
12. Send TMD16's channels to the **Main Outputs** (for house loudspeakers) by adjusting the **Main Fader**.
13. Turn up the **Monitor knob** until a desired volume is reached.
14. When turning off equipment, follow this order:
 - Speakers or headphones
 - TMD16
 - Last, any audio input devices

USB Setup

macOS users: No driver installation is needed for class-compliant operation with TMD16.

Windows users: Before connecting TMD16 to your computer, make sure to first install the Windows drivers as detailed below.

Downloading Drivers:

1. Go to altoprofessional.com/products/tmd16 and download the latest TMD16 driver for your operating system.
2. Open the file you downloaded and double-click the driver installer file.
3. Follow the on-screen instructions to install the drivers.

Driver Setup:

To set TMD16 as your default playback device, follow the directions below based on your computer's operating system.

Windows 11:

1. Use the included USB cable to connect the TMD16 to your computer.
2. In the Taskbar, locate the **Volume Control** "speaker" icon. Right-click the speaker and open **Sound Settings > Sounds**, then select **More sound settings**.
Alternatively, go to **Start Menu > Settings (System) > Sound** and then select **More sound settings**.
3. In the **Windows Sound** control panel select the **Playback** tab and select **USB Audio Codec** as the default device.
4. Click the **Recording** tab and select **USB Audio Codec** as the default device.
5. Click **Properties** in the lower right-hand corner.
6. In the new window, click the **Advanced** tab and select **2-channel, 16-bit, 48000 Hz (Studio Quality)** as the default format.
7. Uncheck both boxes under **Exclusive Mode**.
8. Click **OK** to close the Properties window.
9. Click **OK** to close the Sound control panel.

macOS:

1. Use the included USB cable to connect the TMD16 to your computer.
2. Go to **Applications > Utilities > Audio MIDI Setup**.
3. In the **Audio Devices** window, select **USB Audio Codec** in the left column.
4. Right-click **USB Audio Codec**, and select **Use this device for sound input**.
5. Right-click **USB Audio Codec**, and select **Use this device for sound output**.
6. Quit Audio MIDI Setup.

Top Panel

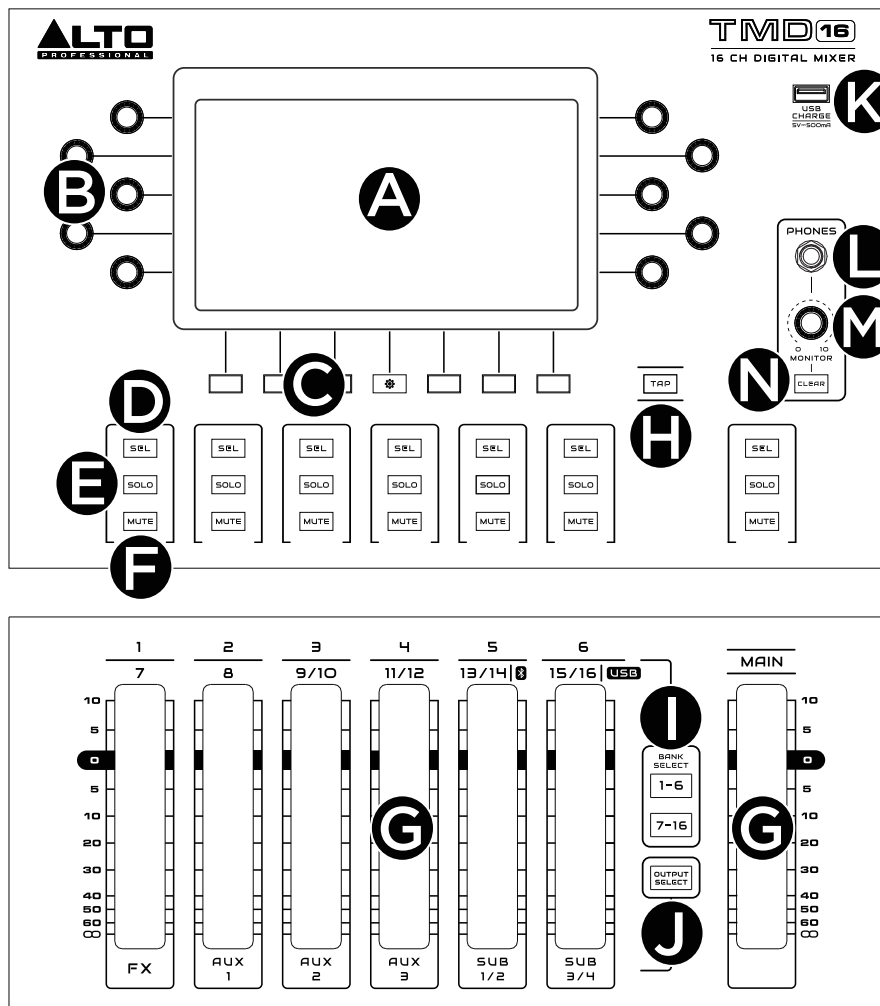

A. DISPLAY

This 7.0" (17 cm) display serves as the primary interface for viewing the digital mixer functions.

B. KNOBS

Turn these ten endless rotary knobs to control the digital mixer functions on the display. The encoders are split five-left and five-right and have functions aligned with them per input or output channel selected as well as the FX engine. Push a knob to cycle through multiple settings (when available).

C. FUNCTION BUTTONS

These seven backlit buttons control digital mixer functions on the display. Press the center button to exit the current menu and return to the main meters Overview screen. While viewing the Overview screen, press the center button to open the Presets screen.

D. CHANNEL SELECT

Press these white backlit buttons to select an individual channel for editing EQ, adding compression, and assigning outputs. Only one channel can be selected at a time. See the section [Channels](#) for more details.

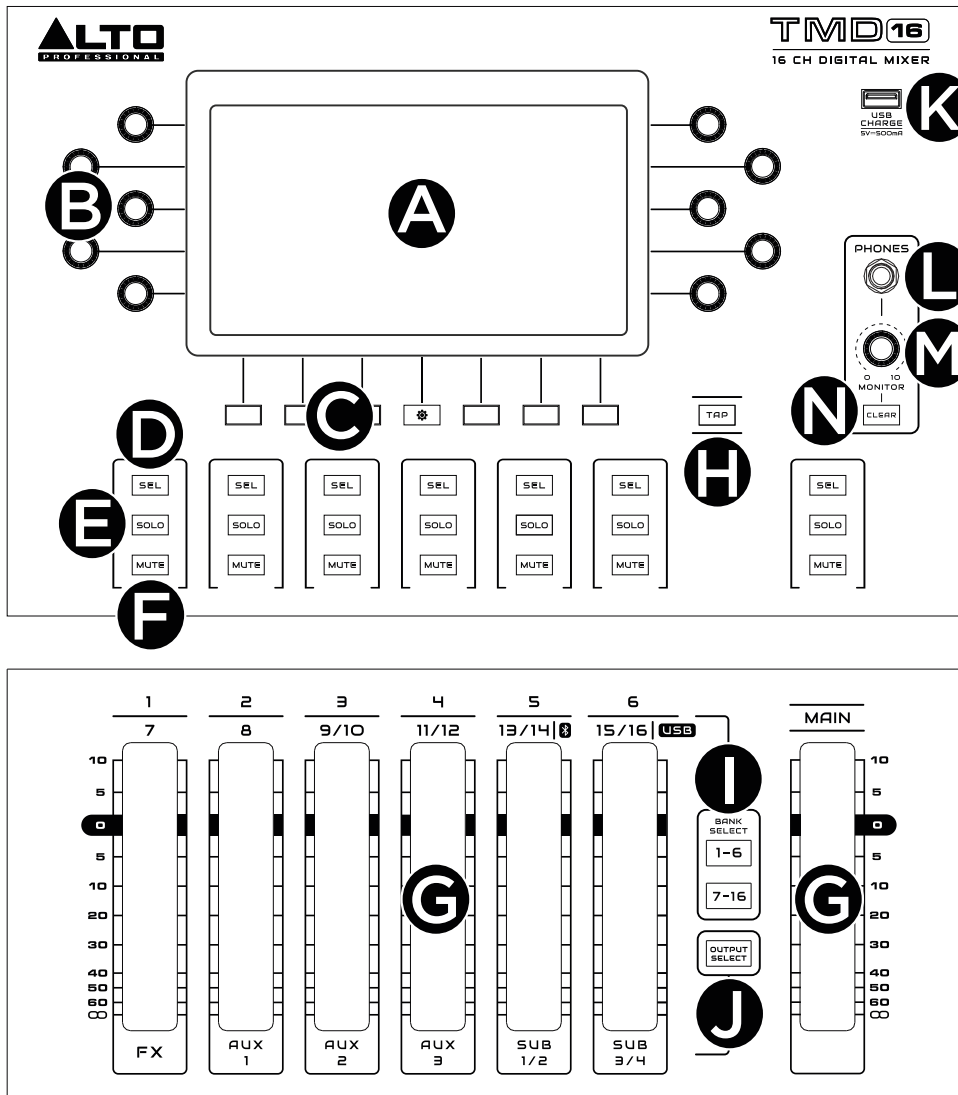

E. CHANNEL SOLO

Press these yellow backlit buttons to select the respective input or output channel to be solo'd. When a channel is solo'd, it will mute all other channels in the Headphone and Monitor Outputs, with the exception of the solo'd channel. The solo'd channel can be cleared by pressing the **Clear** button. See the section [Soloing a Channel](#) for more details.

F. CHANNEL MUTE

Press these red backlit buttons to mute any of the input and output channels. See the section [Muting a Channel](#) for more details.

G. FADERS

These 100 mm capacitive touch faders with LEDs provide control of the selected input. The **Main Fader** controls the level sent to the Main Output. Tap and drag your finger from the current LED location to adjust the level.

Note: The fader level and associated LED will not snap to a touch point.

H. TAP

Press this button at a rhythmic interval to set a delay time value for the onboard FX.

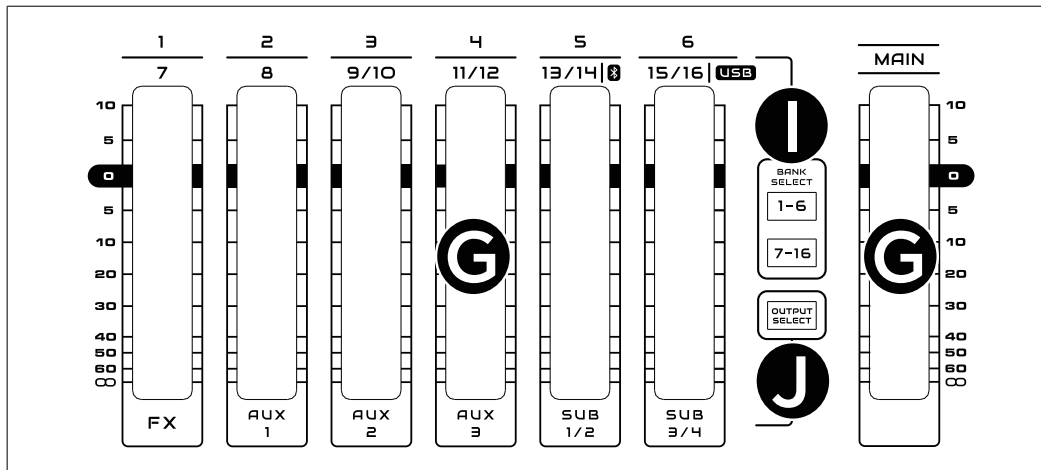
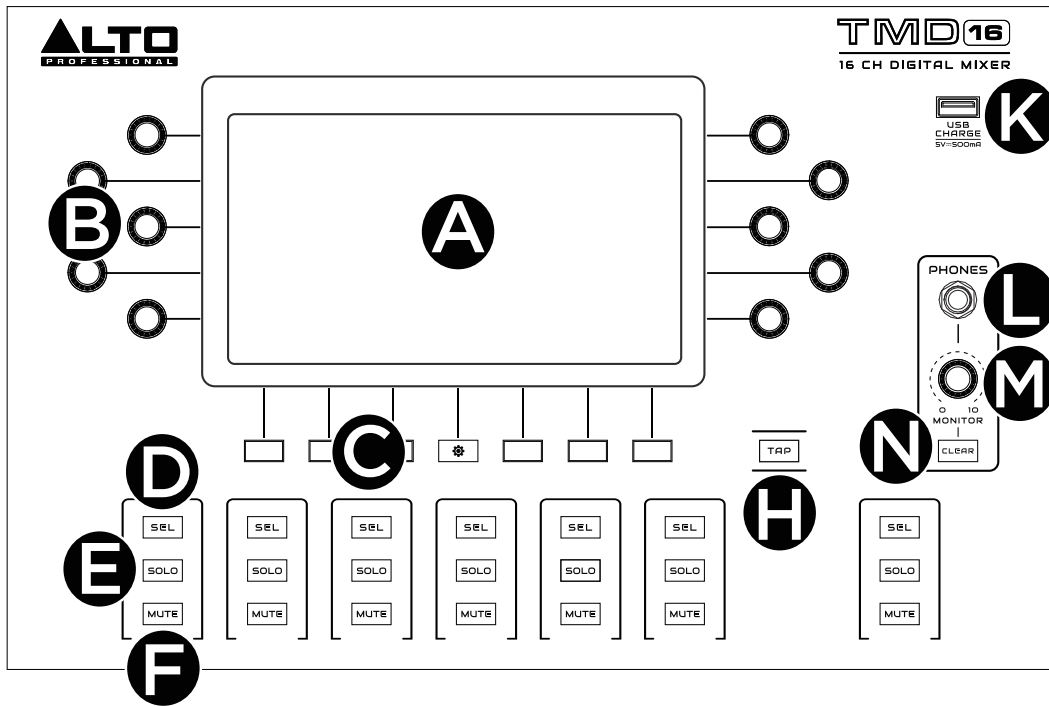

I. BANK SELECT

Press these buttons to set the **Channel Faders** to control Inputs 1-6 or 7-16.

J. OUTPUT SELECT

Press this button to set the **Channel Faders** to control the output channels, as displayed at the bottom of each fader. The **Main Fader** always controls the L/R **Main Output**.

K. USB

Use this port for charging or providing power to USB devices.

L. PHONES

Connect headphones to this 1/4" (6.35 mm) TRS output for monitoring.

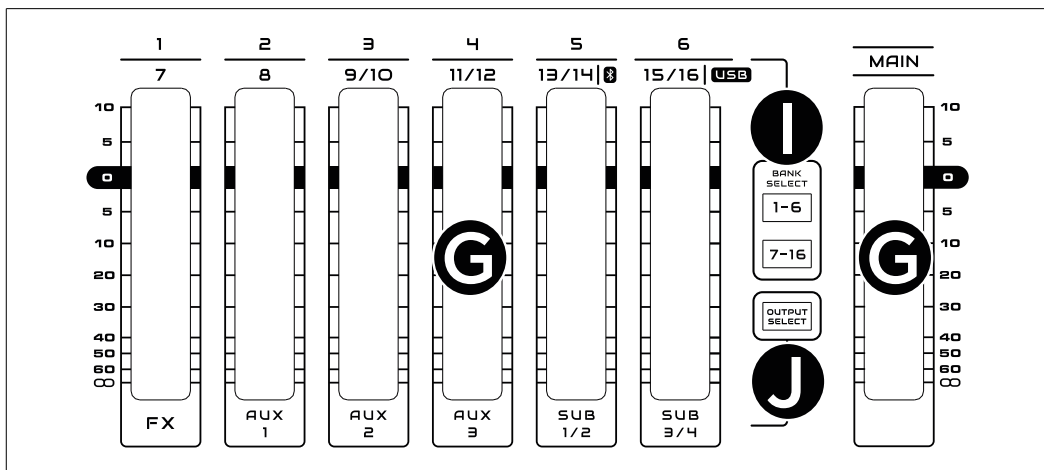
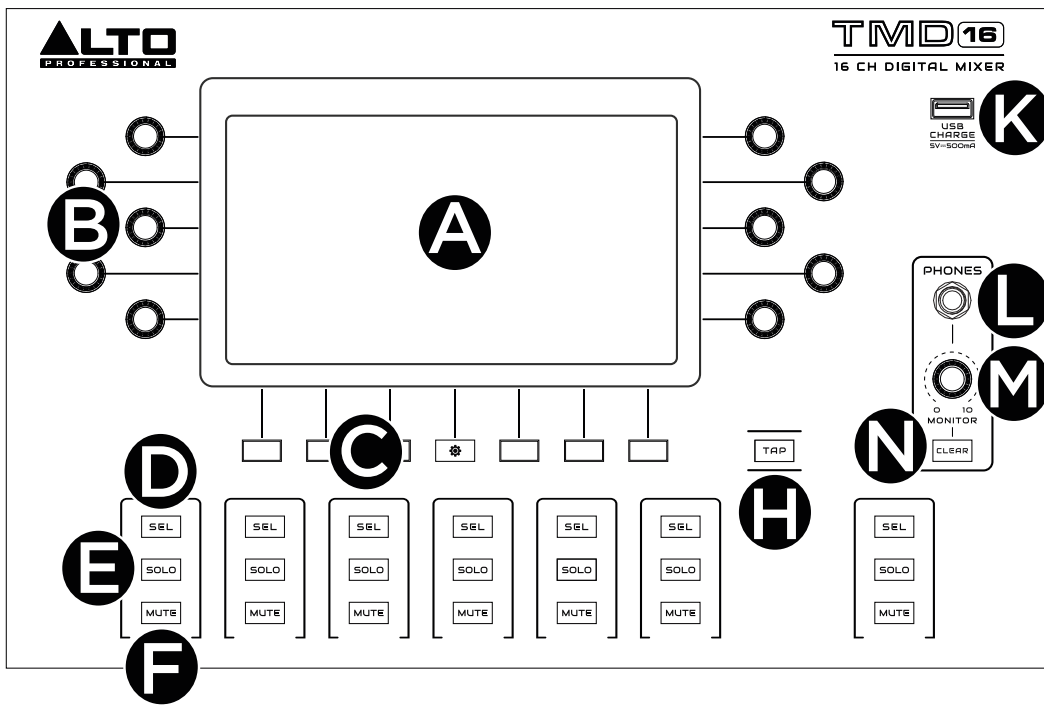

M. MONITOR

Turn this knob to adjust the output monitoring level for the **Phones** and **Monitor Outputs**.

N. CLEAR

Press this button to clear any solo channels.

Rear Panel

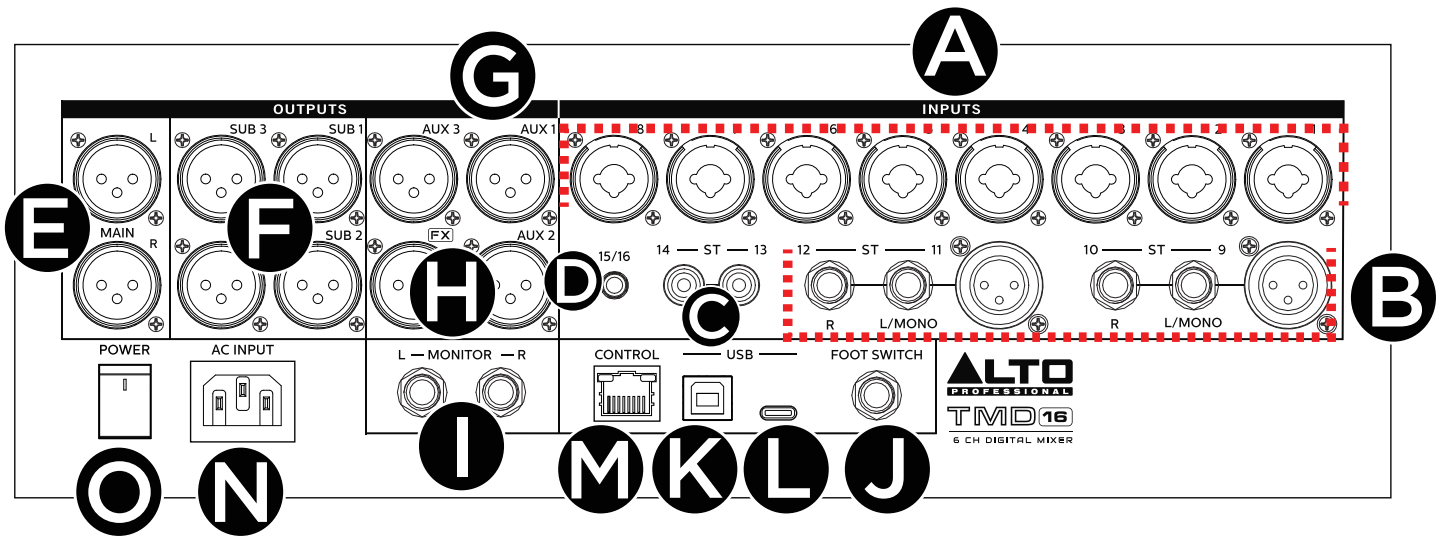

A. INPUT CHANNELS 1-8 (XLR / 1/4" [6.35 mm] TRS)

Connect audio devices to these mono mic/line inputs. The inputs are controlled via Fader Channels 1-8.

B. INPUT CHANNELS 9-12 (XLR or Dual 1/4" [6.35 mm] TRS)

Connect audio devices to these stereo pair mic/line inputs. These are seen as two-channels in the UI but offer both a mic-level XLR input as well as a stereo pair of TRS line-level inputs. The inputs are controlled via Fader Channels 9-12.

C. INPUT CHANNELS 13-14 (Dual Stereo RCA/Bluetooth)

These stereo channels provide two RCA line-level inputs. The inputs are controlled via Fader Channels 13-14.

D. INPUT CHANNELS 15-16 (Stereo 1/8" [3.5 mm] / USB)

This stereo channel provides a 1/8" (3.5 mm) TRS line-level input signal and the signal from a paired Bluetooth device. The input is controlled via Fader Channels 15-16.

E. MAIN OUTPUT (XLR)

Connect loudspeakers, subs, monitors, recorders, or other devices to these stereo outputs. These outputs are controlled via the **Main Fader**.

Note: Each output can be controlled by pressing the **Output Select** button on the top panel and using the associated fader.

F. SUB 1-4 OUTPUTS (XLR)

These dual stereo subgroup line-level outputs feature four XLR connectors. The outputs are controlled by the Output Fader Bank via the Sub 1/2 and Sub 3/4 faders.

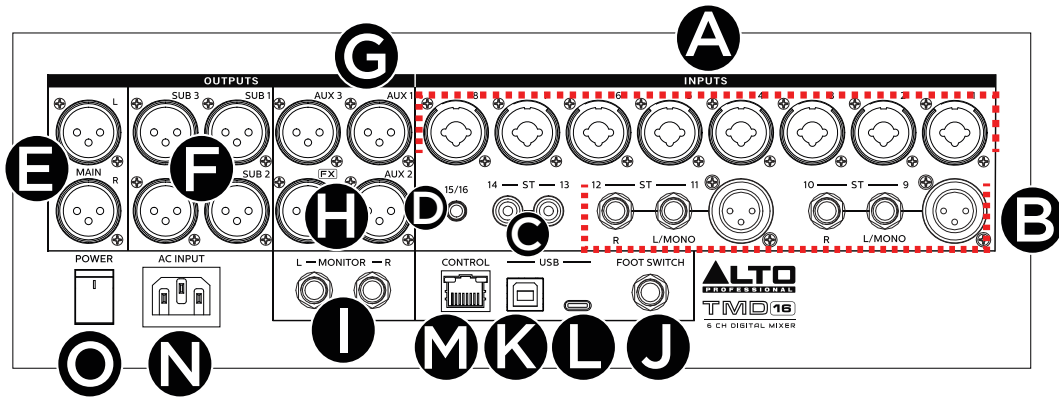

G. AUX 1-3 OUTPUTS (XLR)

These three mono auxiliary line-level outputs feature three XLR connectors. The outputs are controlled from the Output Fader Bank via the AUX 1-AUX 3 faders.

H. FX OUTPUT (XLR)

This mono line-level output features an XLR connector and sends a mix with the effects applied. The outputs from the Output Fader Bank via the FX fader. See the [Onboard Effects](#) section for more details.

I. STEREO MONITOR OUTPUT (1/4" [6.35 mm] TRS)

This stereo left/right line-level output features two TRS connectors. The output is in parallel to the **Headphone Output** and is controlled via the **Monitor** knob.

J. FOOTSWITCH (1/4" TS)

Connect an optional footswitch to this input to mute and unmute the FX channel.

K. USB-B

Connect a computer to this port for stereo audio input and output.

L. USB-C®

Connect a computer to this port for stereo audio input and output.

M. CONTROL

Use this Ethernet port to access the control protocol system for the mixer.

N. POWER INPUT

Use the included power cable to connect to a power outlet.

O. POWER SWITCH

Use this switch to turn TMD16 on and off. When powering on, turn on all input devices first, then TMD16, then output devices. When powering off, turn off output devices first, then TMD16, then input devices.

Main Meters

The Main meters screen is the default screen for the TMD16. Press the **System** (cogwheel icon button) on any screen to return to the Main Meters screen.

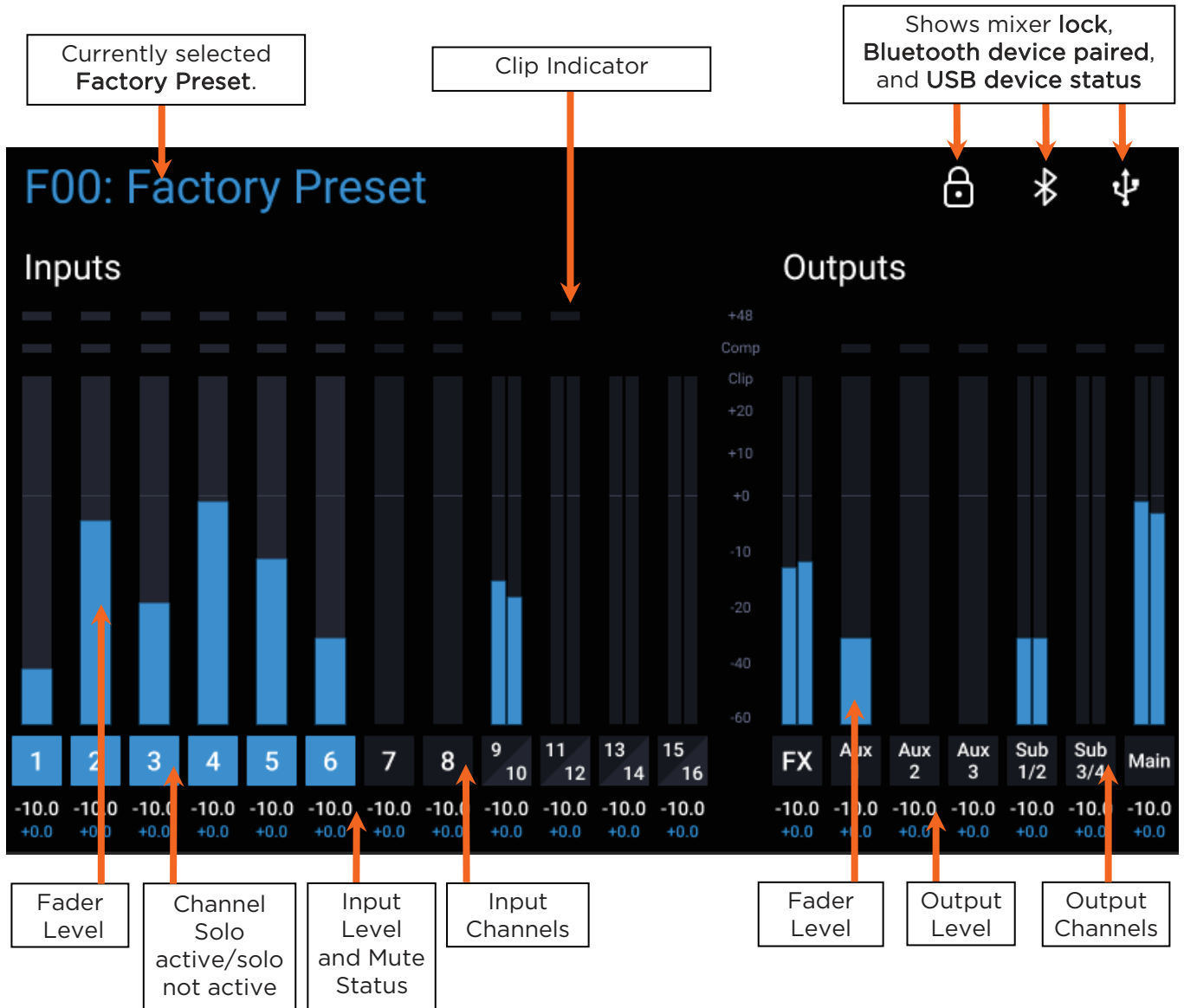

Encoder Knobs and Function Buttons

The Channel page of the mixer shows the currently selected channel's settings.

The diagram illustrates the Channel page interface of a mixer. The central screen displays various settings for a selected channel (Channel 1). On the left side of the screen, there are four encoder knobs for Gain (0 dB), Comp Threshold (+20.0 dB), High Gain (0.0 dB), and Mid Gain (0.0 dB). On the right side, there are four encoder knobs for Pan (C), PFL Aux1 (-80.0 dB), PFL Aux2 (-80.0 dB), and PFL Aux3 (-80.0 dB). The bottom of the screen features a row of function buttons: +48, HPF, FBX, Exit (with a cogwheel icon), L/R, 1/2, and 3/4. The Equalizer section shows a graph with L, M, and H frequency sliders. The Compressor section shows a graph with a threshold line. The diagram includes callouts: an orange box on the left highlights four encoder knobs with an arrow pointing to a text box; an orange box on the right highlights four encoder knobs with an arrow pointing to a text box; and an orange box at the bottom highlights seven function buttons with arrows pointing to a text box.

Turn these left-side **encoder knobs** to adjust on-screen parameters. Push a knob to cycle through multiple options (when available).

Turn the right-side **encoder knobs** to adjust on-screen parameters. Push a knob to cycle through multiple options (when available).

Press the **function buttons** to control the associated on-screen functions. Press the center **System** (cogwheel icon) button to exit the menu and return to the Main Meters Overview screen.

Selecting a Channel and Adjusting Settings

1. Press **Bank Select 1-6, 7-16, or OUTPUT SELECT** to set the channel faders to control Channels 1-6, 7-16, or the Output Channels.
2. Press the **Sel** button above the channel you would like to edit.
3. Turn one of the 10 rotary **Knobs** to adjust the corresponding control shown on the display. If a control has multiple parameters, you will see a circle next to the control on the display. Push the corresponding knob to cycle through the available settings.



Channels

Turn the top left encoder knob to adjust the **Gain** or **Fader** level for the currently selected channel. Push the encoder to select controlling the **Gain** or **Fader** level. The gain range is 0 to 50 dB in increments of 1 dB (default is 0 dB). The **Gain** range is 0 to 50 dB in increments of 1 dB (default is 0 dB). The channel's **Fader** level range is $-\infty$ dB to 10.0 dB.

The **channel meter** provides both the pre-fader and post fader metering to allow you to set gain staging. The light blue level is the pre-fader level and the dark blue is the post fader level.

Push the associated bottom function button to turn on **+48V** for microphones per channel that require phantom power.

Press these buttons to set the **channel faders** to control Inputs 1-6 or 7-16.

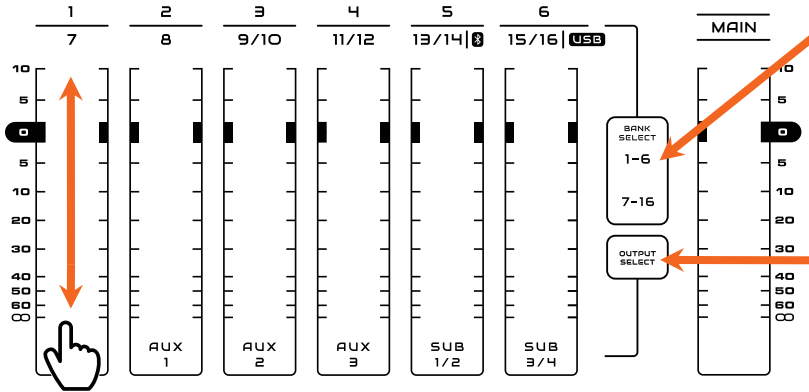

Press the **output select** button to set the channel faders to control the output channels displayed at the bottom of each fader.

Tap and drag your finger from the current LED location to adjust the fader level. The channel's fader level range is $-\infty$ dB to 10.0 dB (default is $-\infty$ dB). You can also dial in the exact level of the fader by selecting the channel you would like to edit, and pressing the top left encoder to select Fader. Once Fader is shown next to the top left encoder, use the encoder to dial in the exact level.

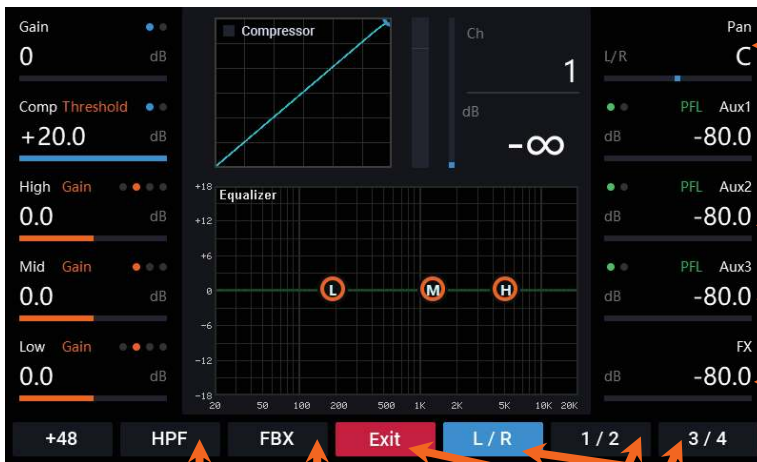

Sets the channel's pan range from L100 to Center to R100 (default is center).

Sets the Aux Sends level. Push the encoder to toggle between PFL (Pre-Fader Level) and AFL (After-Fader Level). Default is PFL. The send control range is -80 dB to +10 dB in increments of 0.5 dB (default is -80 dB).

Sets the level sent to the FX engine. The send control range is -80 dB to +10 dB in increments of 1 dB (default is -80 dB).

Toggles through the high pass filter settings: OFF, 80 Hz, and 100 Hz (default is OFF).

Turns the input channel automatic feedback eliminator on and off (default is OFF).

Exits the channel settings screen, turns off the selected channel backlit button, and returns to the main

Selects or deselects the output **channel routing** from L-R (default is on), sub 1-2, and 3-4 (default is off).

Soloing a Channel

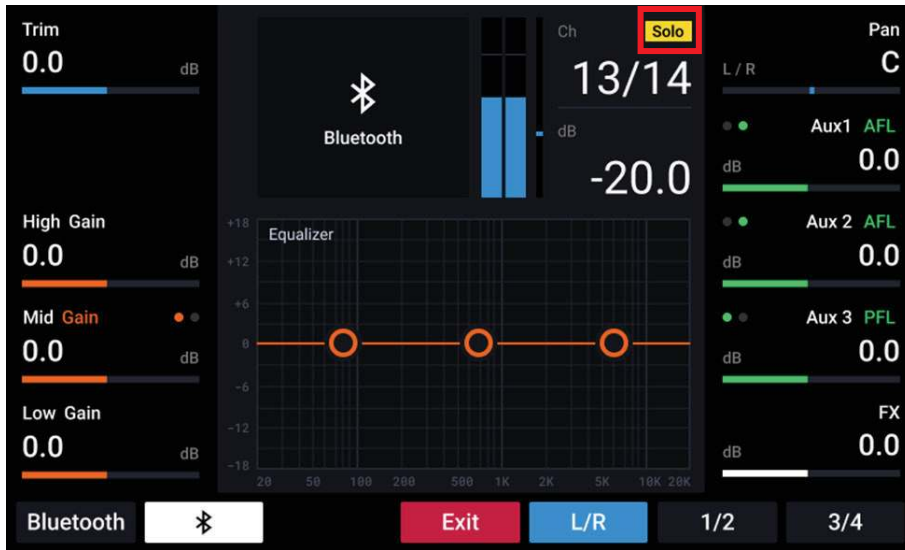

The area to the right of the channel level, the **Channel View**, displays the Solo icon when the channel is solo'd.

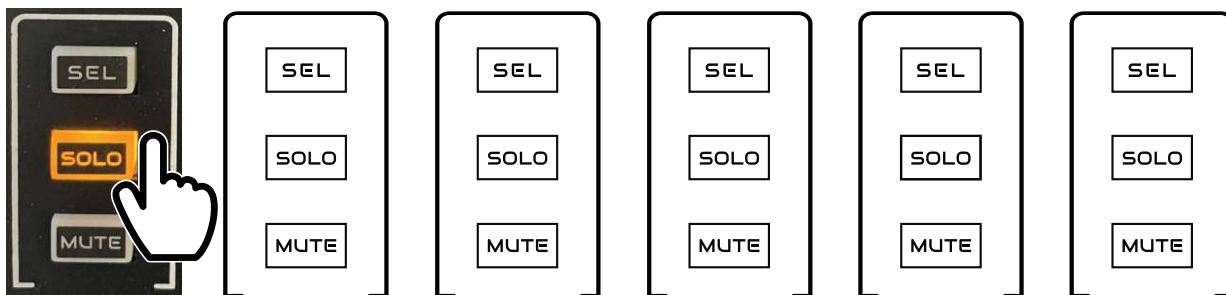

Press a **Solo** button to solo a mixer channel. The button will illuminate yellow when solo'd.

Muting a Channel

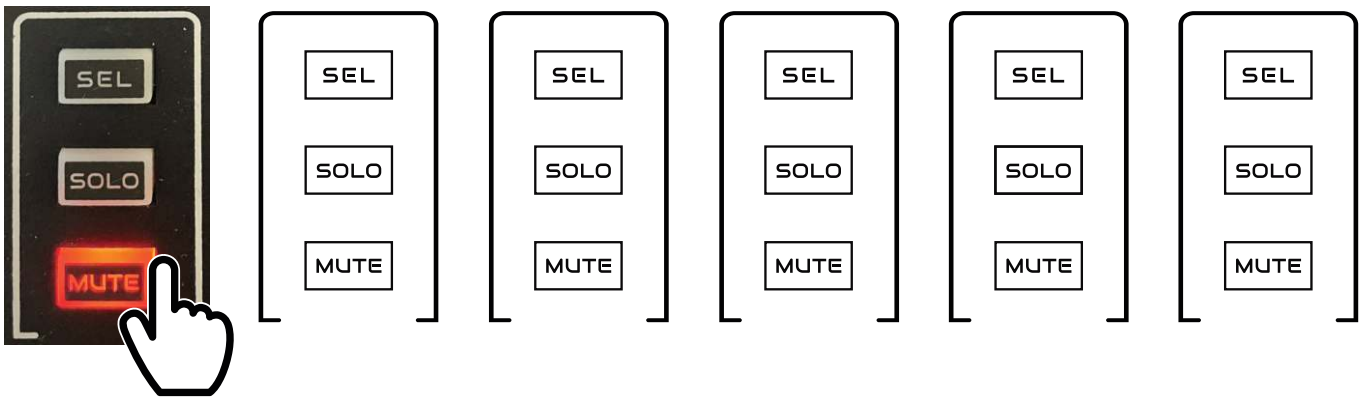
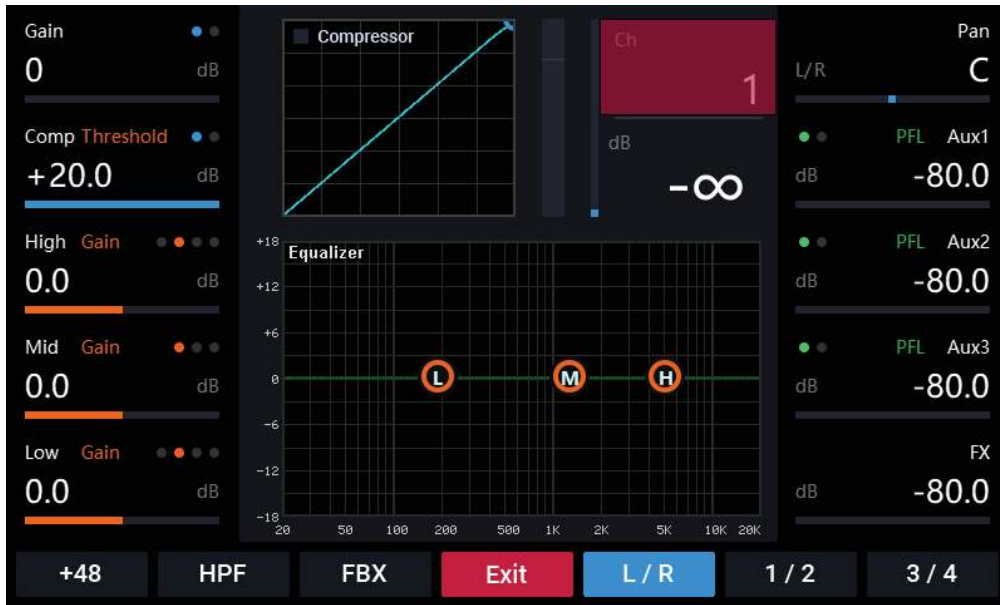

Press a **Mute** button mute a mixer channel. The mute button and channel number on the display will illuminate red when muted.

Output Select

Press the **Output Select** button to set the channel faders to control the FX, Aux 1-3, or Sub 1/2-3/4 Output Channels.

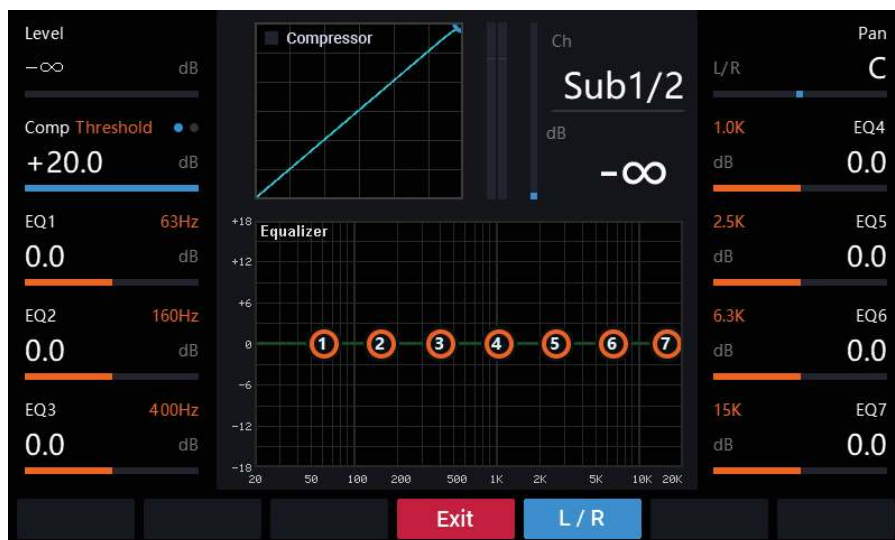
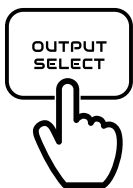

EQ

INPUT CHANNELS

Turn the 3rd-5th encoders to adjust the **3-band EQ** settings.

Push the encoder to select the **Parametric** or **Shelf** filter (for the high and low bands), **Gain** (+/- 12 dB of control, default is 0 dB), **Frequency** (20 Hz to 20 kHz with logarithmic steps). **Q** parameter adjusts the width or narrowness of the filter (range of 0.4 wide to 15 narrow, default is 0.5 for Shelf, 1.0 for Parametric).

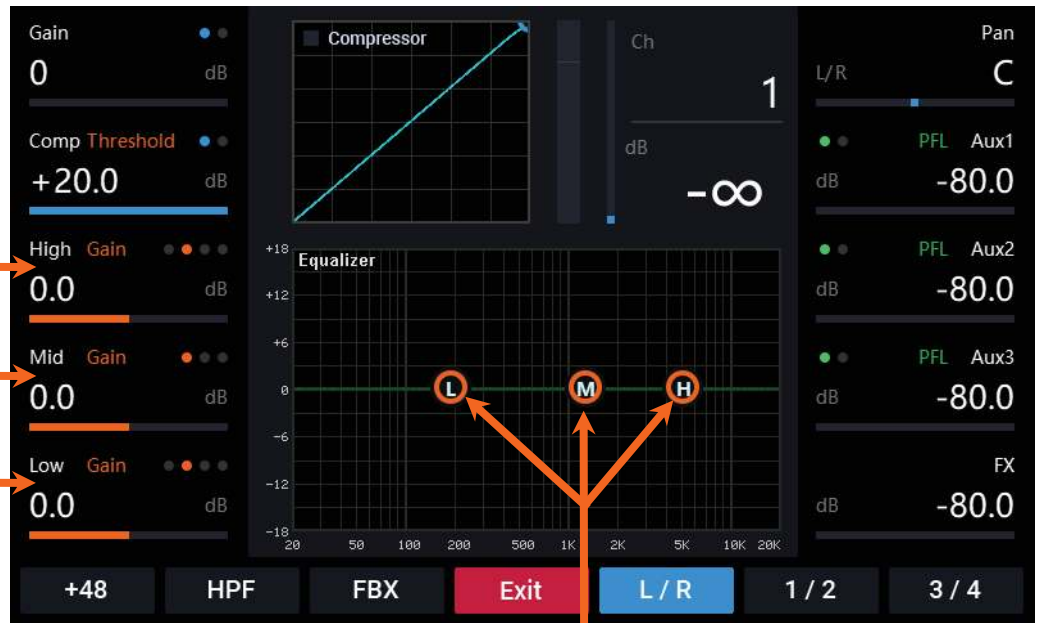

The EQ Display X/Y graph shows each of the the 3-band EQ parameters (Low, Mid, and High).

OUTPUT CHANNELS

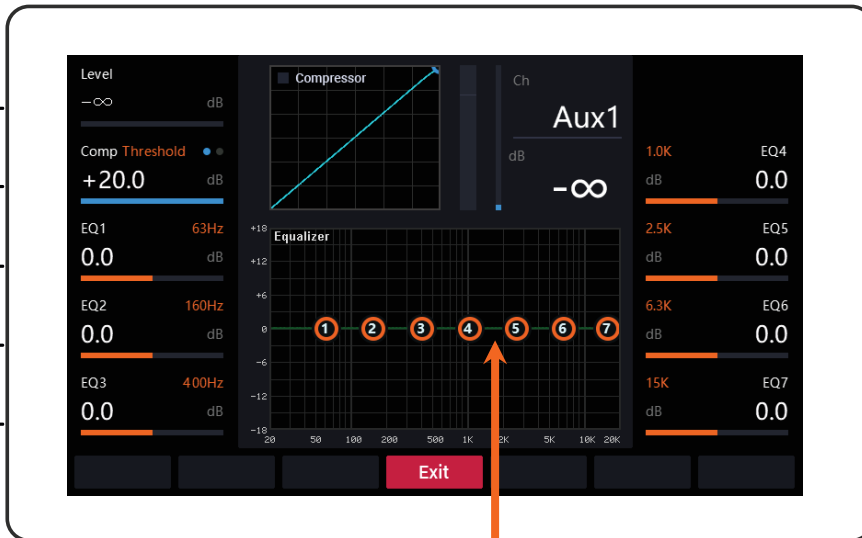

Encoders 3-5 control the gain for the fixed 7-band EQ (+/-12 dB of gain, default is 0).

Encoders 2-5 control the gain for the fixed 7-band EQ (+/-12 dB of gain, default is 0).

Frequency Bands:
 EQ band 1: 63 Hz
 EQ band 2: 160 Hz
 EQ band 3: 400 Hz
 EQ band 4: 1 kHz
 EQ band 5: 2.5 kHz
 EQ band 6: 6.3 kHz
 EQ band 7: 15 kHz

Compressor

Use the built-in compressor to better control levels. It makes the softer signals louder and the louder signals softer, managing the signal for you. Use it to tame muddy bass guitars, on a kick drum to manage low-end frequencies, or to smooth out vocals.

Turn the second encoder on the left to adjust the compressor settings. Push the encoder to toggle between **Compressor Threshold** and **Ratio** (default is Comp Threshold). The threshold control range is -90 dB to +20 dB in increments of .5 dB (default is +20dB). The ratio options are 1:1, 1:1.1, 1:1.3, 1:1.5, 1:1.7, 1:2, 1:2.5, 1:3, 1:3.5, 1:4, 1:5, 1:6, 1:8, 1:10, 1:20, LIMIT (default is 1:10).

The **Compressor Display X/Y** graph shows the adjusted threshold and ratio control settings.

Threshold: The threshold sets the level where the compressor will start “listening” to the audio signal. If the audio signal is low and the threshold is set too high, it won’t reach the required level to apply any compression. The audio will need to reach the threshold before the compressor starts to affect the signal.

Ratio: This sets the amount of compression. For example, if the audio signal goes over the threshold and the ratio is set at 1:2 then it will divide the amount that goes over the threshold in half and compress the signal down by two.

Compressor Tips:

- Try a ratio between 1:4 and 1:8 for a medium compression level to the signal.
- Start with a lower threshold (-3 dB) and ratio (1:5) to gently reduce the signal’s dynamic range without getting an audible pumping or breathing effect.
- Experiment with compression settings to tighten drums, level vocals, or make an instrument stand out in the mix.
- Be cautious not to squash the dynamic range of the audio signal. Over-compression can distort the natural tone of instruments and vocals.

Onboard Effects

Turn the left top encoder to select the FX **Type**. Push the encoder to activate the selected effect.

Turn Encoders 2-5 on the left to adjust the various FX **Parameters**.



Turn the right top encoder to adjust the FX channel's fader **Level** from $-\infty$ dB to 10.0 dB (default is $-\infty$ dB).

Set the Aux Sends to be **PFL** (Pre-Fade Listen) or **AFL** (After-Fade Listen)

To add effects to a channel:

1. Press the **Sel** button for the channel where you would like to add FX.
2. In the channel's settings window, use the **Knob** that corresponds to "FX" and turn it until the level is set to 0.0 dB.

Note: The FX level can be set for any available value and changed later.

3. Press the **Output Select** button.
4. On the FX output channel, press the **Sel** button to open the FX channel's settings window.
5. Use the top left **Knob** to browse effects, and then press it to select one.
6. Use **Knobs 2-5** to control the various FX parameters, such as Tone, Decay, and Rate. Use **Knobs 6-10** to adjust the overall effect level, and how much of the effect is going to Aux 1-3.
7. In the FX channel's setting window, press the **Function Button** associated with the output where you would like to send the FX (L/R, 1/2, 3/4).

Note: The FX channel will send audio out to the FX output.

8. Move the **FX Channel Fader** up to hear the effect.

Note: Use an optional footswitch (sold separately) connected to the **Footswitch** input to toggle the effect on/off.

Effects List

Effect Name	Effect Type	Parameter 1	Parameter 2	Parameter 3	Parameter 4
Short Room	Reverb	Decay - default 372ms	Tone - default 60%		
Room A	Reverb	Decay - default 656ms	Tone - default 40%		
Room B	Reverb	Decay - default 656ms	Tone - default 60%		
Plate	Reverb	Decay - default 1.46s	Tone - default 25%		
Hall A	Reverb	Decay - default 1.02s	Tone - default 30%		
Hall B	Reverb	Decay - default 1.02ms	Tone - default 45%		
Church	Reverb	Decay - default 1.46s	Tone - default 20%		
Cathedral	Reverb	Decay - default 1.99s	Tone - default 0%		
Spring	Reverb	Decay - default 592ms	Tone - default 70%		
Short Delay	Delay	Time - 387 BPM / 155ms	Repeat - 60%		
Long Delay	Delay	Time - 307 BPM / 195 ms	Repeat - 60%		
Chorus A	Chorus	Rate - 2.13Hz	Depth - 58%		
Chorus B	Chorus	Rate - 0.55Hz	Depth - 100%		
Chorus C	Chorus	Rate - 2.76Hz	Depth - 100%		
Rev + Dly 1	Reverb/Delay	Reverb time - 1.46s	Delay Time - 307 BPM / 195ms	Delay Repeat - 60%	Mix: R50: D50
Rev + Dly 2	Reverb/Delay	Reverb time - 656ms	Delay Time - 307 BPM / 195ms	Delay Repeat - 60%	Mix: R50: D50

Connecting to a Bluetooth® Device

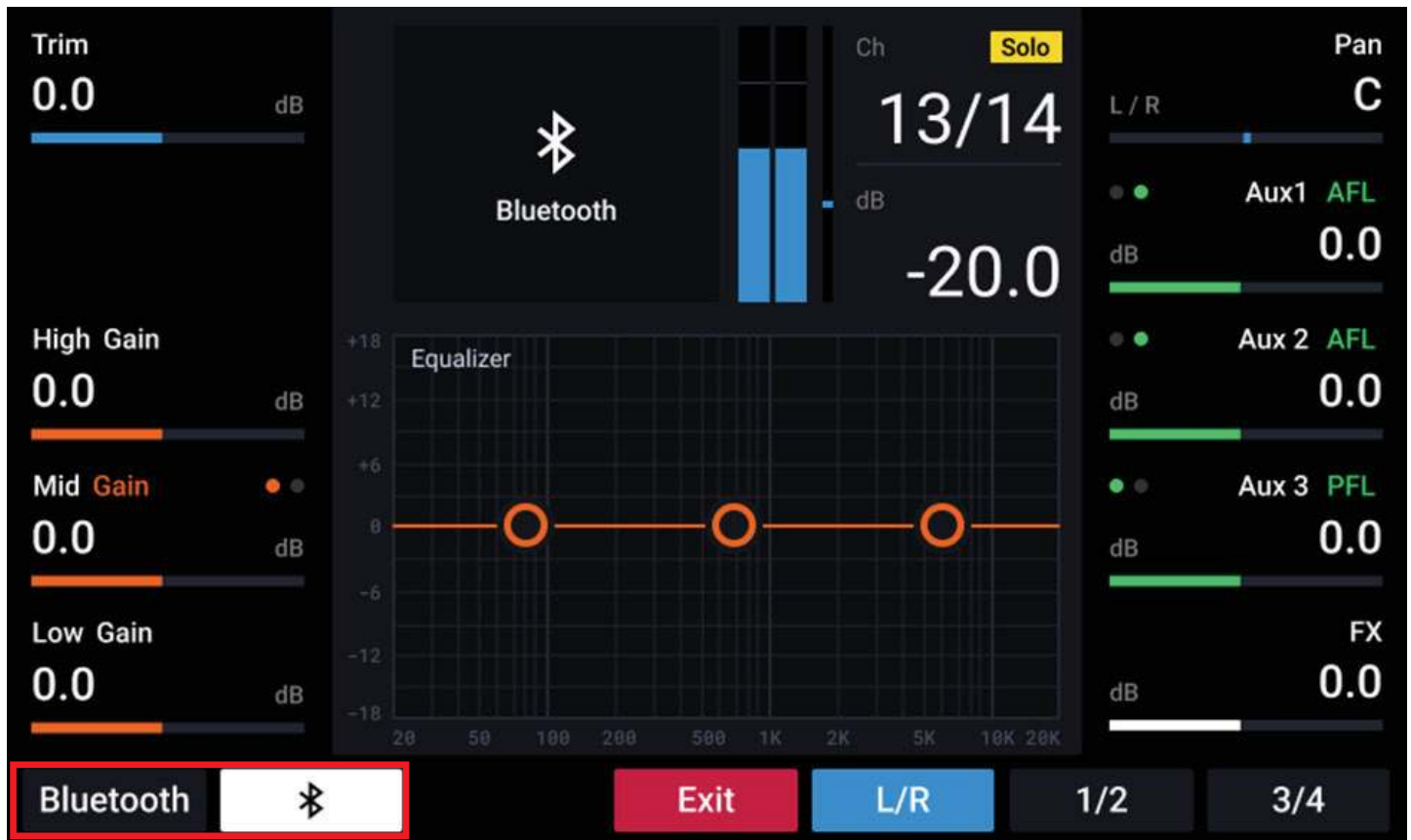

1. Press the **Bank Select 7-16** button.
2. On Channel 13/14 | BT, press the **Sel** button.
3. The mixer will be in pairing mode when the Bluetooth icon is blinking. If it is not, press the **Function** button under Bluetooth icon on the screen.
4. On your Bluetooth audio source, go into your Bluetooth settings and pair a new device.
5. Select "TMD16 BT" from the list of available devices. Once paired, the Bluetooth icon will be lit solid.
6. Make sure your Bluetooth device volume is turned up, then begin playing audio. Adjust the Channel 13/14 | BT volume as needed.

System Screen

To access the **System menu**, first go to the Main Meters overview screen, then press the center **System** (cogwheel icon) button below the display.

The System screen houses multiple functions for the mixer including:

- Mixer password protection
- Wired network connectivity settings
- Full factory reset
- Firmware version and upgrade functions
- Save and load mixer presets
- Channel copy and restore to factory default

Use the corresponding encoder push button to access parameter controls for each of the functions.

Preset Menu

Presets are a snapshot of all parameters of the mixer which are saved and can be recalled. There is one factory preset to return the mixer to factory default settings and nine user presets that can be saved, copied, and reloaded.

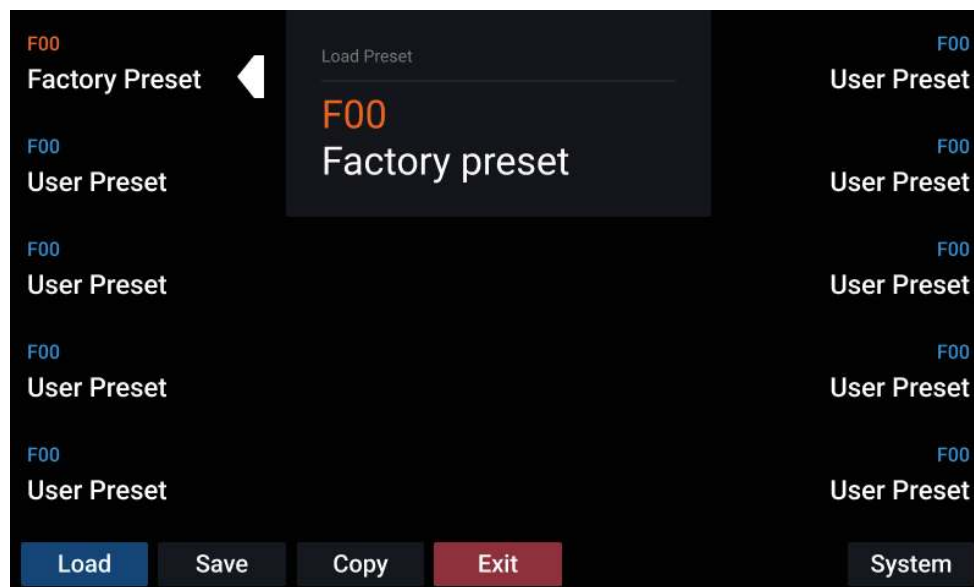

Loading a Preset

1. Press any of the 10 encoder buttons to select a preset, indicated by the arrow icon.
2. To Load Preset, select **Load**.
3. Press **OK** to load or **Cancel** to exit the preset loading screen.

Saving a Preset

1. Adjust all of your channel controls (panning, EQ, compression, etc.) to the desired settings.
2. Press the middle **System** (cogwheel icon) button to enter into the Presets screen, and then press the **Function** button under "SAVE" on the screen.
3. Press the **Encoder** knob matching the location of where you would like the preset stored. For example, U01 (User 01).
4. Use the top left **Encoder** knob to enter the name of your preset. Turn it to scroll through letters and numbers, and then press it to select each character.
5. Once you've completed entering the name of your preset, press the **Function** button under "OK" on the screen.
6. Use the Load button on the preset screen to load this preset.

Copying Channel Settings

All of the settings for any individual channel can be copied to another channel using the **Copy** button at the bottom of the preset screen.

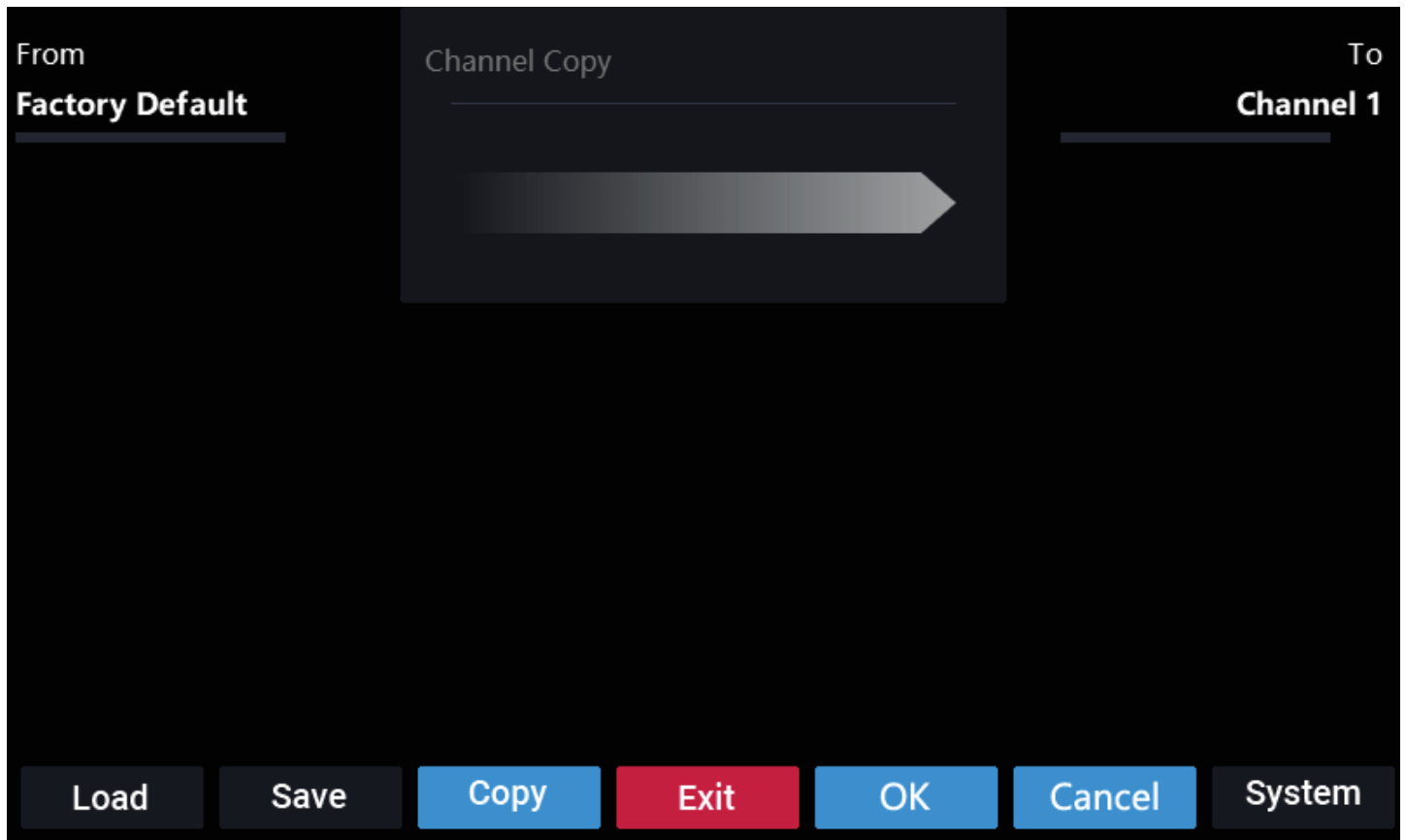

1. Select **Copy** at the bottom of the preset screen.
2. Use the left top encoder and the right top **Encoder** to select the channel to be copied and the channel where the setting will be copied to.
3. Use the **OK** or **Cancel** buttons to complete the process.

Note: Turning the top left Encoder counterclockwise from Channel 1, you will see “Factory Default”. Selecting Factory Default will reset the channel’s parameters to its factory default settings.

Password Protection

Select **Password** using the corresponding encoder push button to access the mixer's password protection screen. From there you can enter the numerical password.

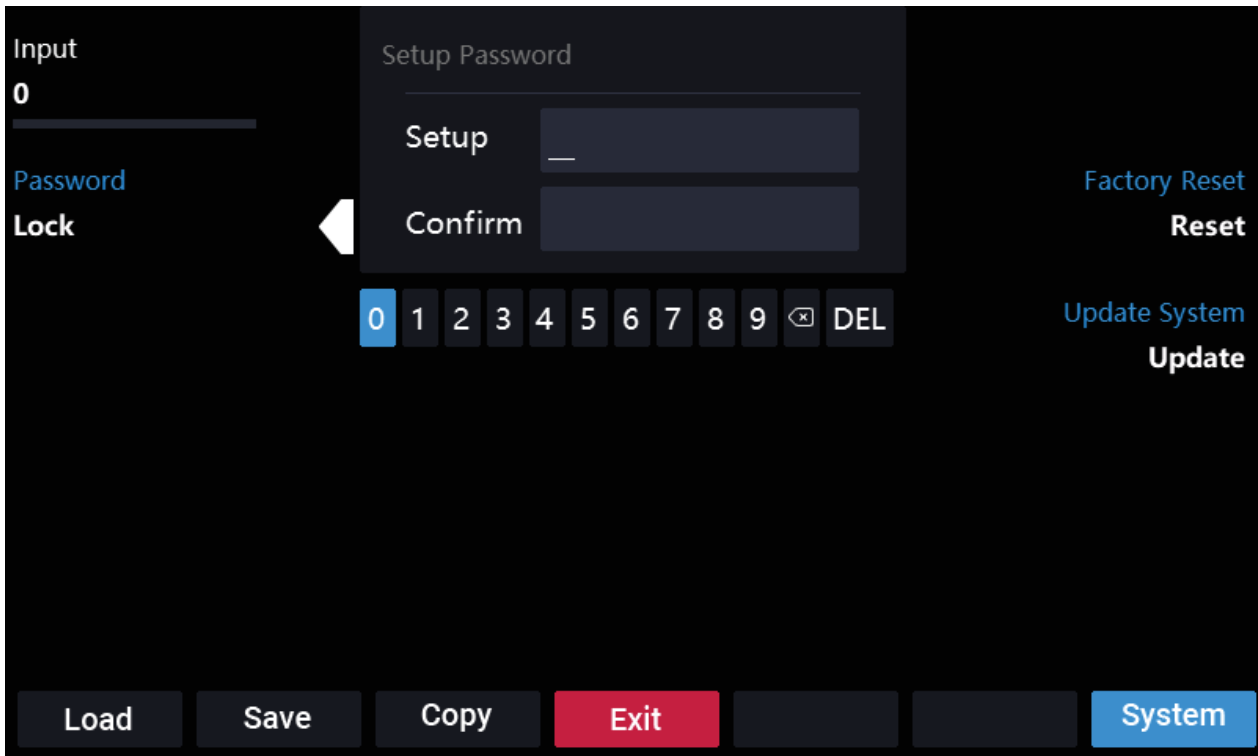

Firmware

Select **System** using the corresponding encoder push button to view the current firmware version. To update the system firmware, use the encoder push button next to **Update**.

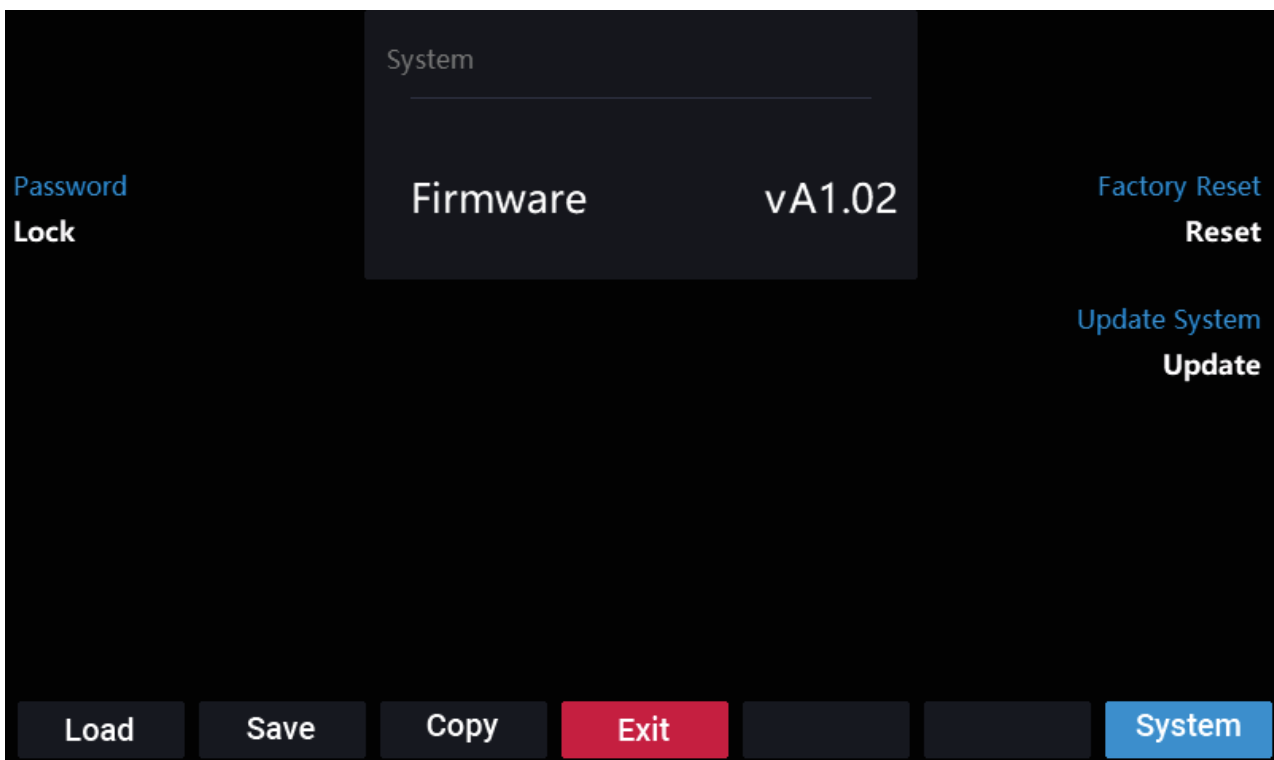

Factory Reset

Select **Factory Reset** using the corresponding encoder push button. This will reset all channel parameters, effect settings, and System settings to factory default settings.

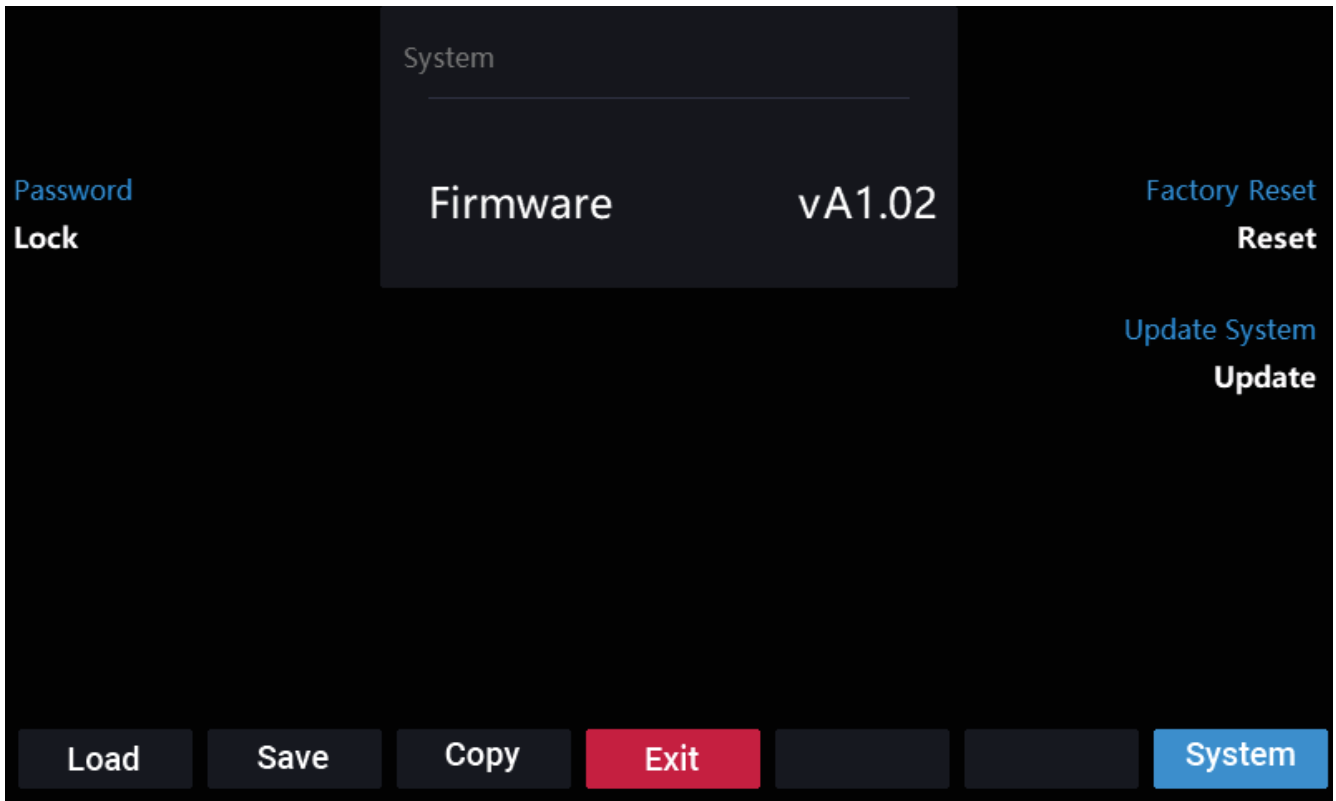

If no sound is heard from your speakers:

- Make sure the input **Gain/Level/Trim**, **Channel Faders**, **Monitor Output** knob, and **Main Fader** are turned up to an appropriate level.
- Make sure microphones, external devices, and speakers are properly connected with working, secure cables.
- If your microphone requires 48V phantom power, ensure **+48** is enabled for the input channel that your microphone is connected to.

If the sound is distorted:

- Try lowering the volume control of your sound source, musical instrument, or microphone.
- Try adjusting the channel EQ if there is too much treble, mid, or bass.
- Turn down the input **Gain/Level/Trim** levels to lower the signal.
- Adjust the overall volume of the mixer using the **Channel Faders** and **Main Fader**.

If a hum is heard when cables are connected:

- Disconnect cables from the input jacks to see if it's a faulty cable.
- Use balanced cabling connections whenever possible.
- Make sure the signal cables are not placed near power cables.
- Connect all audio equipment power cables to outlets which share a common ground.

If there is a high-pitched whistling noise when using microphones, this is probably feedback.

- Point the microphone away from the speaker.
- Turn on the mixer channel's **FBX** setting to try to eliminate the feedback.

If the mixer is not being detected by your computer:

- Connect to a different USB port.
- Avoid using passive (unpowered) USB hubs.
- Try using a different USB cable.
- Disconnect other USB devices.
- Disable Windows sleep and screensaver when recording.

If you are streaming audio and the quality is choppy:

- Ensure you are connected to a USB 2.0 port.
- Ensure your Bluetooth device is within range and not obstructed by walls.

If there is latency when recording:

- Ensure you are connected to a USB 2.0 port.
- Close all other unneeded programs running on the computer.
- Adjust the buffer size in your DAW, in increments of 64.

If you cannot connect your audio device to TMD16 via Bluetooth:

- Have your audio device (e.g., smartphone or tablet) and TMD16 as close together as possible while trying to connect. Make sure both the audio device and TMD16 are unobstructed by walls, furniture, etc.
- Reset the Bluetooth connection on TMD16 to disconnect it from any other audio device and restart the search process. If this does not work right away, power off TMD16 and then power it back on. See the section [Connecting to a Bluetooth® Device](#) for more information.
- Reset the Bluetooth connection on your audio device by turning Bluetooth off and back on. You can usually find this under the Bluetooth menu in the Settings for your phone or other audio device.

If this does not work, and you have connected to TMD16 before, find TMD16 in the list of available or previously connected devices in your audio device's Bluetooth menu, tap the "gear" or "i" icon located next to it and then select **Unpair** or **Forget**. Turn TMD16 off and back on and try pairing again once it reappears in your available devices list.

Note: If TMD16 has been paired to another audio device recently that is still within range, you may need to repeat this process with that audio device to fully disconnect.

Technical Specifications

Specifications are subject to change without notice.

Mic/Line Inputs CH 1-8	
Connector	XLR/TRS Combo
Maximum Input Level	+18 dBu
Gain Range	50 dB
Frequency Response	20 Hz - 20 kHz (+/- 3 dB)
Mic + Stereo Inputs CH 9-12	
Connectors	XLR + (2) TRS
Maximum Input Level	+18 dBu
Gain Range	50 dB
Frequency Response	20 Hz - 20 kHz (+/- 3 dB)
Stereo Inputs 13-14 / 15-16	
Connectors	Dual RCA / 3.5 mm TRS
Gain Range	+/- 20 dB
Frequency Response	20 Hz - 20 kHz (+/- 3 dB)
Max Input Level (for 0.5% THD)	+18 dBu
L-R, Aux 1-3, FX, and Subgroup Outputs	
Connector	(10) XLR
Output Level (0.5% THD)	Fixed +4 dBu
Impedance (unbalanced)	100 Ω
USB (MAIN L-R and CH 15-16)	
Connectors	USB-B and USB-C
Resolution	16-bit / 48kHz
I/O	2x2
Bluetooth CH 13-15	
Wireless Technology	Bluetooth® - Classic Audio
Bluetooth® *	Qualified Against Bluetooth® Core 5.0

Power	
Input	100–240 VAC, 50/60 Hz
Connector	IEC
Physical	
Dimensions (length x width x depth)	4.3" x 15.0" x 16.9" / 110 x 381 x 430 mm
Weight	12 lbs / 5.45 kg

Trademarks & Licenses

Alto Professional is a trademark of inMusic Brands, Inc., registered in the U.S. and other countries.

The *Bluetooth* word mark and logos are owned by the Bluetooth SIG, Inc. and any use of such marks by Alto Professional is under license.

All other product names, company names, trademarks, or trade names are those of their respective owners.

altoprofessional.com