



# SW-300

## Long-Throw Snow Machine User Manual

- ENGLISH



---

**SNOW WIRELESS**  
**SW-300**

---



© 2019 Antari Lighting and Effects Ltd.



# **SNOW WIRELESS** **SW-300**

- ENGLISH -

## **Safety Information**



**Please read the following safety information carefully before operating the machine. Information includes important safety information about installation, usage, and maintenance. Pay attention to all warning labels and instructions in this manual and printed on the machine.**

If you have questions about how to operate the machine safely, please contact your local Antari dealer for help.

- Keep this device dry.
- Always connect to a grounded circuit to avoid risk of electrocution.
- Before connecting the machine to power, always check the voltage indicated on the machine matches to your local AC voltage. Do not use the machine if AC power voltage does not match.
- Disconnect the machine from AC power before servicing and when not in use.
- If the supply cord is damaged, contact your local Antari dealer for replacement.
- This product is for indoor use only! Do not expose to rain or moisture. If fluid is spilled, disconnect AC power and clean with a damp cloth. If fluid is spilled onto electronic parts, immediately unplug the machine and contact your local Antari dealer for advice.
- No user serviceable and modifiable parts inside. Never try to repair this product, an unauthorized technician may lead the machine to damage or malfunction.
- For adult use only. Children being supervised not to play with the machine. Never leave the machine running unattended.
- The machine is not to be used by persons (including children) with reduced physical, sensory or mental capabilities, or lack of experience and knowledge.
- Installed in a well ventilated area. Provide at least 50 cm space around the machine.
- Never add flammable liquid of any kind to the machine.
- Make sure there are no flammable materials close to the machine while operating.
- Only use Antari fluid. Other fluid may lead to heater clog and malfunction.
- If the machine fails to work, unplug the machine and stop operation immediately. Contact your local Antari dealer for .
- Before transporting the machine, make sure the fluid tank is completely drained.

- Smoke fluid may present health risks if swallowed. Do not drink smoke fluid. Store it securely. In case of eye contact or if fluid is swallowed immediately look for medical advice.

## Product Dimension

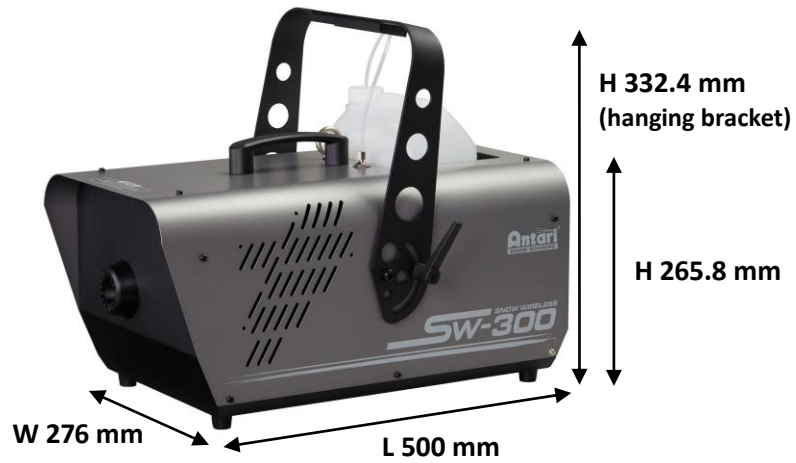

## Product Overview



## Setting Up

**Step 1:** Place the machine on a flat surface and in a suitably large area with at least 50 cm open space around the machine.

**Step 2:** Fill the fluid tank with Antari approved fluid

**Step 3:** Connect the machine to suitably rated power supply. To determine the power requirement for the machine refer to the label on the back of the machine



**Always connect the machine to a protected circuit and ensure it is properly grounded to avoid risk of electrocution.**

**Step 4:** Turn on the machine and wait on till LCD display show “Ready to Snow”

**Step 5:** To start making snow, locate the [VOLUME] button on the control panel, and press the button to start making fog.

**Step 6:** To turn off the machine, press [STOP] button and switch off power.

## Operation

### Control Panel Operation

The machine can be operated with an onboard digital control interface



Button	Function
[MENU]	Scroll through setting menu
▲ [UP]/[TIMER]	Up/Activate Timer function
▼ [DOWN]/[VOLUME]	Down/Activate Volume function
[STOP]	Deactivate Timer/Volume function/Return to Standby

### Control Menu

Interval Set 20s	Set interval from 20 to 2000 seconds
Duration Set 20s	Set duration from 20 to 2000 seconds
Timer Out 100%	Set timer mode output level 0 to 100%
Volume Out 100%	Set volume mode output level 0 to 100%
Fan Out 20%	Set fan output level 20 to 100%
DMX512 Add. 1	Set DMX address 1 to 511
Wireless On	Turn On or Off W-1 wireless control function
Quick StartOFF	Turn On or Off quick start function

### DMX Connector Pin Assignment

The machine provides a 5-pin XLR connector for DMX connection. The diagram below indicates pin assignment information.

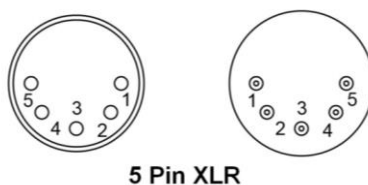

Pin	Function
1	Ground
2	Data-
3	Data+
4	N/A
5	N/A

### **DMX Operation**

*Making the DMX Connection* – Connect the machine to a DMX controller or to one of the machines in the DMX chain. The machine uses a 5-pin XLR connector for DMX connection, the connector is located on the rear of the machine.



*Address Setup* – Use control menu to set DMX address. The machine occupies 2 control channels. The starting address is defined as the first channel from which the machine will respond to the controller. Always double check to make sure there are no overlapping channels in order to control the machine correctly.

### **DMX Channel Function**

Channel 1	DMX Value Range	Function
Snow Output Level	0 – 5	Snow off
	6 – 255	Snow Output 1 – 100%
Channel 2	DMX Value Range	Function
Fan Output Level	0 – 5	Fan 20%
	6 – 255	Fan 21 – 100%

### **RDM Control**

The SW-300 is RDM enabled, allowing control system to configure, monitor and manage. See below table for supported RDM parameters

Value	RDM Parameter ID's	GET Allowed	SET Allowed
0x0001	DISC_UNIQUE_BRANCH		
0x0002	DISC_MUTE		
0x0003	DISC_UN_MUTE		
0x0030	STATUS_MESSAGE	0	
0x0050	SUPPORTED_PARAMETERS	0	
0x0051	PARAMETER_DESCRIPTION	0	
0x0060	DEVICE_INFO	0	
0x0070	PRODUCT_DETAIL_ID_LIST	0	
0x0080	DEVICE_MODEL_DESCRIPTION	0	
0x0081	MANUFACTURER_LABEL	0	
0x0082	DEVICE_LABEL	0	0
0x00C0	SOFTWARE_VERSION_LABEL	0	
0x00E0	DMX_PERSONALITY	0	0
0x00E1	DMX_PERSONALITY_DESCRIPTION	0	
0x00F0	DMX_START_ADDRESS	0	0
0x0400	DEVICE_HOURS	0	
0x1000	IDENTIFY_DEVICE	0	0

### **Wireless Operation**

Wireless remote control W-1 consists of a transmitter equipped with two buttons for output ON and OFF; with an onboard receiver attach to the rear of SW-300



W-1 Wireless Transmitter



Wireless Receiver

Button	Function
[A]	Activate output
[B]	Deactivate output

In an open unobstructed space the effective distance is 50 meters, the effective distance depending on obstacle level is 10-25 meters.

### **Registering transmitter**

The transmitter can be paired or deleted from the receiver. Each receiver can pair up to 5 transmitters. Follow the steps below to pair or delete a transmitter from the receiver.

**Step 1:** Power on SW-300 Snow Machine

**Step 2:** When “Wireless Setup” shown on display, press button [A] on transmitter

**Step 3:** Once display show “Wireless Setup Ok”, registering process has completed.

### **IMPORTANT NOTE:**

- *Wireless register menu will only be shown when Wireless is turn ON*
- *The machine allows registering transmitter within 15 seconds. When exceed 15 seconds power machine off and on again to complete the process.*

### **Transmitter battery replacement**

If the effective distance appears to be decreased, it is possible the battery level is low and require replacement. In order to replace the battery, undo the three screws on the back of transmitter to release the cover. Replace with same type and specification of battery which is 12V

### **SC-3 Wire Remote Operation (Optional)**



Wired remote control module SC-3 enable to control machine from a remote location. With three push buttons and two rotary knobs for activate/deactivate, prime and output level adjustment

<b>Button/Knob</b>	<b>Function</b>
[TOP LEFT KNOB]	Adjust pump output level
[TOP RIGHT KNOB]	Adjust blower output level
[LEFT BUTTON]	Max output on pump and blower
[CENTER BUTTON]	Turn On/Off SC-3 remote
[RIGHT BUTTON]	Max output on blower

**IMPORTANT NOTE:**

[LEFT BUTTON] is meant for priming use, with a new tank of fluid or refill the fluid may not pump properly due to airlock in the pipeline, use this function to activate pump at maximum output, the [RIGHT BUTTON] is used when needed to clean out residue at the tip of output nozzle. Both of these buttons will overtake output adjustment knobs.

**Physical Installation**

**Important**

- Use supplied mounting bracket or rigging clamp to install nozzle.
- Make sure installation location, fastening connecting, and rigging hardware can hold at least 10 times the weight of the nozzle.
- Make sure no combustible or flammable materials are nearby.
- Secure nozzle with an approved safety cable that can hold at least 10 times the weight of nozzle.
- Make sure nozzle is installed in a well ventilated area.
- Consider nozzle replacement and routine maintenance access when selecting installation location.

**Adjustable Mouting Bracket**

Adjust mounting bracket by loosening screws, set the nozzle to desired angle and tighten the screw to finish adjustment. Illustration below demonstrates how to adjust mounting bracket.

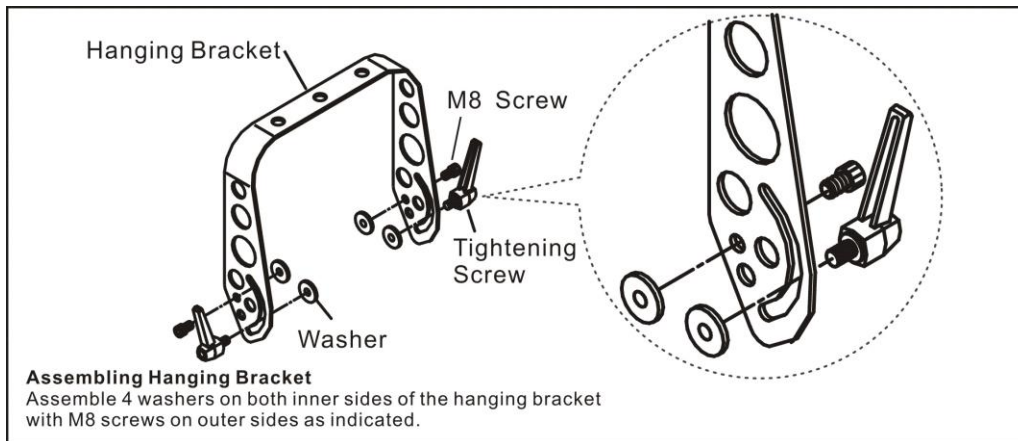

## Fluid



### SL-N (New Formula)

- Artificial snowflake produced by SL-H is the finest (smallest in size and lightest in weight) among Antari snow fluids, which is the driest and leaves least wet residue when it falls on the ground.
- Recommended for outdoor operation.



### SL-H

- SL-H can produce higher snow volume than the snow effects from SL.
- Good for outdoor operation.

## Service and Maintenance

- Do not allow the machine to become contaminated.
- Remove dust from air vents with air compressor, vacuum or a soft brush.
- Only use a damp cloth to clean the casing.
- Before storing run distilled water through the system to help avoid condensing the pump or heater.
- It is recommended to run the machine on a monthly basis in order to achieve best performance and output condition.
- Excessive dust, liquid and dirt built up will degrade performance and cause overheating.
- Before storing away after operation, pump pure water through the system for at least 1 to 2 minutes. This will help clean out the remaining snow fluid and prevent pump from malfunction on next usage.

## Technical Specifications

<b>- Input voltage</b>	US model : AC 100-120V, 50/60Hz 7.5A EU model : AC 220-240V, 50/60Hz 3.8A
<b>-Rated power</b>	880 W
<b>-Fluid consumption</b>	280 ml/min (100% output)
<b>-Fluid tank capacity</b>	5 Liters
<b>-Compatible fluid</b>	Antari SL-N Snow Foam Fluid Antari SL-H Snow Foam Fluid
<b>-Ambient temp/ range</b>	5°C - 40°C
<b>-Control</b>	DMX 512 , Timer , Manual , Wireless
<b>-DMX channels</b>	2 channels
<b>-Connection</b>	IEC (POWER) XLR 5-pin (DMX)
<b>-Optional accessories</b>	SC-3 Cable Remote
<b>-Dimension</b>	L 500 W 276 H 265.8 mm (H 332.4mm (hanging bracket))
<b>-Weight</b>	11.5 kg

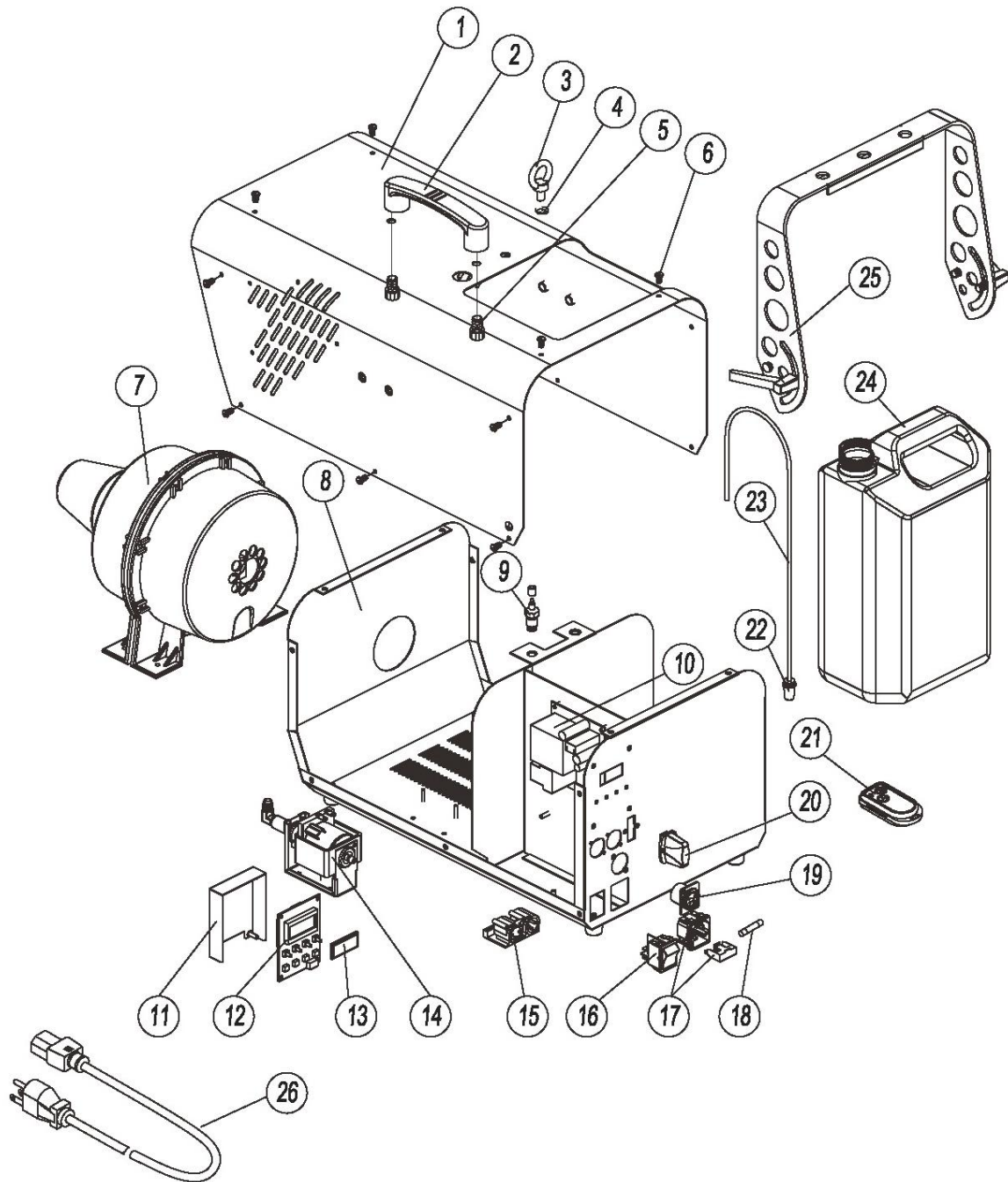

**SNOW WIRELESS**  
**SW-300**

- |   |                      |   |                                             |
|---|----------------------|---|---------------------------------------------|
| ① | Steel Case/Cover     | ⑮ | P.C Board(DMX)include 3pin Socket           |
| ② | Handle               | ⑯ | Rocker Switch/Power                         |
| ③ | Safety Ring M8 Screw | ⑰ | Power Inlet Socket& Fuseholder              |
| ④ | Washer               | ⑱ | Fuse T10A/250V                              |
| ⑤ | M8x12L Screw         | ⑲ | Control Outlet Socket(4 Pin XLR for remote) |
| ⑥ | M4x8L Screw          | ⑳ | W-1 Wireless Receiver                       |
| ⑦ | Air Blower           | ㉑ | W-1 Wireless Controller                     |
| ⑧ | Steel Case/Base      | ㉒ | Filter 4L                                   |
| ⑨ | Adaptor With Nut     | ㉓ | Pu Tube 4MM                                 |
| ⑩ | Main P.C Board       | ㉔ | Tank                                        |
| ⑪ | Steel Case/Cover     | ㉕ | Hanging Bracket(Group)                      |
| ⑫ | Control P.C Board    | ㉖ | Cable & Plug                                |
| ⑬ | L.C.D COVER          |   |                                             |
| ⑭ | Pump                 |   |                                             |







---

# **SW-300** SNOW WIRELESS

---



C08SW3001