

# CLASSIC CANTABILE

## UP-1 Digitalpiano



## Bedienungsanleitung / User manual

Version: 07/2025

## **WEEE-Erklärung (Waste of Electrical and Electronic Equipment)**

Ihr Produkt wurde unter Verwendung hochwertiger Materialien und Komponenten entwickelt und hergestellt, die recycelbar und wiederverwendbar sind. Dieses Symbol bedeutet, dass elektrische und elektronische Geräte am Ende ihrer Lebensdauer vom Hausmüll getrennt entsorgt werden müssen.

Bitte entsorgen Sie dieses Gerät bei Ihrer örtlichen kommunalen Sammelstelle oder im Recycling-Center.

Bitte helfen Sie mit, die Umwelt zu schützen, in der wir alle leben.

Alle technischen Daten und Erscheinungsbilder können ohne vorherige Ankündigung geändert werden. Alle Angaben waren zum Zeitpunkt der Drucklegung korrekt. Die Musikhaus Kirstein GmbH übernimmt keine Gewähr für die Richtigkeit oder Vollständigkeit der in diesem Handbuch enthaltenen Beschreibungen, Fotos oder Aussagen. Gedruckte Farben und Spezifikationen können geringfügig vom Produkt abweichen. Produkte der Musikhaus Kirstein GmbH werden nur über autorisierte Händler vertrieben. Distributoren und Händler sind keine Vertreter der Musikhaus Kirstein GmbH und nicht befugt, die Musikhaus Kirstein GmbH in irgendeiner Weise, sei es ausdrücklich oder durch schlüssiges Handeln, rechtlich zu binden.

 **KIRSTEIN.de**

**Musikhaus Kirstein GmbH**

**Bernbeurener Str. 11**

**86956 Schongau – Germany**

**Telefon: 0049-8861-909494-0**

**Mail: [info@kirstein.de](mailto:info@kirstein.de)**



## Appendix

### Voice-Liste

| No. | Voice Name       | No. | Voice Name         |
|-----|------------------|-----|--------------------|
| 1   | Grand Piano      | 21  | Cello              |
| 2   | Grand Piano/Wide | 22  | Orchestral Harp    |
| 3   | Bright Piano     | 23  | String Ensembles 1 |
| 4   | Electric Grand   | 24  | String Ensembles 2 |
| 5   | Honky Tonk       | 25  | Choir Aahs         |
| 6   | Harpsichord      | 26  | Trumpet            |
| 7   | E.Piano 1        | 27  | Trombone           |
| 8   | E.Piano 2        | 28  | Tuba               |
| 9   | Clavi            | 29  | French Horn        |
| 10  | Drawbar Organ    | 30  | Soprano Sax        |
| 11  | Percussive Organ | 31  | Alto Sax           |
| 12  | Rock Organ       | 32  | Tenor Sax          |
| 13  | Church Organ     | 33  | Baritone Sax       |
| 14  | Reed Organ       | 34  | Flute              |
| 15  | Accordion        | 35  | Pan Flute          |
| 16  | Tango Accordion  | 36  | Sitar              |
| 17  | Guitar & Bass 1  | 37  | Banjo              |
| 18  | Guitar & Bass 2  | 38  | Shamisen           |
| 19  | Bass & Vibra     | 39  | Koto               |
| 20  | Violin           | 40  | Bag Pipe           |

### Song-Liste

| No. | Song-Name                | No. | Song-Name         |
|-----|--------------------------|-----|-------------------|
| 1   | The Entertainer          | 46  | Four Little Swans |
| 2   | Rialto Ripples (Rag)     | 47  | Progress          |
| 3   | Neapolitan Song          | 48  | Eclogue           |
| 4   | Waltzes                  | 49  | The Limpid Stream |
| 5   | Turkish March            | 50  | Brave Cavalier    |
| 6   | Schos Doll's Dance No. 2 | 51  | The Chatterbox    |
| 7   | Minuet In D Major        | 52  | Tarantella        |
| 8   | Inquietude               | 53  | Frankness         |
| 9   | Italian Polka            | 54  | Tender Grieving   |
| 10  | Moment Musical           | 55  | The Farewell      |
| 11  | Prelude In C-Sharp Major | 56  | The Chase         |

|    |  |    |                                 |
|----|--|----|---------------------------------|
| 12 | The Happy Farmer                         | 57 | Habanera                        |
| 13 | The Rag-Time Dance                       | 58 | Prelude In C Major              |
| 14 | Piano Sonata In C Major, K.330. III      | 59 | Piano Sonata In C Major, K.545. |
| 15 | Mazurka                                  | 60 | Piano Sonate op.49-2            |
| 16 | Prelude In E Major                       | 61 | Serenade                        |
| 17 | Piano Sonata In A Major, K.331. I        | 62 | Prelude D-Dur/D major BWV936    |
| 18 | Waltz For Piano In G-Sharp Minor         | 63 | Prelude C-Dur/C major BWV924    |
| 19 | Gavotte                                  | 64 | Toys Ragtime                    |
| 20 | L' Arabesque                             | 65 | Maple leaves Ragtime            |
| 21 | Austria Variation                        | 66 | Chicken pecking Ragtime         |
| 22 | Schos Doll's Dance No. 7                 | 67 | Pretty girl Ragtime             |
| 23 | To A Wild Rose                           | 68 | Menuett G dur 3                 |
| 24 | Gavotte I                                | 69 | Perpetuum mobile                |
| 25 | Waltz                                    | 70 | The Nightingale was singing     |
| 26 | Minuet In G Major (BWV Anh. 116)         | 71 | Gipsy Rondo                     |
| 27 | Innocence                                | 72 | Fountain                        |
| 28 | Tchaikovsky Waltz                        | 73 | Fur Elise                       |
| 29 | Salut d' Amour                           | 74 | Prelude F-Dur/F major BWV927    |
| 30 | Barcarolle                               | 75 | Prelude d-Moll/D minor BWV935   |
| 31 | Robot Doll                               | 76 | Prelude e-Moll/E minor BWV938   |
| 32 | Consolation                              | 77 | Prelude G-Dur/G major BWV936    |
| 33 | 2-Part Invention #13 In A Minor.B.W. Iii | 78 | Dove                            |
| 34 | Minuet In G Major (BWV Anh. 114)         | 79 | Knight                          |
| 35 | Barcarolle                               | 80 | Ave Maria                       |
| 36 | Norwegian Dance No.2                     | 81 | Prelude G-Dur/G major BWV902a   |
| 37 | Moseta Dance                             | 82 | Menuett G dur 4                 |
| 38 | The Small Gathering                      | 83 | The two part inventions 1       |
| 39 | The Return                               | 84 | The two part inventions 2       |
| 40 | The Wagtail                              | 85 | Gavotte                         |
| 41 | Bulie Dance                              | 86 | The angels singing              |
| 42 | Tender Blossom                           | 87 | Minuet                          |
| 43 | Grace                                    | 88 | Lyrical Rondo                   |
| 44 | Cherish The Memories                     | 89 | Swallow                         |
| 45 | Chopsticks                               | 90 | Minute Waltz                    |

Die Inhalte der Voice-Liste und Song-Liste sind ohne Gewähr. Die Musikhaus Kirstein GmbH behält sich vor einzelne Klangfarben und Musikstücke ohne Angabe von Gründen abzuändern oder ersatzlos zu streichen.

# CLASSIC CANTABILE

## UP-1 Digital Piano



## User manual

Version: 07/2025

Thank you for choosing this product. To ensure that you are fully satisfied with this product, carefully read and understand this manual before using this instrument. Keep this manual in a safe place. The operating instructions must be passed on to all subsequent users.



Observe operating instructions!



**WARNING**

The **WARNING** signal word identifies hazards that, without precautions, could result in serious injury.



**NOTE**

The signal word **NOTE** indicates general precautions that should be observed when handling the product.



**NOTE**

Images and screen images in this manual may differ slightly from the actual product's appearance, as long as it does not adversely affect the technical characteristics and safety of the product.



**NOTE**

All personal phrasing in this manual should be considered gender neutral.

These operating instructions apply to responsible persons and users who have been supervised by a person responsible for their safety or instructed in the operation of the device and who have proven to be able to handle the device.



**WARNING**

**Children should be supervised to ensure that they do not use this device as a toy.  
Never allow children to play unattended with the packaging material.**



**WARNING**

**Danger of property damage! We are not liable for accidents that occur as a result of non-observance of the safety instructions or due to incorrect handling.**

All information in this manual has been checked to the best of our knowledge and belief. However, neither author nor publisher can be held liable for any damage related to the use of this manual.

Other product, brand and company names mentioned herein may be the trademarks of their respective owners. Compliance with all applicable copyright laws is the responsibility of the user of this document.

 **WARNING**

**Caution**

Please observe the following basic information in order not to endanger yourself or others and to avoid damage to external devices.

 **NOTE**

**Warning**

Do not disassemble the instrument and do not modify it. This could result in electric shock. Entrust a specialist workshop with any necessary service and maintenance or contact your dealer.

If you notice that the power cord is showing signs of wear, the unit shows malfunctions, burns, smells or smokes, unplug the power cord immediately and have a technician repair it. Before you clean the instrument, you should disconnect it from the mains power.

Always place the instrument on a level, stable surface to ensure a secure footing.

Do not use the instrument in a damp or wet environment.

Do not place vessels that are filled with liquids on the instrument, such as vases, glasses or bottles.

Do not place small objects on it that could slip in, such as hairpins, sewing needles or coins.

Do not place burning candles on the instrument.

 **NOTE**

**Precautions**

To avoid damage to the instrument, do not place it in places with high temperatures or dust, do not place it next to an air conditioner and avoid direct sunlight.

Do not place the instrument near other electrical equipment to avoid interference.

Do not use force when handling the instrument or place heavy objects on it.

Disconnect the instrument from the power if you are not going to use it for a long time. To disconnect the device from the mains, pull the plug, not the cable. Please handle the power cable with care. It should not be near radiators, you should not place heavy objects on it and move it so that people can not step on it or fall over it.

Please note that continuous high volume can permanently damage your hearing. Adjust the volume carefully.

 **WARNING**

**Power adapter**

Please connect the supplied power adapter to a power outlet with the correct voltage. Do not connect it to mains voltages other than those for which the instrument is intended. Unplug the power cord if you are not going to use the product for a long time or if there is upcoming a thunderstorm.

© 2024

These operating instructions are protected by copyright. The reproduction of these operating instructions, even in part, is only permitted with the approval of Musikhaus Kirstein GmbH. The same applies to the reproduction or copying of images, even in modified form.

## Contents

|   |           |
|---|-----------|
| <b>Assembly</b> .....   | <b>6</b>  |
| <b>Front connection panel</b> .....                                     | <b>9</b>  |
| USB to Host .....   | 9         |
| USB to Device.....  | 9         |
| Phones.....   | 9         |
| Mic In / AUX .....  | 10        |
| AUX .....   | 10        |
| <b>Control elements</b> .....   | <b>11</b> |
| Power switch and knobs for volume, brilliance, and tempo.....           | 11        |
| Power .....   | 11        |
| Overall volume (MASTER).....  | 11        |
| Microphone volume (MIC).....  | 11        |
| Piano lid simulation (BRILLIANCE) .....                                 | 11        |
| Speed (TEMPO).....  | 12        |
| Control unit for metronome, song playback, and recording function ..... | 12        |
| Metronome (METRO) .....   | 12        |
| Recording (REC, LEFT, RIGHT, START/STOP).....                           | 12        |
| 1. Simple recording to the internal memory (MIDI) .....                 | 12        |
| 2. Combined recording to internal memory (MIDI).....                    | 13        |
| 3. Recording to an external storage medium (mp3).....                   | 13        |
| Song playback (SONG, LEFT, RIGHT, START/STOP).....                      | 13        |
| USB memory (USB, START/STOP) .....                                      | 14        |
| Control panel for voice selection and other functions .....             | 14        |
| Selecting the tone color (VOICE) .....                                  | 14        |
| Demo of the respective tone (VOICE DEMO) .....                          | 14        |
| Combining two tones (DUAL) .....  | 15        |
| Combining two tones (SPLIT) .....                                       | 15        |

|   |           |
|---|-----------|
| Splitting the keyboard (TWINOVA) .....  | 15        |
| Piano mode (PIANO) .....  | 16        |
| Function menu (FUNCTION) .....  | 16        |
| 1. General settings .....   | 16        |
| Transpose (TRANSPPOSE) .....  | 16        |
| Octave (OCTAVE R1, OCTAVE R2, OCTAVE L) .....   | 16        |
| Touch sensitivity (TOUCH) .....   | 16        |
| Volume levels (VOLUME R1, VOLUME R2, VOLUME L, VOLUME MUSIC)<br>.....                             | 16        |
| Metronome time signature (METRONOME) .....  | 16        |
| Speaker EQ settings (SPEAKER EQ).....   | 16        |
| String resonance (STRING RES.).....   | 17        |
| Effects (REVERB TYPE, REVERB LEVEL, CHORUS TYPE, CHORUS<br>LEVEL, MIC FX TYPE, MIC FX LEVEL)..... | 17        |
| Audio player playback mode (SONG LOOP) .....  | 17        |
| Deactivating the internal sound generator (LOCAL).....  | 17        |
| Table - general settings.....   | 17        |
| 2. Additional settings .....  | 18        |
| MIDI Out Channels (MIDI OUT CH).....  | 18        |
| Auto power off (POWER OFF).....   | 18        |
| Time and date setting (YEAR, MONTH, DAY, HOUR, MINUTE) .....                                      | 18        |
| Reset (SYSTEM RESET) .....  | 18        |
| Table - Additional settings .....   | 19        |
| <b>Connecting a computer or smart device.....</b>   | <b>19</b> |
| <b>Troubleshooting .....</b>  | <b>20</b> |
| <b>Product specifications .....</b>   | <b>21</b> |
| <b>Appendix .....</b>   | <b>23</b> |
| Voice list.....   | 23        |
| Song list .....   | 23        |

## Assembly

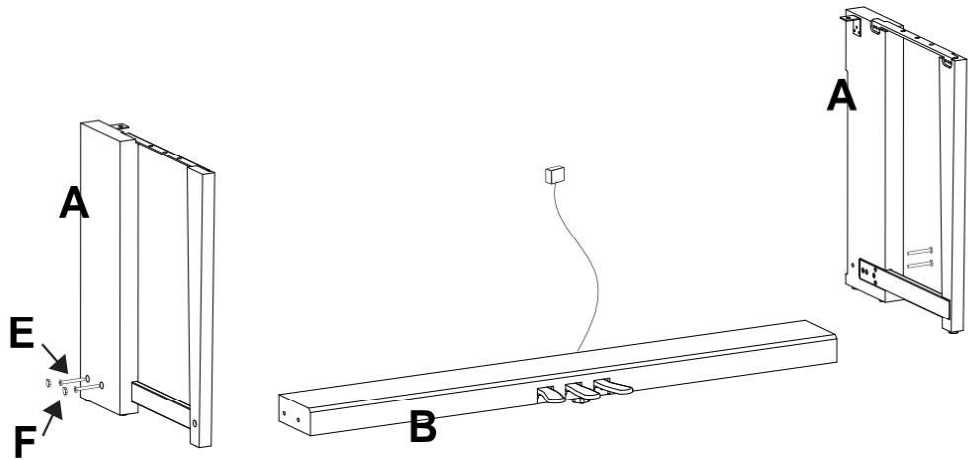

First attach the two side panels **A** to the pedal bar **B** using the long screws **E** and cover the screw openings with the plastic caps **F**.

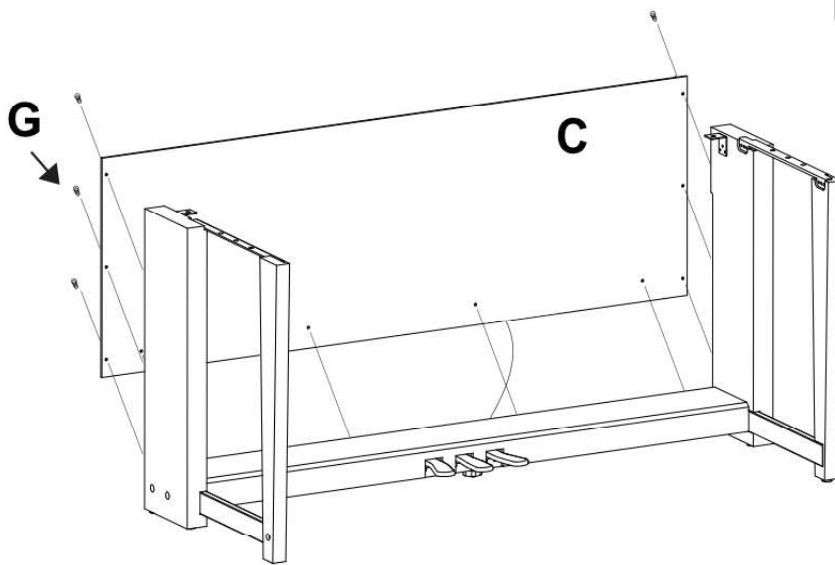

Now attach the back panel **C** to the base frame and secure it to the side panels and the pedal bar using the short, pointed screws **G**.



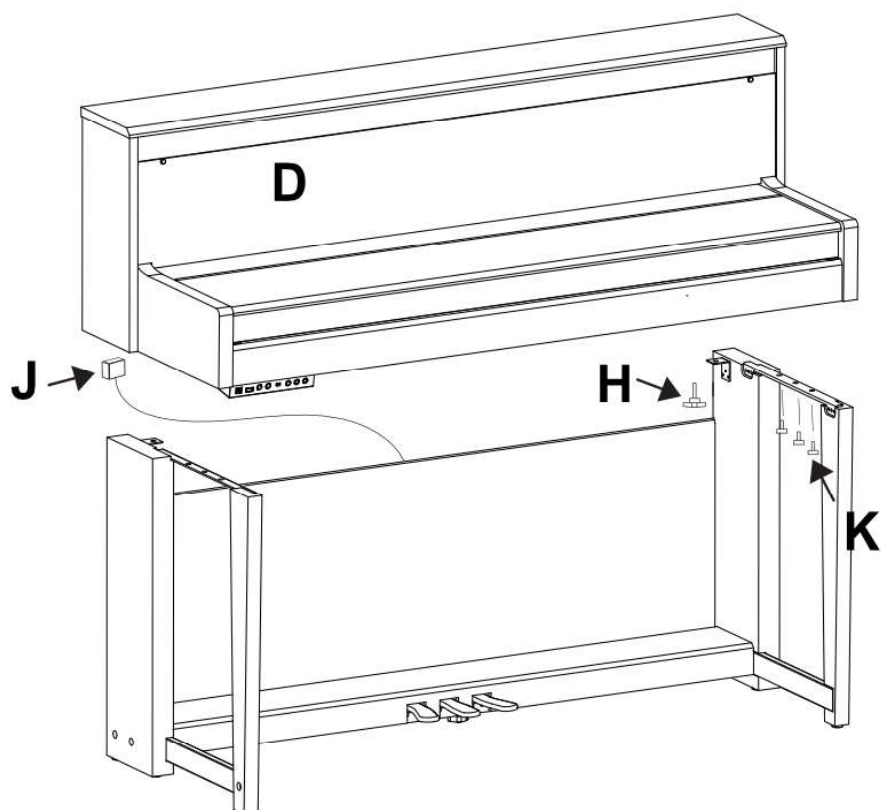

Carefully place the play table **D** on the base. Ask someone to help you with this and be careful of your fingers. Secure the keyboard securely to the rear metal brackets using the two plastic head screws **H** and to the mounting strip on the base frame using the six short screws **K**. It may be helpful to first screw all screws in by hand and then tighten them once all screws are in position.



Now connect the pedal cable **J** to the socket on the underside of the piano and plug the power supply's barrel plug into the power supply socket on the back of the instrument.

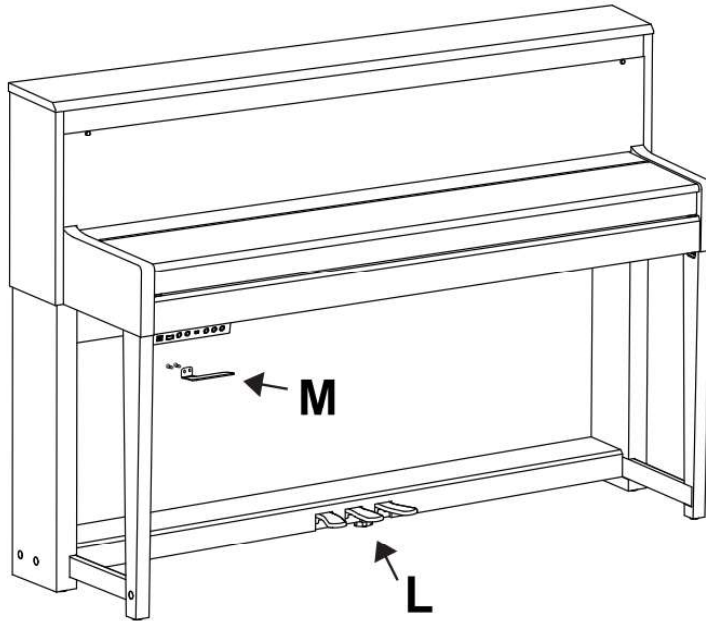

If desired, attach the headphone holder **M** to the back of the connection box. The two holes for the mini screws supplied with the holder are easy to feel.

Now place the piano in its intended location.

**Caution:** Now turn the support screw **L** on the pedal unit all the way out until it touches the floor.

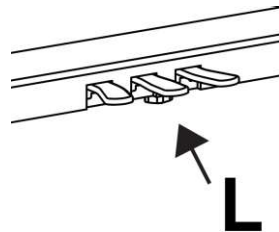

► It may be useful to keep the packaging materials in case the instrument needs to be transported to a distant location.

## Front connection panel

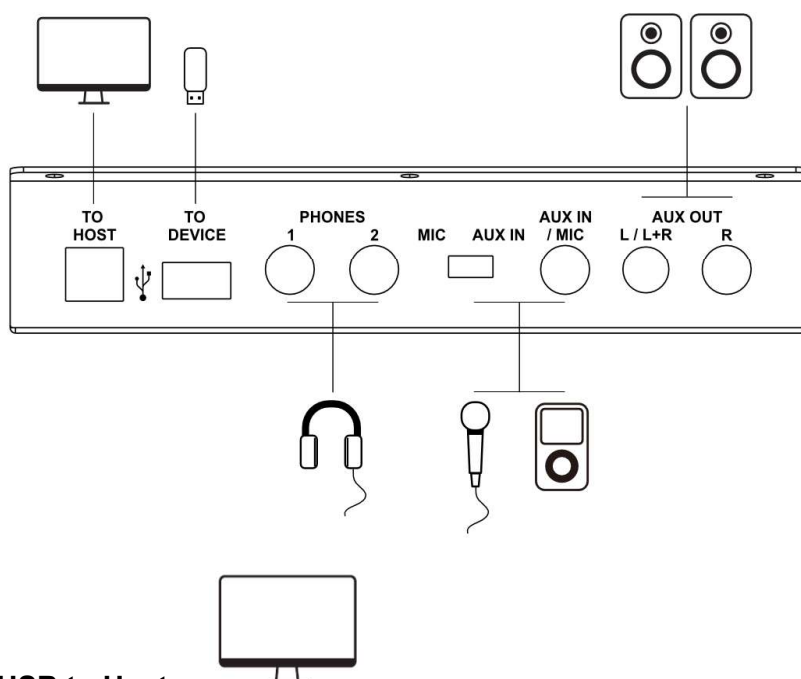

### USB to Host

You can connect your piano to a computer using a USB A-to-B cable via the USB to Host socket.

### USB to Device



You can use a USB stick to record songs in mp3 format or to play songs in mp3 or MIDI format. USB storage devices from 2-128GB are supported. The USB stick must be formatted in FAT32. Access is via the root directory. Do not create any subfolders.

### Phones



Both headphone jacks can be used simultaneously. When headphones are connected, the instrument's speakers are automatically muted. Caution: Ensure that the volume is set to an appropriate level. Excessive volume or prolonged use of headphones can cause hearing damage.

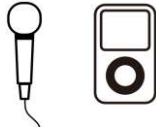

### **Mic In / AUX In**

The **Mic In** input allows you to play a dynamic microphone through the speakers of your piano. To do this, set the **selector switch to the MIC position**. Caution: Depending on the quality of the microphone, feedback may occur. Avoid excessive volume and do not point the microphone towards the speakers of the piano.

The **AUX In** input allows you to play music from an external music source through your piano's speakers. To do this, set the **selector switch to the AUX IN position**.

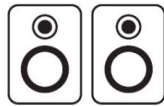

### **AUX Out**

You can use the AUX Out connection to connect your piano to a music amplifier.

## Control elements

### Power switch and knobs for volume, brilliance, and tempo

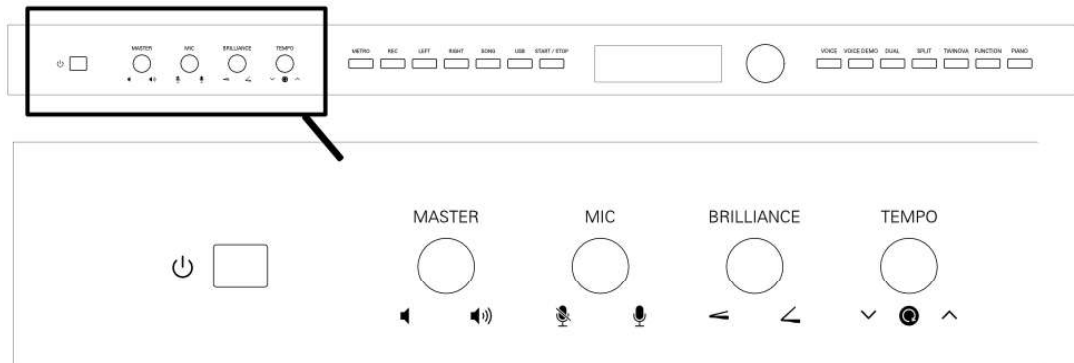

### Power

The power switch turns your instrument on. Please turn off your instrument when not in use to save energy.

**This instrument has an auto power off function. To save energy, the piano will turn itself off if it is not used for a long period of time.**

### Overall volume (MASTER)

This knob lets you adjust the volume of your piano. Always turn this knob to zero before using your instrument and before connecting peripheral devices (headphones, microphone, USB device/stick, external amplifier, external player, recording device), and then adjust the volume to the desired level.

### Microphone volume (MIC)

This knob lets you adjust the volume of a connected microphone. Always turn this knob to zero before connecting a microphone, then adjust the volume to the desired level.

### Piano lid simulation (BRILLIANCE)

This control simulates the opening and closing of the piano lid on a real concert grand piano. This knob lets you adjust the treble of the sound reproduction. Turn the knob to the left for a warmer sound and to the right for a cooler, more brilliant sound.

## Speed (TEMPO)

Turn this knob to adjust the tempo.

Press the knob briefly to return to the original tempo.

Press and hold the knob to switch from the tempo display in BPM (30-280 beats per minute) to the classic tempo notation (Grave to Prestissimo) on the display. The tempo display then automatically returns to the standard display (BPM).

## Control unit for metronome, song playback, and recording function

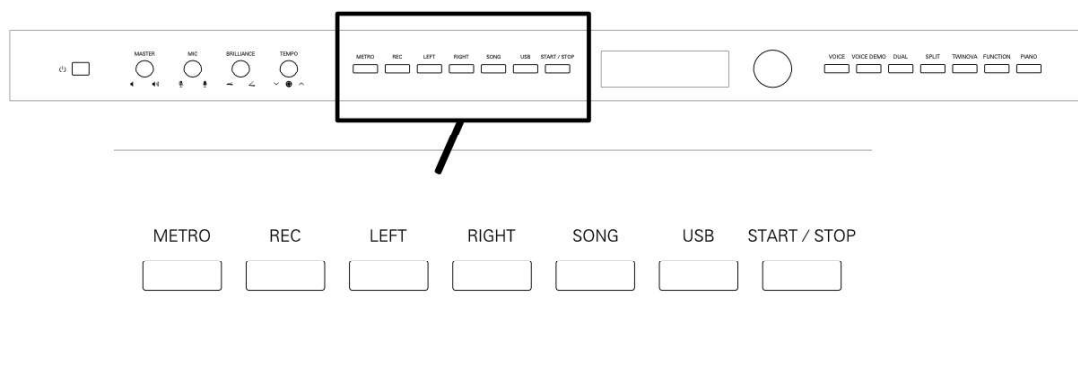

## Metronome (METRO)

Press the METRO button to start the metronome. Press the METRO button again to stop the metronome.

The speed of the metronome is set using the TEMPO knob (see Speed (TEMPO)).

The time signature of the metronome can be changed in the function menu if necessary (see Function menu (FUNCTION)).

The metronome signal is not output via the AUX OUT and USB-to-Host jacks.

The metronome signal is not recorded in recording mode.

## Recording (REC, LEFT, RIGHT, START/STOP)

### 1. Simple recording to the internal memory (MIDI)

The piano has an internal memory that can store one user song in MIDI format. To record a song as a MIDI file in the internal memory, make sure that no USB storage device is inserted in the instrument's USB slot. Press the REC button to put the instrument in recording mode. If there is already a recording in memory, the message "Overwrite User Song?" appears on the display. Follow the instructions on the display to cancel the recording or to release the saved song for overwriting. The instrument is ready to record when the "Rec" indicator flashes on the display and the metronome starts (the metronome click is for your reference only and is not recorded). Now select

the desired metronome speed by turning the TEMPO knob or deactivate the metronome by pressing the METRO button. Then start recording by pressing the START/STOP button or, alternatively, by playing directly on the keyboard. During recording, the "Rec" indicator on the display lights up continuously. Stop recording by pressing the START/STOP button.

Once the recording is complete, the piano switches to song playback mode. "USER SONG" appears on the display. Press the START/STOP button to play back the song.

## **2. Combined recording to internal memory (MIDI)**

It is possible to record a combination of your piano playing and a song stored on the piano (except for the user song) and save it as a user song. To save a combined recording as a MIDI file in the internal memory, make sure that no USB storage device is inserted in the USB slot of the instrument. Now select a title from the song memory as described in the Song playback section. If necessary, you can deactivate the left or right track of the song, for example to record the right hand of a piano piece while being accompanied by the left hand from the song memory. Press the REC button to put the instrument in record mode. If there is already a recording in memory, the message "Overwrite User Song?" appears on the display. Follow the instructions on the display to cancel the recording or to enable the stored song to be overwritten. The instrument is ready to record when the "Rec" indicator flashes on the display and the metronome starts (the metronome click is for your reference only and is not recorded). Now select the desired song speed by turning the TEMPO knob. If you want to record without the metronome, you can turn it off by pressing the METRO button. Then start recording by pressing the START/STOP button or by playing the piano. While recording, the "Rec" indicator on the display will light up continuously. Stop recording by pressing the START/STOP button.

Once recording is complete, the piano switches to song playback mode. "USER SONG" appears on the display. Press the START/STOP button to play back the song.

## **3. Recording to an external storage medium (mp3)**

The piano can record audio data in mp3 format if a USB stick (2GB-128GB formatted in FAT32 format) is inserted into the USB-to-Device port of the instrument. Press the REC button to put the instrument in recording mode. If the USB stick is not formatted in FAT32 format, recording is not possible. The message "Unsupported USB format, Format USB flash drive?" appears on the display. In this case, follow the instructions on the display or remove the USB stick from the socket. The recording is ready when the "Rec" indicator flashes on the display and the metronome starts (the clicking of the metronome is for your orientation only and is not recorded). Now select the desired song speed by turning the TEMPO knob. If you want to record without the metronome, you can deactivate it by pressing the METRO button. Then start recording by pressing the START/STOP button or, alternatively, by playing directly on the keyboard. During recording, the "Rec" indicator on the display lights up continuously. Stop recording by pressing the START/STOP button.

Once recording is complete, the piano switches to USB song playback mode. "SONG x" appears on the display. Press the START/STOP button to play back the song.

With this type of recording, the signal from the AUX/MIC jack can also be recorded in addition to the performance on the keyboard.

## **Song playback (SONG, LEFT, RIGHT, START/STOP)**

Press the SONG button to access the song selection screen. Select the desired song using the rotary knob to the right of the display.

Press Start/Stop to start or stop playback of the selected song.

The speed of the song can be adjusted using the TEMPO knob (see Speed (TEMPO)).

Use the LEFT and RIGHT buttons to switch the left and right tracks (left/right hand) of the song on or off independently. If one of the two tracks is deactivated, this is indicated on the display by "L-OFF" or "R-OFF."

### USB memory (USB, START/STOP)

To play songs from USB storage, press the USB button. Then use the rotary knob to the right of the display to select the desired song and start it with the START/STOP button. Press this button again to stop song playback.

If the USB stick is not recognized correctly and/or no songs are displayed, make sure that there are files in mp3 or MIDI format in the root directory of the stick and that the stick has the correct size and formatting (2-128MB, FAT32). The stick can be formatted to the correct FAT32 format directly on the piano. To do this, press the REC button. If the stick is formatted in a format other than FAT32, the message "Unsupported USB format, Format USB flash drive?" appears on the display. In this case, follow the instructions on the display. Caution: formatting will delete all data stored on the stick.

### Control panel for voice selection and other functions

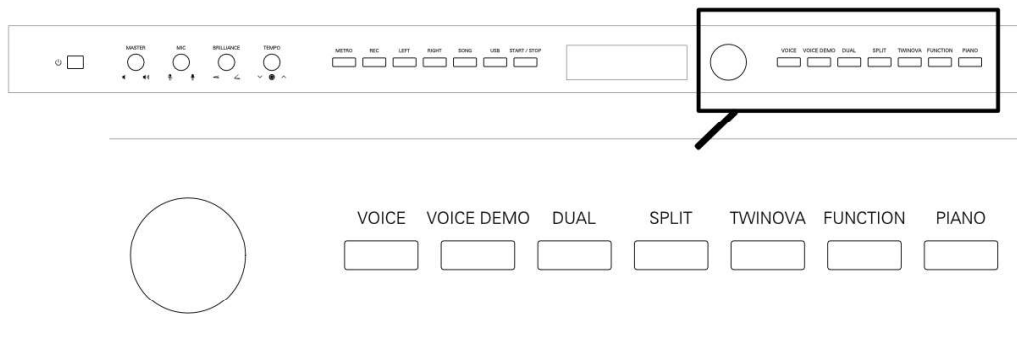

### Selecting the tone color (VOICE)

Press the VOICE button to access the menu for selecting the tone. After pressing the VOICE button, the name and number of the currently selected tone appear on the display. Now turn the rotary control to the right of the display to switch to a different tone.

In Dual and Lower mode, press the Voice button several times to select the respective tone (R1, R2, L).

### Demo of the respective tone (VOICE DEMO)

Press the VOICE DEMO button to play a demo of the currently selected tone.

### **Combining two tones (DUAL)**

To play two tones simultaneously, press the DUAL button. When you play the keyboard, two tones will sound simultaneously. These tones are referred to as R1 (main voice) and R2 (layer voice). By pressing the VOICE button several times, you can select the two tones separately and change them using the rotary knob to the right of the display. R1 or R2 is shown on the display.

The volumes of the tones can be adjusted proportionally in the function menu. See: Function menu (FUNCTION)

Press the DUAL button again to exit this function.

### **Combining two tones (SPLIT)**

To assign different tones to the left and right sides of the keyboard, press the SPLIT button. When you play the keyboard, a different tone will sound on the left side of the keyboard than on the right side. These tones are referred to as L (lower voice) and R1 (main voice). By pressing the VOICE button several times, you can select the two tones separately and change them using the rotary knob to the right of the display. L or R1 is shown on the display.

The volumes of the tones can be adjusted proportionally in the function menu.  
See: Function menu (FUNCTION)

The position on the keyboard where the lower voice and the main voice meet is called the split point (default F#3). Hold down the SPLIT button and turn the dial to the right of the display to move the split point, or press any key on the keyboard while holding down the SPLIT button to set the split point at that position.

Press the SPLIT button again to exit this function.

**The split and dual functions can be combined.**

### **Splitting the keyboard (TWINOVA)**

Press the TWINOVA button to activate the Twinova function. This function divides the piano keyboard into two equal halves. Now two piano players (e.g., teacher and student) can use the instrument at the same time. Pressing the TWINOVA button once divides the keyboard at the F#4 key (center of the keyboard). Pressing the TWINOVA button again shifts the division to the E3 key (division 1/3-2/3).

In this mode, not all pedal functions are available. In TWINOVA mode, all three pedals of the piano function as sustain pedals, with the left pedal applied exclusively to the left half of the keyboard and the right pedal applied exclusively to the right half of the keyboard. The middle pedal also has a sustain function, but it affects both halves of the keyboard.

Functions such as DUAL and SPLIT are not available in TWINOVA mode.

To exit TWINOVA mode, press the VOICE button.

## **Piano mode (PIANO)**

Press the PIANO button to switch to Piano mode. All parameter settings of the instrument are optimized for piano playing in this mode.

The DUAL, SPLIT, and other functions are not available in this mode.

To exit Piano mode, press the VOICE button.

## **Function menu (FUNCTION)**

### **1. General settings**

Press the FUNCTION button to access the function menu.

Press the FUNCTION button repeatedly to scroll through the individual functions.

You can now change the setting for the selected function by turning the rotary knob to the right of the display.

The general settings include the following functions:

#### ***Transpose (TRANPOSE)***

This function allows you to shift the pitch of the instrument up or down in semitone steps. This can make it easier to play difficult pieces and to play together with other instruments.

#### ***Octave (OCTAVE R1, OCTAVE R2, OCTAVE L)***

This function allows you to shift the notes of a voice (R1, R2, L) up or down by an octave. This function is useful, for example, when combining multiple voices (DUAL/SPLIT).

#### ***Touch sensitivity (TOUCH)***

This function allows you to change the touch sensitivity of the keyboard. A harder touch sensitivity allows an experienced player to use the dynamic range of the instrument with finer nuances. If you want to achieve the full volume of the instrument with little effort, choose a softer setting. The touch sensitivity can be completely deactivated with the "Flat" setting. Now every key stroke sounds at the same volume.

#### ***Volume levels (VOLUME R1, VOLUME R2, VOLUME L, VOLUME MUSIC)***

This function allows you to control the volume levels of the different voices (R1, R2, L) or music playback. This function can be useful when combining multiple voices (DUAL/SPLIT) or when playing along with a song from the audio player.

#### ***Metronome time signature (METRONOME)***

This function allows you to select the time signature of the metronome and thus the particular emphasis on the "one."

#### ***Speaker EQ settings (SPEAKER EQ)***

This function allows you to change the sound of the entire speaker system. This allows you to adjust the basic sound of the instrument to your preferences, the style of music, or the room acoustics.

### ***String resonance (STRING RES.)***

This function allows you to adjust the strength of the string resonance simulation. On a natural piano, strings that are not struck by the player can also resonate (resonance effect). These natural resonances are calculated electronically in the string resonance simulation and give your instrument a more overtone-rich, natural sound. Depending on your playing style, the selected touch sensitivity, and the style of music, too much string resonance simulation may be distracting. In this case, select a lower value.

### ***Effects (REVERB TYPE, REVERB LEVEL, CHORUS TYPE, CHORUS LEVEL, MIC FX TYPE, MIC FX LEVEL)***

This function allows you to apply specific effects to the piano sound or the microphone. You can choose from room effects such as reverb, sound effects such as chorus, and microphone effects such as echo. First select the type of effect, then select the volume of the effect in the next menu item.

### ***Audio player playback mode (SONG LOOP)***

This function allows you to select the playback mode of the audio player. Activating the "Song Loop" function plays either a selected song (Single) or all available songs (All) in an endless loop.

### ***Deactivating the internal sound generator (LOCAL)***

The Local function allows you to deactivate the internal sound generator (Local Off) if you want to use the instrument as a control element for a DAW or a MIDI-enabled computer program/app.

**Table - general settings**

| Function                             | Display      | Control range                                      |
|--------------------------------------|--------------|--|
| Transpose                            | TRANSCOPE    | -12 - +12  |
| Transpose the voice by an octave. R1 | OCTAVE R1    | -1 - +1  |
| Transpose voice R1 by an octave      | OCTAVE R2    | -1 - +1  |
| Octave voice L                       | OCTAVE L     | -1 - +1  |
| Touch sensitivity                    | TOUCH        | Hard 2, Hard 1, Normal, Soft 1, Soft 2, Flat       |
| Volume level Voice R1                | VOLUME R1    | 0 - 32   |
| Volume level Voice R2                | VOLUME R2    | 0 - 32   |
| Volume level Voice L                 | VOLUME L     | 0 - 32   |
| Volume level for music player        | VOLUME MUSIC | 0 - 32   |
| Metronome time signature             | METRANOME    | 2/2, 0/4, 2/4, 3/4, 4/4,..9/4, 3/8, 6/8, 9/8, 12/8 |
| Speaker EQ setting                   | SPEAKER EQ   | Piano, Classical, Jazz, Pop, Rock, R&B             |
| String resonance strength            | STRING RES.  | 0 - 32   |

|  |              |   |
|--|--------------|---|
| Spatial sound effect                                     | REVERB TYPE  | Room 1-3, Hall 1-4, Church, My Garage, Piano Hall                             |
| Strength of the room sound effect                        | REVERB LEVEL | 0 - 32  |
| Voice effect   | CHORUS TYPE  | Chorus 1-4, GM Cho. 1-2, Celeste 1-2, Symphonic 1-2, Delay 1-2                |
| Strength of the voice effect                             | CHORUS LEVEL | 0 - 32  |
| Microphone effect  | MIC FX TYPE  | Echo, Pan, Stereo, Doubler, Distortion, Lo-Fi, Enhancer, Pitch Up, Pitch Down |
| Microphone effect strength                               | MIC FX LEVEL | 0 - 32  |
| Playback mode  | SONG LOOP    | Single, All, Off  |
| Deactivation of the internal sound generator (Local Off) | LOCAL        | ON, OFF   |

The respective settings are automatically saved when the instrument is switched off.

## 2. Additional settings

Press and hold the FUNCTION button to access the menu for additional settings.

Press the FUNCTION button repeatedly to scroll through the individual functions.

You can now change the setting for the selected function by turning the rotary knob to the right of the display.

The additional settings include the following functions:

### ***MIDI Out Channels (MIDI OUT CH)***

This function allows you to change the MIDI output channel of Voice R1 if required for your application.

### ***Auto power off (POWER OFF)***

This setting allows you to set the time until the instrument switches off automatically when not in use. To save energy, always select the lowest possible value for the auto-off function. Only deactivate the auto-off function for stage use.

### ***Time and date setting (YEAR, MONTH, DAY, HOUR, MINUTE)***

Here you can set the system time. This is noted, for example, during mp3 music recordings.

### ***Reset (SYSTEM RESET)***

This function allows you to reset the instrument to its factory settings. Caution: The reset cannot be undone. To reset the piano to its factory settings, select "YES" (press the RIGHT button) when "Reset all settings?" appears on the display. Otherwise, exit the menu item by selecting "No" (press the LEFT button). Do not disconnect the device from the power supply during the reset, as this could cause irreparable damage to the piano's operating system.

**Table - Additional settings**

| Function                  | Display      | Control range         |
|---------------------------|--------------|-----------------------|
| MIDI channel settings     | MIDI OUT CH  | 1 - 16                |
| Automatic switch-off      | POWER OFF    | Never, 15 min, 1 hour |
| System time year          | YEAR         | 2015-2100             |
| System time month         | MONTH        | Jan. – Dec.           |
| System time day           | DAY          | 1 - 31                |
| System time hour          | HOUR         | 0 - 23                |
| System time minute        | MINUTE       | 0 - 59                |
| Reset to factory settings | SYSTEM RESET | No, Execute           |

The respective settings are automatically saved when the instrument is switched off.

## Connecting a computer or smart device

Connect the computer or smart device to the USB-to-Host socket on the piano using the appropriate cable. Then turn on the piano.

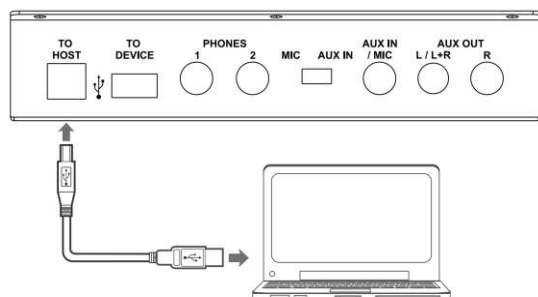

Use the following cables for this purpose:

Connection to PC: USB A to B cable (Windows XP SP3/OSX 10.8 or higher)

Connection to a smart device: USB C to USB B cable (conditional from Android 4.0 – some Android devices do not have the necessary drivers. In this case, no connection is possible; use a PC if possible)

Connection to Apple smart device: Apple Camera Connection Kit (iOS 6.0 or higher)

Both audio and MIDI data can be communicated via the piano's USB-to-Host connection.

If you are using the piano as a MIDI input device, the internal sound generator can be deactivated if necessary using the LOCAL OFF function in the function menu.

## Troubleshooting

If a malfunction occurs, please check the following sources of error.

| Error                                | Cause   | Solution   |
|--------------------------------------|---|--|
| The piano cannot be switched on      | <ol style="list-style-type: none"> <li>1. The power cord is not plugged in</li> <li>2. The power outlet has no power</li> </ol>   | <ol style="list-style-type: none"> <li>1. Plug the power cord in properly</li> <li>2. Use a different power outlet</li> </ol>  |
| No sound is coming from the speakers | <ol style="list-style-type: none"> <li>1. The volume is set to the lowest level</li> <li>2. Headphones (adapter) are plugged into the headphone jack</li> <li>3. The power cord is not plugged in</li> </ol>  | <ol style="list-style-type: none"> <li>1. Increase the volume setting</li> <li>2. Remove the headphones (adapter) from the headphone jack</li> <li>3. Plug the instrument into a power outlet</li> </ol>   |
| The instrument is emitting noise     | <ol style="list-style-type: none"> <li>1. There are devices with interference properties (freezer, washing machine, etc.) in the immediate vicinity</li> <li>2. Objects on or near the instrument are resonating</li> <li>3. Screw connections on the instrument have loosened due to vibrations or dry ambient air</li> <li>4. The noise only occurs when headphones are used</li> </ol> | <ol style="list-style-type: none"> <li>1. Move the piano away from other electrical appliances (especially those with motors)</li> <li>2. Remove any resonating objects from the vicinity of the piano</li> <li>3. Tighten all screws that are accessible from the outside</li> <li>4. Clean the headphone plug or replace the headphones</li> </ol> |

## Product specifications

|                          |   |
|--------------------------|---|
| Keyboard                 | 88 touch-sensitive hammer keys with triple sensor technology      |
| Touch sensitivity        | 6 levels (Hard 2, Hard 1, Normal, Soft 1, Soft 2, Flat)           |
| Max. polyphony           | 256   |
| Voices                   | 40  |
| Demo                     | 40  |
| Pedals                   | 3 (soft, sostenuto, sustain)                                      |
| Connections              | USB to Host, USB to Device, 2x headphones, Aux-In/MIC-In, Aux Out |
| Speaker output           | 2x30W + 2x20W   |
| Dimensions (WxDxH in mm) | 1407x505x1062   |
| Included                 | Power supply 15V, 2500mA, + inside                                |

## **WEEE declaration (Waste of Electrical and Electronic Equipment)**

Your product has been designed and manufactured using high-quality materials and components that are recyclable and reusable. This symbol indicates that electrical and electronic equipment must be disposed of separately from household waste at the end of its service life.

Please dispose of this device at your local municipal collection point or recycling center.

Please help protect the environment in which we all live.

All technical data and appearances are subject to change without prior notice. All information was correct at the time of printing. Musikhaus Kirstein GmbH accepts no liability for the accuracy or completeness of the descriptions, photos, or statements contained in this manual. Printed colors and specifications may vary slightly from the product. Products from Musikhaus Kirstein GmbH are only sold through authorized dealers. Distributors and dealers are not representatives of Musikhaus Kirstein GmbH and are not authorized to legally bind Musikhaus Kirstein GmbH in any way, either expressly or by conclusive action.

 **KIRSTEIN.de**

**Musikhaus Kirstein GmbH**

**Bernbeurener Str. 11**

**86956 Schongau – Germany**

**Phone: 0049-8861-909494-0**

**Email: [info@kirstein.de](mailto:info@kirstein.de)**



## Appendix

### Voice list

| No. | Voice Name       | No. | Voice Name         |
|-----|------------------|-----|--------------------|
| 1   | Grand Piano      | 21  | Cello              |
| 2   | Grand Piano/Wide | 22  | Orchestral Harp    |
| 3   | Bright Piano     | 23  | String Ensembles 1 |
| 4   | Electric Grand   | 24  | String Ensembles 2 |
| 5   | Honky Tonk       | 25  | Choir Aahs         |
| 6   | Harpsichord      | 26  | Trumpet            |
| 7   | E.Piano 1        | 27  | Trombone           |
| 8   | E.Piano 2        | 28  | Tuba               |
| 9   | Clavi            | 29  | French Horn        |
| 10  | Drawbar Organ    | 30  | Soprano Sax        |
| 11  | Percussive Organ | 31  | Alto Sax           |
| 12  | Rock Organ       | 32  | Tenor Sax          |
| 13  | Church Organ     | 33  | Baritone Sax       |
| 14  | Reed Organ       | 34  | Flute              |
| 15  | Accordion        | 35  | Pan Flute          |
| 16  | Tango Accordion  | 36  | Sitar              |
| 17  | Guitar & Bass 1  | 37  | Banjo              |
| 18  | Guitar & Bass 2  | 38  | Shamisen           |
| 19  | Bass & Vibra     | 39  | Koto               |
| 20  | Violin           | 40  | Bag Pipe           |

### Song list

| No. | Song-Name                | No. | Song-Name         |
|-----|--------------------------|-----|-------------------|
| 1   | The Entertainer          | 46  | Four Little Swans |
| 2   | Rialto Ripples (Rag)     | 47  | Progress          |
| 3   | Neapolitan Song          | 48  | Eclogue           |
| 4   | Waltzes                  | 49  | The Limpid Stream |
| 5   | Turkish March            | 50  | Brave Cavalier    |
| 6   | Schos Doll's Dance No. 2 | 51  | The Chatterbox    |
| 7   | Minuet In D Major        | 52  | Tarantella        |
| 8   | Inquietude               | 53  | Frankness         |
| 9   | Italian Polka            | 54  | Tender Grieving   |
| 10  | Moment Musical           | 55  | The Farewell      |
| 11  | Prelude In C-Sharp Major | 56  | The Chase         |
| 12  | The Happy Farmer         | 57  | Habanera          |

|    |  |    |                                 |
|----|--|----|---------------------------------|
| 13 | The Rag-Time Dance                       | 58 | Prelude In C Major              |
| 14 | Piano Sonata In C Major, K.330. III      | 59 | Piano Sonata In C Major, K.545. |
| 15 | Mazurka                                  | 60 | Piano Sonate op.49-2            |
| 16 | Prelude In E Major                       | 61 | Serenade                        |
| 17 | Piano Sonata In A Major, K.331. I        | 62 | Prelude D-Dur/D major BWV936    |
| 18 | Waltz For Piano In G-Sharp Minor         | 63 | Prelude C-Dur/C major BWV924    |
| 19 | Gavotte                                  | 64 | Toys Ragtime                    |
| 20 | L' Arabesque                             | 65 | Maple leaves Ragtime            |
| 21 | Austria Variation                        | 66 | Chicken pecking Ragtime         |
| 22 | Schos Doll's Dance No. 7                 | 67 | Pretty girl Ragtime             |
| 23 | To A Wild Rose                           | 68 | Menuett G dur 3                 |
| 24 | Gavotte I                                | 69 | Perpetuum mobile                |
| 25 | Waltz                                    | 70 | The Nightingale was singing     |
| 26 | Minuet In G Major (BWV Anh. 116)         | 71 | Gipsy Rondo                     |
| 27 | Innocence                                | 72 | Fountain                        |
| 28 | Tchaikovsky Waltz                        | 73 | Fur Elise                       |
| 29 | Salut d' Amour                           | 74 | Prelude F-Dur/F major BWV927    |
| 30 | Barcarolle                               | 75 | Prelude d-Moll/D minor BWV935   |
| 31 | Robot Doll                               | 76 | Prelude e-Moll/E minor BWV938   |
| 32 | Consolation                              | 77 | Prelude G-Dur/G major BWV936    |
| 33 | 2-Part Invention #13 In A Minor.B.W. Iii | 78 | Dove                            |
| 34 | Minuet In G Major (BWV Anh. 114)         | 79 | Knight                          |
| 35 | Barcarolle                               | 80 | Ave Maria                       |
| 36 | Norwegian Dance No.2                     | 81 | Prelude G-Dur/G major BWV902a   |
| 37 | Moseta Dance                             | 82 | Menuett G dur 4                 |
| 38 | The Small Gathering                      | 83 | The two part inventions 1       |
| 39 | The Return                               | 84 | The two part inventions 2       |
| 40 | The Wagtail                              | 85 | Gavotte                         |
| 41 | Bulie Dance                              | 86 | The angels singing              |
| 42 | Tender Blossom                           | 87 | Minuet                          |
| 43 | Grace                                    | 88 | Lyrical Rondo                   |
| 44 | Cherish The Memories                     | 89 | Swallow                         |
| 45 | Chopsticks                               | 90 | Minute Waltz                    |

The contents of the voice list and song list are not guaranteed. Musikhaus Kirstein GmbH reserves the right to change individual sounds and pieces of music without giving reasons or to delete them without replacement.