

EON700

SERIES

User's Guide

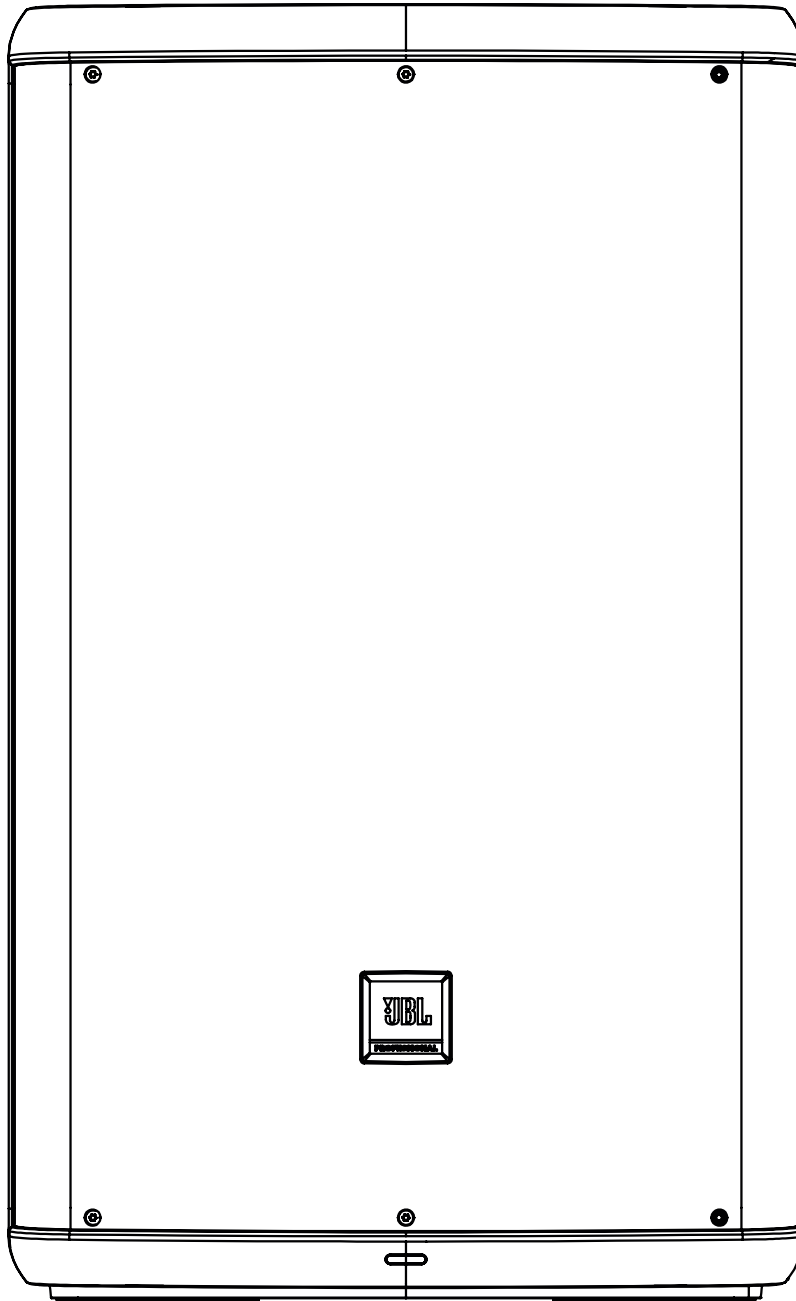

CONTENTS

Safety Instructions	4
Precautions.....	6
Declaration of Conformity.....	7
Intro to EON700	8
Block Diagram	10
Application Examples	11
Mixer Panel.....	13
Mixer Panel Functions	14
EasyNav LCD	16
App.....	20
EON710 Specifications	21
EON712 Specifications	22
EON715 Specifications	23
EON718S Specifications	24
Cables & Connectors.....	25
Contact Information	26
Warranty information	27

SAFETY INSTRUCTIONS



The EON700 system covered by this manual is not intended for use in high moisture environments. Moisture can damage the speaker cone and surround and cause corrosion of electrical contacts and metal parts. Avoid exposing the speakers to direct moisture. Keep speakers out of extended or intense direct sunlight. The driver suspension will prematurely dry out and finished surfaces may be degraded by long-term exposure to intense ultra-violet (UV) light. The EON700 system can generate considerable energy. When placed on a slippery surface such as polished wood or linoleum, the speaker may move due to its acoustical energy output. Precautions should be taken to assure that the speaker does not fall off a stage or table on which it is placed.

HEARING DAMAGE, PROLONGED EXPOSURE TO EXCESSIVE SPL

The EON700 system is capable of generating sound pressure levels (SPL) sufficient to cause permanent hearing damage to performers, production crew, and audience members. Caution should be taken to avoid prolonged exposure to SPL in excess of 85 dB.

CARE & CLEANING

EON700 systems may be cleaned with a dry cloth. Do not allow moisture into any of the openings in the system. Ensure that the system is unplugged from the AC outlet before cleaning.

THIS APPARATUS CONTAINS POTENTIALLY LETHAL VOLTAGES. TO PREVENT ELECTRIC SHOCK OR HAZARD, DO NOT REMOVE CHASSIS, MIXER MODULE, OR AC INPUT COVERS. NO USER SERVICEABLE PARTS INSIDE. REFER SERVICING TO QUALIFIED SERVICE PERSONNEL.

WEEE Notice



The Directive 2012/19/EU on Waste Electrical and Electronic Equipment (WEEE), which entered into force as European law on 14/02/2014, resulted in a major change in the treatment of electrical equipment at end-of-life.

The purpose of this Directive is, as a first priority, the prevention of WEEE, and in addition, to promote the reuse, recycling and other forms of recovery of such wastes so as to reduce disposal. The WEEE logo on the product or on its box indicating collection for electrical and electronic equipment consists of the crossed-out wheeled bin, as shown below.

This product must not be disposed of or dumped with your other household waste. You are liable to dispose of all your electronic or electrical waste equipment by relocating over to the specified collection point for recycling of such hazardous waste. Isolated collection and proper recovery of your electronic and electrical waste equipment at the time of disposal will allow us to help conserving natural resources. Moreover, proper recycling of the electronic and electrical waste equipment will ensure safety of human health and environment. For more information about electronica and electrical waste equipment disposal, recovery, and collection points, please contact your local city center, household waste disposal service, shop from where you purchased the equipment, or manufacturer of the equipment.

RoHS Compliance

This product is in compliance with Directive 2011/65/EU and (EU) 2015/863 of the European Parliament and of the Council of 19. 31/03/2015 on the restriction of the use of certain hazardous substances in electrical and electronic equipment.

REACH

REACH (Regulation No 1907/2006) addresses the production and use of chemical substances and their potential impacts on human health and the environment. Article 33 (1) of REACH Regulation requires suppliers to inform the recipients if an article contains more than 0.1% (per weight per article) of any substance(s) on the Substances of Very High Concern (SVHC) Candidate List ('REACH candidate list').

This product contains the substance "lead" (CAS-No. 7439-92-1) in a concentration of more than 0.1% per weight.

At the time of release of this product, except for the lead substance, no other substances of REACH candidate list are contained in a concentration of more than 0.1% per weight in this product.

Note: on June 27, 2018, lead was added to the REACH candidate list. The inclusion of lead in the REACH candidate list does not mean that lead-containing materials pose an immediate risk or results in a restriction of permissibility of its use.

-
1. READ these instructions.
 2. KEEP these instructions.
 3. HEED all warnings.
 4. FOLLOW all instructions.
 5. DO NOT use this apparatus near water.
 6. CLEAN ONLY with dry cloth.
 7. DO NOT block any ventilation openings. Install in accordance with the manufacturer's instructions.
 8. DO NOT install near any heat sources such as radiators, heat registers, stoves, or other apparatus (including amplifiers) that produce heat.
 9. DO NOT defeat the safety purpose of the polarized or grounding type plug. A polarized plug has two blades with one wider than the other. A grounding type plug has two blades and a third grounding prong. The wider blade or the third prong are provided for your safety. If the provided plug does not fit into your outlet, consult an electrician for replacement of the obsolete outlet.
 10. PROTECT the power cord from being walked on or pinched, particularly at plugs, convenience receptacles, and the point where they exit from the apparatus.
 11. ONLY USE attachments/accessories specified by the manufacturer.
 12.  USE ONLY with a cart, stand, tripod, bracket, or table specified by the manufacture, or sold with the apparatus. When a cart is used, use caution when moving the cart/apparatus combination to avoid injury from tip-over.
 13. UNPLUG this apparatus during lightning storms or when unused for long periods of time.
 14. REFER all servicing to a qualified service personnel. Servicing is required when the apparatus has been damaged in any way, such as power-supply cord or plug is damaged, liquid has been spilled or objects have fallen into the apparatus, the apparatus has been exposed to rain or moisture, does not operate normally, or has been dropped.
 15. DO NOT expose this apparatus to dripping or splashing and ensure that no objects filled with liquids, such as vases, are placed on the apparatus.
 16. To completely disconnect this apparatus from the AC Mains, disconnect the power supply cord plug from the AC receptacle.
 17. Where the mains plug or an appliance coupler is used as the disconnect device, the disconnect device shall remain readily operable.
 18. DO NOT overload wall outlets or extension cords beyond their rated capacity as this can cause electric shock or fire.
 19. For adequate ventilation, do not install this equipment in a confined or enclosed space, such as a book case or similar unit. Product ventilation should not be impeded by covering the ventilation openings with items such as newspaper, tablecloths, curtains, etc.



The exclamation point, within an equilateral triangle, is intended to alert the user to the presence of important operating and maintenance (servicing) instructions in the literature accompanying the product.



The lightning flash with an arrowhead symbol within an equilateral triangle is intended to alert the user to the presence of uninsulated "dangerous voltage" within the product's enclosure that may be sufficient in magnitude to constitute a risk of electrical shock to persons.

WARNING: To reduce the risk of fire or electrical shock, do not expose this apparatus to rain or moisture.

WARNING: No naked flame sources – such as lighted candles –should be placed on the product.

WARNING: Equipment shall be connected to a MAINS socket outlet with a protective earthing connection.

PRECAUTIONS

WARNING: This product is intended to be operated ONLY from the voltages listed on the back panel. Operation from other voltages other than those indicated may cause irreversible damage to the product and void the product's warranty. The use of AC Plug Adapters is cautioned because it can allow the product to be plugged into voltages in which the product was not designed to operate. If you are unsure of the correct operational voltage, please contact your local distributor and/or retailer. If the product is equipped with a detachable power cord, use only the type provided, or specified, by the manufacturer or your local distributor.

OPERATING TEMPERATURE RANGE: -20°C - 40°C (-4°F - 104°F)



WARNING: Do Not Open! Risk of Electrical Shock. Voltages in this equipment are hazardous to life. No user-serviceable parts inside. Refer all servicing to qualified service personnel.

Place the equipment near a main power supply outlet and make sure that you can easily access the power breaker switch.

DO NOT UNDER ANY CIRCUMSTANCES OPERATE THE UNIT WITH THE WRONG VOLTAGE SELECTED. DOING SO MAY RESULT IN SERIOUS DAMAGE TO YOUR PA SYSTEM WHICH WILL NOT BE COVERED BY WARRANTY.

FCC AND CANADA EMC COMPLIANCE INFORMATION: This device complies with Part 15 of the FCC Rules. Operation is subject to the following two conditions

1. This device may not cause harmful interference, and (2) this device must accept any interference received, including interference that may cause undesired operation.

CAUTION: Changes or modifications not expressly approved by the manufacturer could void the user's authority to operate this device.

NOTE: This equipment has been tested and found to comply with the limits for a Class B digital device, pursuant to Part 15 of the FCC Rules. These limits are designed to provide reasonable protection against harmful interference in a residential installation. This equipment generates uses and can radiate radio frequency energy and, if not installed and used in accordance with the instructions, may cause harmful interference to radio communications. However, there is no guarantee that interference will not occur in a particular installation. If this equipment does cause harmful interference to radio or television reception, which can be determined by turning the equipment off and on, the user is encouraged to try to correct the interference by one or more of the following measures: Reorient or relocate the receiving antenna. Increase the separation between the equipment and receiver. Connect the equipment into an outlet on a circuit different from that to which the receiver is connected. Consult the dealer or an experienced radio/TV technician for help.

CAUTION: This product is for non-residential use only.

WARNING: This equipment is compliant with Class B of CISPR 32. In a residential environment this equipment may cause radio interference.

CAN ICES-003(B)/NMB-003(B)



Protective earthing terminal. The apparatus should be connected to a mains socket outlet with a protective earthing connection.

DECLARATION OF CONFORMITY

WIRELESS TRANSMITTER COMPLIANCE INFORMATION: The term "IC:" before the radio certification number only signifies that Industry Canada technical specifications were met.

Le terme «IC:» avant le numero de certification radio signifie seulement que les specifications techniques d'Industrie Canada ont ete respectees.

This device contains licence-exempt transmitter(s)/receiver(s) that comply with Innovation, Science and Economic Development Canada's licence-exempt RSS(s). Operation is subject to the following two conditions (1) this device may not cause harmful interference, and (2) this device must accept any interference, including interference that may cause undesired operation of the device.

Cet appareil contient des émetteurs / récepteurs exemptés de licence conformes aux RSS (RSS) d'Innovation, Sciences et Développement économique Canada. L'exploitation est autorisée aux deux conditions suivantes : (1) l'appareil ne doit pas produire de brouillage, et (2) l'utilisateur de l'appareil doit accepter tout brouillage radioélectrique subi, même si le brouillage est susceptible d'en compromettre le fonctionnement.

This equipment complies with FCC and IC radiation exposure limits set forth for an uncontrolled environment. This equipment should be installed and operated with minimum distance 20cm between the radiator and your body. This transmitter must not be co-located or operating in conjunction with any other antenna or transmitter.

Cet appareil est conforme a FCC et IC !'exposition aux rayonnements limites fixees pour un environnement non controle. Cet appareil doit etre installe et utilise avec une distance minimale de 20cm entre le radiateur et votre corps. Cet transmetteur ne doit pas etre cositue ou operant en liaison avec toute autre antenne ou transmetteur.

EU COMPLIANCE INFORMATION:

Hereby, HARMAN Professional, Inc., declares that the equipment type EON700 is in compliance to the following: European Union Restriction of Hazardous Substances Recast (RoHS2) Directive 2011/65/EU; European Union WEEE (recast) Directive 2012/19/EU; European Union Registration, Evaluation, Authorization and Restriction of Chemicals (REACH) Directive 1907/2006; European Radio Equipment Directive (RED) 2014/53/EU

You may obtain a free copy of the full Declaration of Conformity by visiting:
<http://www.jblpro.com/www/product-support/downloads>

WIRELESS FREQUENCY RANGE AND WIRELESS OUTPUT POWER:
2402MHz - 2480MHz
6.00mW

ENVIRONMENTAL:



此标识适用于在中华人民共和国销售的电子信息产品。标识中间的数字为环保实用期限的年数。

Este equipamento não tem direito à proteção contra interferência prejudicial e não pode causar interferência em sistemas devidamente autorizados

INTRO TO EON700

GETTING STARTED

Congratulations on your purchase of JBL Professional EON700 loudspeakers! We know you are anxious to get up and running as fast as possible, which is why you are reading this section. The following will help you get set up as soon as possible.

Packaging Contents

Your EON700 should include:

- 1 EON700 Full Range or Subwoofer Cabinet
- 1 6' (2m) AC Power Cable
- 1 QSG

Unboxing

1. Open packaging
2. Open plastic to expose cabinet handle on top (full range) or sides (subwoofer)
3. Remove cabinet from box/plastic
4. Plug AC cable into inlet
5. Power up

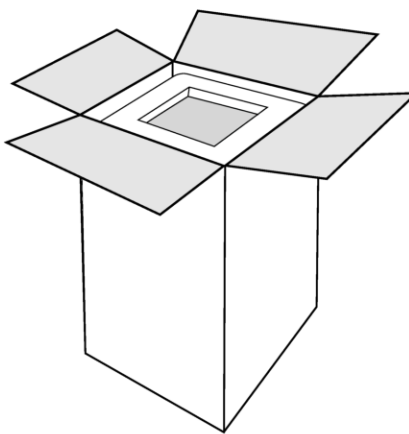

1

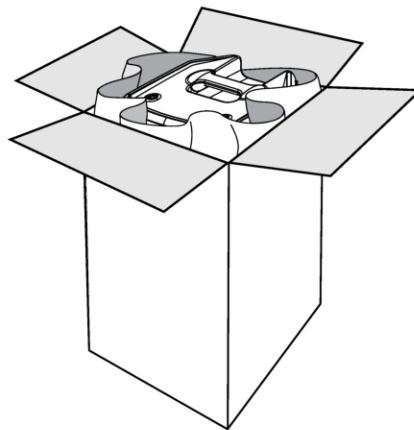

2

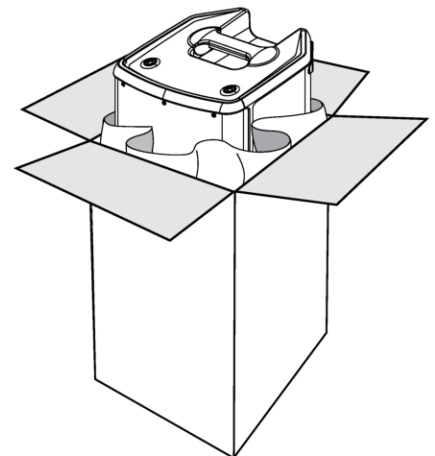

3

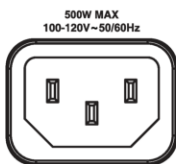

4

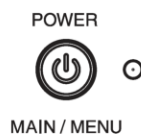

5

SETTING UP

How to set up

1. Insert input into desired channel
2. Slowly turn the Main knob to increase your main volume.
3. Adjust the Channel Gain knobs until your desired volume is achieved.

How to turn on/off

Press the Power Button for .5 of a second to engage power.

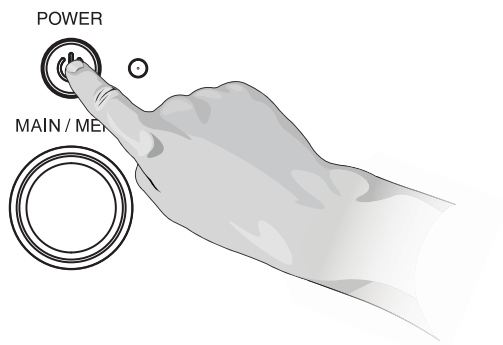

P.A. BASICS

A mixing board is actually a very simple device that takes the audio input signals (from the input channels) and “mixes” them to the outputs. The mixing board controls will typically enable the user to blend the input channel signal levels, affect their tone, and adjust each channel’s reverb level. The signal is then fed from the mixing board to the amplifiers and onto the speakers. The EON700 is a self-contained PA system, which includes a mixing board, amplifiers, and speakers.

GETTING ACQUAINTED WITH EON700

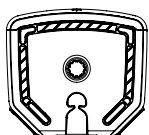

Bottom View

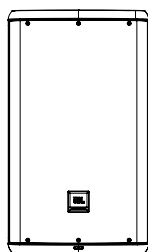

Front View

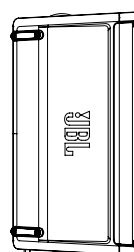

Left View

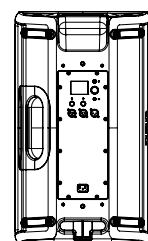

Rear View

APPLICATION EXAMPLES

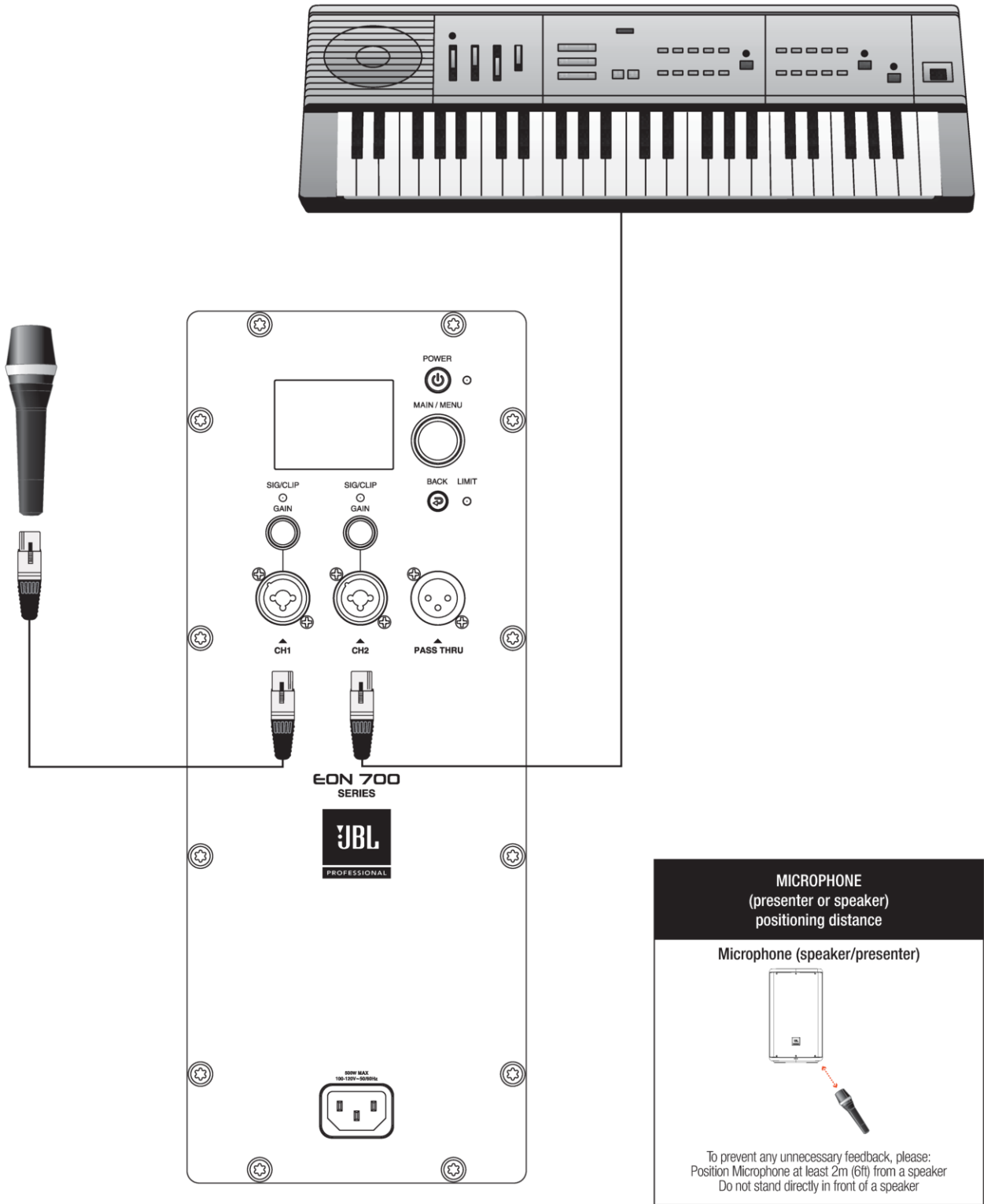

INSTRUMENTS & MIC PLUGGED INTO MIXER

CH1 XLR-1/4" Combo Mic, CH2 XLR-1/4" Combo Mic Keyboard

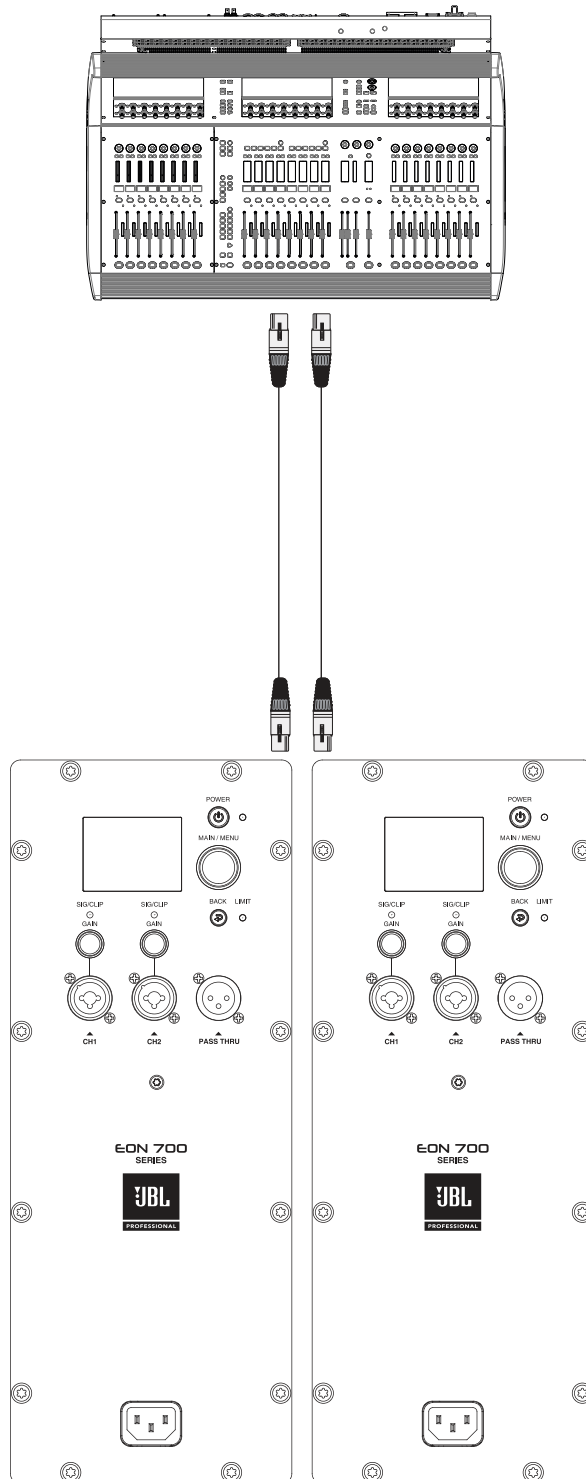

USING TWO SYSTEMS AS MAINS
 EON700 Left and EON700 Right

MIXER PANEL

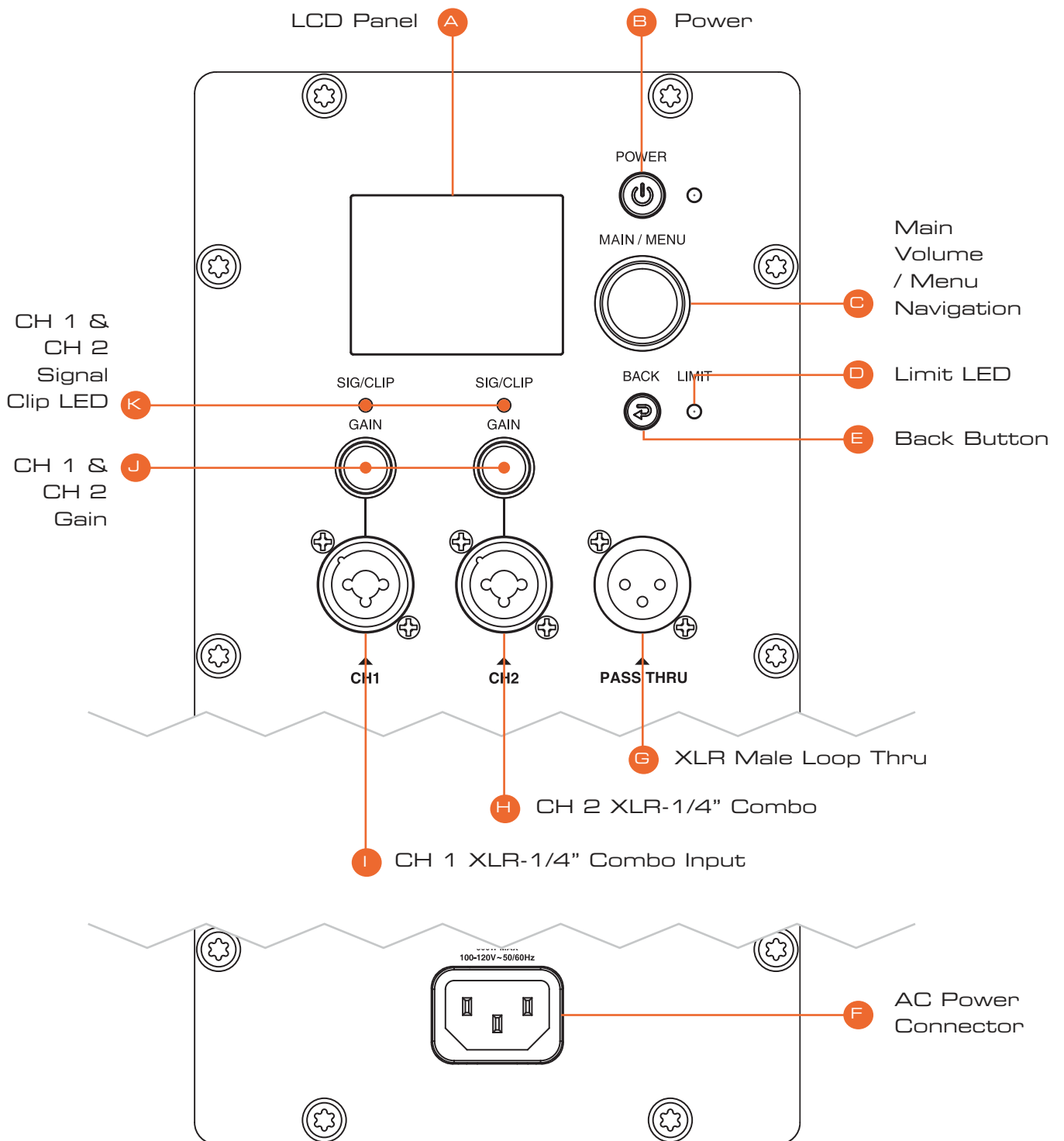

MIXER PANEL FUNCTIONS

A. LCD Panel

The LCD is used to display basic diagnostic information and allow access to more advanced features through a menu system. See the LCD GUI specification for more details on the LCD menu system, features, and navigation. The LCD will refresh at approximately 4Hz and is not suitable for meters or any other fast motion items.

B. Power Button

The Power Button is a momentary push button. It is used to toggle the unit between the On and Off states. When in the Off state, a short press and release of the Power Button will put the unit into the On state.

C. Main Volume / Menu Navigation

Controls LCD Display

- Rotary encoder: In Menu - Clockwise down menu/Anti-clockwise up menu
 - Press to select menu item
 - + On Home screen, Main Volume increase by rotating the knob clockwise.
- + On Home screen, Main Volume decrease by rotating the knob counterclockwise.

D. Limit LED

Amplifier is reaching clip.

E. Back Button

Press to return to previous menu item

F. Power Inlet

Inlet adapter for A/C power cable

G. XLR Male Loop Thru

This XLR output connector provides a method of sending audio out to an external source. If signal is present on all inputs, the inputs will be summed and sent out as a mix: Can be adjusted in the pass through menu section..

H. CH2 XLR-1/4" Combo Input

XLR – 1/4" combination connector (1 for each input) are used for the analog audio inputs.

Knobs and Functions

The EON700 comes equipped with push button rotaries to make for easy navigation and hardware usage.

- A single press of the MAIN/MENU knob will open up the main menu.
- Pressing and holding the MAIN/MENU knob for 2s will mute the SPEAKER.
- Pressing and holding a CHANNEL KNOB for 2s will mute the CHANNEL.

Buttons and Functions

- The POWER button turns on/off the speaker. Hold for .5s to turn on the speaker and .5s to turn off the speaker.
- The BACK button will back you out of the current screen you are in without saving changes. This can be thought of as a “CANCEL” button.

LEDs and Functions

1. Signal detection - LED below channel knobs will periodically flash yellow to indicate signal is present.
2. LED function when Muting Channels/Speaker : LED Below Channel knobs will slowly flash RED when a channel is muted.

SSM

	Levels	LED Status
Default: no signal		LEDs off
Muted Channel	Muted Channel	Muted Channels LED flashes dim Red/Green
Channel Signal Level	Very Low/No Signal	Channel LED off
	Normal Signal	Channel LED Bright Green
	Strong Signal	Channel LED Bright Yellow
	Clipping	Channel LED Bright Red

EASYNV LCD

Intro to the EasyNav LCD

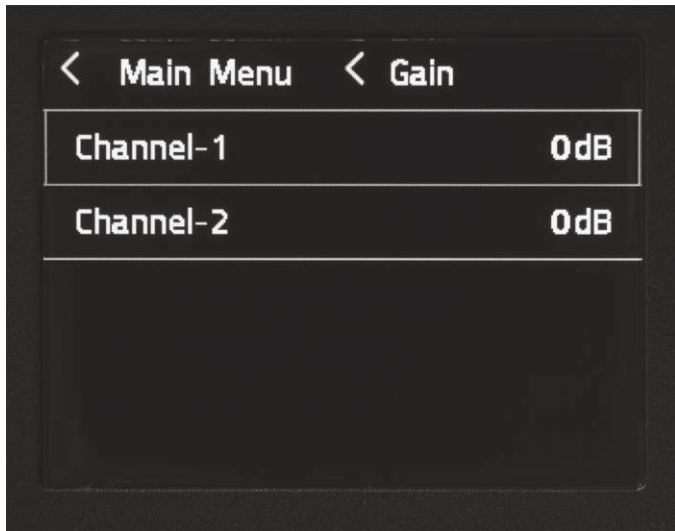

Main Menu

- Pressing the **Main/Menu** rotary at any time will take you to the EON700's main menu. Here, users can access the main menu functions of the EON700.
- **Gain** adds preamp gain to the system to support microphone usage. EON700's fader runs standard in LINE LEVEL, but accessing the GAIN menu can allow users to plug a microphone in directly.
 - Press MAIN/MENU to access the GAIN menu.
 - Select which channel you want to add GAIN to by rotating and pressing the MAIN/MENU knob.
 - Turn your gain up to desired levels.
- **Ducking by Soundcraft®** is a type of side-chain compressor most often used to lower the level of music playback while a person is talking into a microphone. This feature allows the user to choose which mic channels the use as sensors, the sensitivity of each channel, and if they want a little or a lot of music reduction while a person is speaking. This menu engages the ducking feature, allows users to select which channel(s) will act as the trigger for ducking, and set individual thresholds of each channel.
 - To access this menu, navigate to ducking and press the Main/Menu button.
 - To turn on ducking, navigate to Ducking and press the Main/Menu button
 - Turn the knob CLOCKWISE to activate ducking
 - Turn the knob COUNTER-CLOCKWISE to disable ducking
 - **“Channel Sensors”** give the user the option to select which mic inputs can be used to trigger the Bluetooth playback music ducking. The user can select any combination of the mic inputs to turn on as sensors for Bluetooth music ducking.
 - To adjust the Channel Sensor, navigate to the Channel Sensor field and press the MAIN/MENU button
 - Navigate to the respective channel(s) you wish to set as a sensor and press the MAIN/MENU button

-
- Turn the knob CLOCKWISE to activate that channel as a SENSOR for ducking. When this is selected, the respective channel will detect signal and activate the ducking feature on the Bluetooth signal.
 - Turn the knob COUNTER-CLOCKWISE to disable that channel as a SENSOR for ducking. When this is disabled, signal detection on this channel will NOT trigger the ducking feature on the Bluetooth signal.
 - **“Sensitivity Parameters”** give the user the option to select at what volume level each mic input channel will trigger the ducker threshold. Stronger voices may want a higher sensor level. Weaker voices may want a lower sensor level to trigger the music reduction. A lower value represents a less sensitive signal detection
 - Select and edit these values by pressing the MAIN/MENU knob while Sensitivity Parameters is highlighted.
 - Navigate to the respective channel you wish to edit and press the MAIN/MENU knob to select.
 - Adjust the parameter.
 - Press the MAIN/MENU knob to save the adjustment
 - Press the BACK button to cancel this adjustment.
 - **Range** is a parameter that tells the Bluetooth signal how much volume should be reduced when signal detection meets the desired level.
 - To adjust this, navigate to RANGE and press the MAIN/MENU knob.
 - Adjust the parameter
 - Press the MAIN/MENU knob to save the adjustment
 - Press the BACK button to cancel this adjustment.
 - **Release Time** is a parameter that tells Bluetooth signal when it should return to normal volume after signal is no longer detected. This value is represented in ms (milliseconds).
 - To adjust this, navigate to RELEASE RETURN TIME field and press the MAIN/MENU knob.
 - Adjust the parameter
 - Press the MAIN/MENU knob to save the adjustment
 - Press the BACK button to cancel this adjustment.
 - **dbx DriveRack Output** - DriveRack is a line of hardware products produced by Harman’s dbx brand. These rack mount signal processors provide detailed control for final processing and crossovers before feeding the mix to one or more speakers. This DriveRack functionality embedded into EON700 is designed to optimize the combination of speaker and Pass Thru outputs built into this JBL speaker.
 - **AFS by dbx**, or automatic feedback suppression, is a combination of processing that can enable the user to add up to 3 dB more total gain to their output before getting audio feedback back in through the mix inputs. AFS does this using a combination of auto sensing and very tight width parametric EQs before the output master EQ.
 - Stage setup best practices are always recommended for best results to avoid feedback, in combination with the AFS processing system. Microphones have less chance of contributing feedback if they follow

the following position standards on stage:

- Microphones should be behind the front plane of the speakers.
- Microphones should be least two meters to the left or right of the speakers.
- “AFS by dbx” On/Off selection toggles the AFS processor on or off.
- “Reset Filters” will reset all filters, prompting the filters to reset and start over in their discovery of potential feedback frequency risks.
- The **Output EQ** is a package of filter adjustments on the main mix before the audio feeds to the amp and speaker. It includes a collection of easy to select preset curves for common speech and music styles. Each preset can also be loaded into the Custom preset for detailed user adjustable of output parametric EQ’s. The user has adjustments for individual band level, frequency, and width (“Q”).
 - “Output EQ” On/Off enables or bypasses the current settings in the output EQ processor.
 - “Presets” enables rotation of the Main/Menu knob to view and select from the Output EQ presets.
 - Scroll the menu to “Presets” and press the MAIN/MENU knob.
 - Rotate the MAIN/MENU knob to view the available presets.
 - Click the MAIN/MENU knob to load the currently listed preset.
 - Users can load the Custom preset, then double click the MAIN/MENU knob to open the Master EQ editing page. Inside this graph display page you may rotate the MAIN/MENU knob to a specific parametric EQ number and click the MAIN/MENU knob again to select to edit the gain (plus or minus in dB), filter frequency, or “Q” (i.e. adjust the filter width.)
 - Users can load any preset as a starting point, then scroll down and adjust any setting to load the current curve as the Custom preset for further editing. A confirmation dialog will appear, warning the user that doing this will remove the current Custom preset settings and load it with the currently viewed settings.
- **Bass Boost** – The Bass Boost functionality adds 2db of bass to the system.
 - Bass Boost On/Off enables or disables bass boost functionality.
- **Pass Thru XLR** output can be set to assist in feeding the mix to additional speakers. This section includes presets and settings based on the type of speaker the Pass Thru will be feeding and how it is positioned in comparison to this speaker and the audience.
 - “Pass Thru” On/Off” enables or disables the Pass Thru XLR output feed.
 - “Presets” enables selection of three types of speakers combinations using the Pass Thru XLR output:
 - “Full Range” is designed for feeding another full range speaker. This feeds both this and the Pass Thru XLR out to another speaker the same full frequency range mix.
 - “Sub” preset automatically configures the below settings for isolating low frequencies and only feeding them to Pass Thru XLR out for a subwoofer speaker. Selecting “Sub” automatically sets the internal amp/speaker feed to HPF (“high pass filter”) only signal at above 80Hz and the Pass Thru XLR output to only pass the mix signal below 80Hz.
 - “Custom” allows the user to set the lower settings manually.

-
- “HPF on this Speaker” can be used to remove signal below a selected frequency to the built-in amp/speaker and tweeter bar.
 - “LFP on Pass Thru Out” can be used to set the low pass filter on the Thru Out XLR output feed.
 - **Time Align**
 - Signal delays are used when multiple speakers are in use but speakers are at different distances from the audience.
 - Examples:
 - A subwoofer is front of the stage, while this full range speaker in on the stage. In this configuration, the Pass Thru XLR to subwoofer will need to be slightly delayed to make up for its closer position to the audience.
 - The Pass Thru XLR out is feeding an additional full range speaker placed half way back in the audience, to give additional listening distance. In this case, delay the back fill speaker in the audience to compensate correct time alignment.
 - Time Alignment Basics:
 - To compensate for different distances’, determine the speaker farthest from the audience and delay other speakers with the same signal to “time align” with the speaker farthest away from the audience.
 - Sound travels through air at average humidity and room temperature at about 1.1 feet per ms. Measure the difference in distance of each speaker feeding the audience. Feed the speaker farthest from the audience with no time alignment delay. Set delays for the other closer speakers based on their distance ahead of the farthest back speaker. Measure the distance difference and enter 1 ms per 1.1 feet that each speaker is ahead of the farthest back speaker in your configuration. Time alignment is not perfect as not all audience positions measure the same speaker distance differences.
 - “Delay Pass Thru Out” Enter in ms.
 - “Delay This Speaker” Enter in ms.

Settings

- “BT Audio Pairing” enables Bluetooth audio pairing for up to 30 seconds. This setting turns off when a pairing has been made, or after 30 seconds.
- “BT Control Pairing” enables Bluetooth control pairing for up to 30 seconds with the JBL Pro Control app. This turns off when a pairing has been made, or after 30 seconds.
- The EON700 loudspeaker will confirm a secure pin with the app. Please ensure you confirm this to secure BLE control pairing.
- “LCD Contrast” allows the user to adjust the LCD contrast between 0 and 100%.
- “Firmware Version” shows the current firmware version loaded onto the speaker.
- “Factory Reset” resets all settings in the speaker to factory default, including Bluetooth communication pairing.

APP

JBL Pro Connect

The JBL Pro Connect app is a Bluetooth Low Energy control application used to remotely control the features within the EON700. The app is a free download on iOS and Android.

It is recommended that all users download the app and ensure their unit is operating on the latest firmware for the best experience.



EON710 SPECIFICATIONS

TECHNICAL SPECIFICATIONS

System Type	10IN Powered Loudspeaker
Woofers Model	710G
Woofers Size	10"
Woofers Magnet	Ferrite
Woofers Voice Coil	2"
Tweeter Model	2414H Compression Driver
Tweeter Size	1"
Tweeter Magnet	Neodymium
Transducer Impedance	LF 4ohm rated, HF 8ohm rated
Max SPL	125dB @1m/4Pi
Freq Range -10	52Hz - 20kHz
Freq Range -3	65Hz - 20kHz
Hor Dispersion	110°
Vert Dispersion	60°
Power Rating	1300W peak / 650 RMS
AC Power Input	100V-120V or 220V-240V
Cooling	Passive
LED Indicators	1 Power LED, 1 Limit LED, 1 Front LED, 2 Signal/SSM LEDs
Input Impedance	50k/100k un-balanced/balanced
Input Gain	-∞ to +36db
Crossover Freq	2 kHz
I/O	2 XLR Combo Jacks / BT 1 XLR M Thru
Cabinet	PP+10% Talc
Grille	16GA perforated steel with acoustically transparent black cloth backing
Suspension/Mount	4 M10 Suspension points, 36mm Pole Socket, universal yoke bracket holes
Handles	1, Cable channel on bottom
Net Weight	12Kg
Gross Weight	15.2Kg
Product Dims	587x332x305mm 23.1x13x12in(HxWxL)
Shipping Dims	606x439x407mm 23.85x17.28x16.1in (HxWxL)

EON712 SPECIFICATIONS

TECHNICAL SPECIFICATIONS

System Type	12IN Powered Loudspeaker
Woofers Model	712G
Woofers Size	12"
Woofers Magnet	Ferrite
Woofers Voice Coil	2"
Tweeter Model	2414H Compression Driver
Tweeter Size	1"
Tweeter Magnet	Neodymium
Transducer Impedance	LF 4ohm rated, HF 8ohm rated
Max SPL	127dB @1m/4Pi
Freq Range -10	50Hz - 20kHz
Freq Range -3	60Hz - 20kHz
Hor Dispersion	100°
Vert Dispersion	60°
Power Rating	1300W peak / 650 RMS
AC Power Input	100V-120V or 220V-240V
Cooling	Passive
LED Indicators	1 Power LED, 1 Limit LED, 1 Front LED, 2 Signal/SSM LEDs
Input Impedance	50k/100k un-balanced/balanced
Input Gain	-∞ to +36db
Crossover Freq	2 kHz
I/O	2 XLR Combo Jacks / BT 1 XLR M Thru
Cabinet	PP+10% Talc
Grille	16GA perforated steel with acoustically transparent black cloth backing
Suspension/Mount	4 M10 Suspension points, 36mm Pole Socket, universal yoke bracket holes
Handles	2, cable channel on bottom
Net Weight	14.6kg
Gross Weight	18.4kg
Product Dims	670x381x328mm 26.4x15x12.9in (HxWxL)
Shipping Dims	684x490x430mm 26.92x19.29x16.92in (HxWxL)

EON715 SPECIFICATIONS

TECHNICAL SPECIFICATIONS

System Type	15IN Powered Loudspeaker
Woofers Model	715G
Woofers Size	15"
Woofers Magnet	Ferrite
Woofers Voice Coil	2"
Tweeter Model	2414H Compression Driver
Tweeter Size	1"
Tweeter Magnet	Neodymium
Transducer Impedance	LF 4ohm rated, HF 8ohm rated
Max SPL	128dB @1m/4Pi
Freq Range -10	45Hz - 20kHz
Freq Range -3	55Hz - 20kHz
Hor Dispersion	90°
Vert Dispersion	60°
Power Rating	1300W peak / 650 RMS
AC Power Input	100V-120V or 220V-240V
Cooling	Passive
LED Indicators	1 Power LED, 1 Limit LED, 1 Front LED, 2 Signal/SSM LEDs
Input Impedance	50k/100k un-balanced/balanced
Input Gain	-∞ to +36db
Crossover Freq	1.9 kHz
I/O	2 XLR Combo Jacks / BT 1 XLR M Thru
Cabinet	PP+10% Talc
Grille	16GA perforated steel with acoustically transparent black cloth backing
Suspension/Mount	4 M10 Suspension points, 36mm Pole Socket, universal yoke bracket holes
Handles	2, cable channel on bottom
Net Weight	17kg
Gross Weight	21.5kg
Product DIMS	716x438x358mm 28.1x17.24x14.9in (HxWxD)
Shipping DIMS	738x543x458mm 29.1x21.4x18in (HxWxL)

EON718S SPECIFICATIONS

TECHNICAL SPECIFICATIONS

System Type	18IN Powered Subwoofer
Woofers Model	718G
Woofers Size	18"
Woofers Magnet	Ferrite
Woofers Voice Coil	3"
Transducer Impedance	4 ohm rated
Max SPL	131dB @1m/2Pi
Freq Range -10	31Hz - 150Hz
Freq Range -3	40Hz -120Hz
Hor Dispersion	Omni
Vert Dispersion	Omni
Crossover Frequency	80, 100, 120Hz selectable
Power Rating	1500W / 750W RMS
AC Power Input	100V-120V or 220V-240V
Cooling	Passive
LED Indicators	1 Power LED, 1 System Limit, 1 Front LED
Input Impedance	50k/100k un-balanced/balanced
Input Gain	-∞ to +36db
I/O	2 XLR Combo 2 XLR M Thru
Cabinet	18mm Duraflex-coated Birch Plywood
Grille	16GA perforated steel with acoustically transparent black cloth backing
Suspension/Mount	1 M20 Threaded Polecup
Handles	2
Net Weight	35.5kg
Gross Weight	42.5kg
Product Dims	674x609x637mm 26.53x24x25.1in(HxWxD)
Shipping Dims	722x743x713mm 28.4x29.3x28.1in (HxWxL)

CABLES & CONNECTORS

XLR/F to XLR/M Microphone Cable	The standard cable for interconnection of microphone and line level signal in professional audio systems. • Microphone to mixer
TRS (balanced) 1/4 inch (6.35mm) phone jack to XLR/M	For connecting balanced devices with 1/4 inch (6.35mm) phone and maybe used interchangeably.
TRS (unbalanced) 1/4 inch (6.35mm) phone jack to XLR/M	For connections of instruments with unbalanced outputs to balanced XLR inputs.
TS (unbalanced) 1/4 inch phone (6.35mm) jack to XLR/M	This cable is electrically identical to "TRS" (unbalanced) 1/4 inch (6.35mm) phone and may be used interchangeably.
XLR/M to RCA (phono) cable	Connects consumer audio products and some DJ mixer outputs to professional audio equipment inputs
TRS 1/4 inch Phone jack to dual 1/4 inch (6.35mm) Phone jack	Splits a stereo output into separate left/right signals.
TRS 1/4 inch Phone jack to dual 1/4 inch (6.35mm) Phone jack	Change to a TRS mini-phone jack to connect to the output of a portable. MP3/CD – player and computer sound cards to a mixer.
XLR/F to XLR/M audio ground lift	Only with balanced in - and outputs

XLR/F to XLR/M Microphone Cable

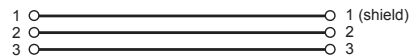

TRS (Balanced) 1/4" Phone to XLR/M Cable



TRS (Unbalanced) 1/4" Phone to XLR/M Cable

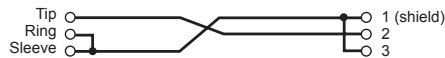

TS (Unbalanced) 1/4" Phone to XLR/M Cable



XLR/M to RCA (Phono) Cable

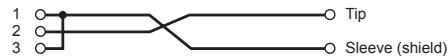

TS (Unbalanced) 1/4" Phone to RCA (Phono) Cable

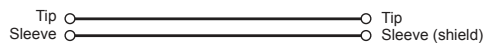

TRS 1/4" Phone to dual TS 1/4" Phone Cable

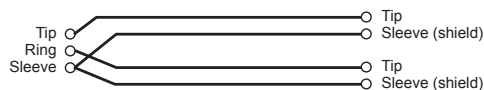

XLR/F to XLR/M Audio Ground Lift Adapter

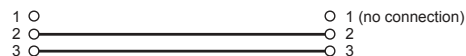
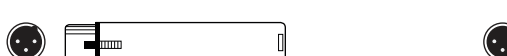

CONTACT INFORMATION



Mailing Address:

JBL Professional
8500 Balboa Blvd.
Northridge, CA 91329

Shipping Address:

JBL Professional
8500 Balboa Blvd., Dock 15
Northridge, CA 91329
(Do not return product to this address without first obtaining prior authorization from JBL)

Customer Service:

Monday through Friday
8:00am -5:00pm
Pacific Coast Time in the U.S.A.

(800) 8JBLPRO (800.852.5776)

www.jblproservice.com

On The World Wide Web:

www.jblpro.com

Professional Contacts, Outside the USA:

Contact the JBL Professional Distributor in your area.
A complete list of JBL Professional international distributors is provided at our U.S.A. website: www.jblpro.com

WARRANTY INFORMATION

The JBL Limited Warranty on professional loudspeaker products (except for enclosures) remains in effect for five years from the date of the first consumer purchase. JBL amplifiers are warranted for three years from the date of original purchase. Enclosures and all other JBL products are warranted for two years from the date of original purchase.

Who Is Protected By This Warranty?

Your JBL Warranty protects the original owner and all subsequent owners so long as: A.) Your JBL product has been purchased in the Continental United States, Hawaii or Alaska. (This Warranty does not apply to JBL products purchased elsewhere except for purchases by military outlets. Other purchasers should contact the local JBL distributor for warranty information.); and B.) The original dated bill of sale is presented whenever warranty service is required.

What Does The JBL Warranty Cover?

Except as specified below, your JBL Warranty covers all defects in material and workmanship. The following are not covered: Damage caused by accident, misuse, abuse, product modification or neglect; damage occurring during shipment; damage resulting from failure to follow instructions contained in your Instruction Manual; damage resulting from the performance of repairs by someone not authorized by JBL; claims based upon any misrepresentations by the seller; any JBL product on which the serial number has been defaced, modified or removed.

Who Pays For What?

JBL will pay all labor and material expenses for all repairs covered by this warranty. Please be sure to save the original shipping cartons because a charge will be made if replacement cartons are requested. Payment of shipping charges is discussed in the next section of this warranty.

How To Obtain Warranty Performance

If your JBL product ever needs service, write or telephone us at JBL Incorporated (Attn: Customer Service Department), 8500 Balboa Boulevard, PO. Box 2200, Northridge, California 91329 (818/893-8411). We may direct you to an authorized JBL Service Agency or ask you to send your unit to the factory for repair. Either way, you'll need to present the original bill of sale to establish the date of purchase. Please do not ship your JBL product to the factory without prior authorization. If transportation of your JBL product presents any unusual difficulties, please advise us and we may make special arrangements with you. Otherwise, you are responsible for transporting your product for repair or arranging for its transportation and for payment of any initial shipping charges. However, we will pay the return shipping charges if repairs are covered by the warranty.

Limitation of Implied Warranties

ALL IMPLIED WARRANTIES, INCLUDING WARRANTIES OF MERCHANTABILITY AND FITNESS FOR PARTICULAR PURPOSE, ARE LIMITED IN DURATION TO THE LENGTH OF THIS WARRANTY.

EXCLUSION OF CERTAIN DAMAGES

JBL'S LIABILITY IS LIMITED TO THE REPAIR OR REPLACEMENT, AT OUR OPTION, OF ANY DEFECTIVE PRODUCT AND SHALL NOT INCLUDE INCIDENTAL OR CONSEQUENTIAL DAMAGES OF ANY KIND. SOME STATES DO NOT ALLOW LIMITATIONS ON HOW LONG AN IMPLIED WARRANTY LASTS AND/OR DO NOT ALLOW THE EXCLUSION OF INCIDENTAL OR CONSEQUENTIAL DAMAGES, SO THE ABOVE LIMITATIONS AND EXCLUSIONS MAY NOT APPLY TO YOU. THIS WARRANTY GIVES YOU SPECIFIC LEGAL RIGHTS, AND YOU MAY ALSO HAVE OTHER RIGHTS, WHICH VARY, FROM STATE TO STATE.

JBL Professional

8500 Balboa Blvd. Northridge, CA 91329 USA

EON 700

SERIES