

Instruction Manual

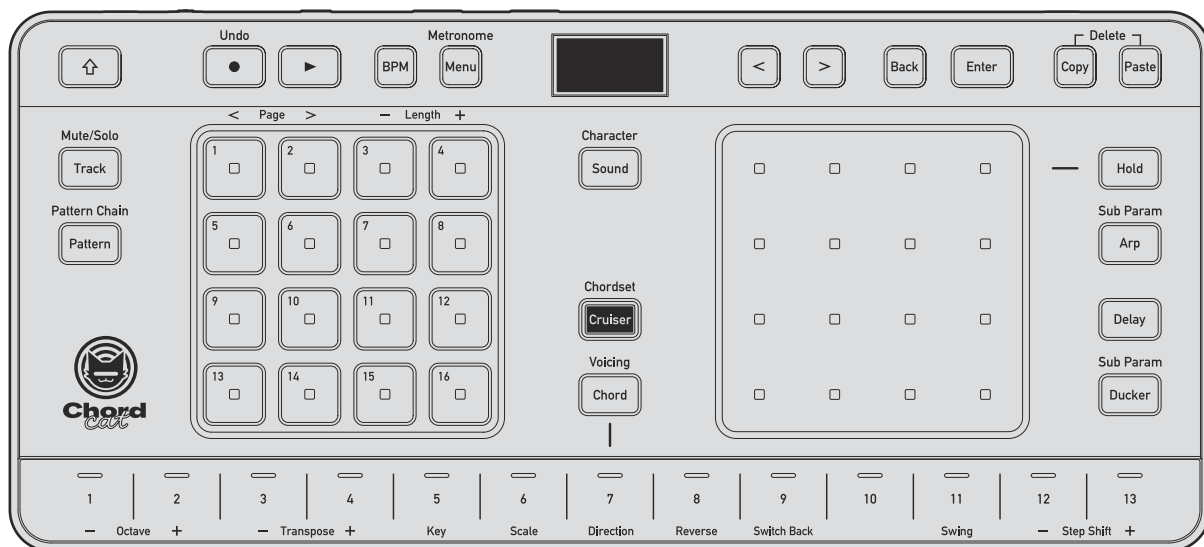

Groovebox

CHORDCAT

alphatheta.com/support/

For FAQ and other support information for this product, visit the website above.

TORAIZ

How to read this manual

Be sure to read this manual and the Quick Start Guide and Precautions for Use, which are also included with this product.

These documents include important information that you should understand before using the product.

Descriptions in this manual

- In this manual, the names of the buttons and terminals displayed on the main unit, and the menu names etc. displayed on the main unit display are as written as follows.

Terminal names

USB terminal, **MIDI OUT/THRU** terminal

Button names

[**Menu**] button, [**Sound**] button, [⏪] button, step button [6]

Names of items on the main unit display

Project, **Create New**

- The screens and specifications of the main unit display that are referenced in this document, and the exterior and specifications of the hardware, are currently in development and may differ from the final specifications. Your understanding is appreciated.

What's in the box

- Main unit x 1

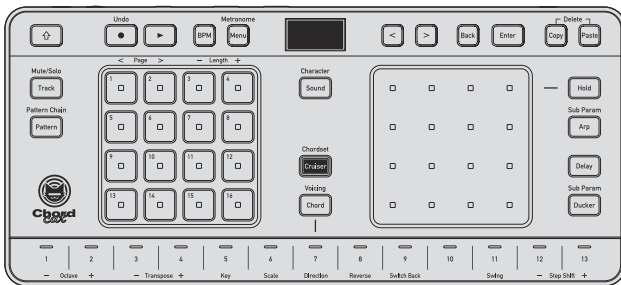

- USB cable x 1
(USB 2.0 Type-C plug – USB Type-C plug)
- Quick Start Guide x 1
- Precautions for Use x 1
- Warranty (some regions)^{*1} x 1

*1 Only for products for the European market. (The warranty for Japan and North America is printed in the Precautions for Use.)

Contents

Introduction

How to read this manual	2
What's in the box	2
Contents	3
Characteristics of this product	6
Auto power off function	6

Quick Start

Overall flow	7
--------------------	---

Names and Functions of Each Part

Top panel	13
Rear/side of the main unit	15
Rear	15
Side	16

Preparing Projects

Sequencer	17
What is a project?	17
From creating projects to performing	18
Creating a new project	19
Saving the project	19
Overwriting and saving the project	19
Saving the project with a different name	20
Loading a previous project	21
Changing the name of a project	22
Deleting a project	23

Frequently Used Basic Operations

Frequently used basic operations for creating songs	24
Selecting a track	24
Selecting a pattern	25
Changing the BPM	26
Setting the keyboard scale	27
Entering notes in steps, one at a time	30
Entering a performance in real time	32

Creating Drum Patterns

Creating drum patterns	34
Adjusting the volume of each instrument in the drum kit	36

Creating Chord Patterns

Creating chord patterns	37
Setting chords for Chord Performance mode	39
Assigning candidate voicing chords	39
Assigning candidate progression chords	41

Creating Melody Patterns

Creating melody patterns	42
--------------------------------	----

Editing Steps

Turning triggers on/off	44
Previewing the notes entered to the step buttons	44
Making detailed sound adjustments	45
Adjusting individual steps	45
Editing a whole pattern	46

Editing Patterns

Adding/removing pattern pages.....	46
Moving to the next/previous pattern page.....	47
Connecting two or more patterns	47
Stopping pattern chain playback.....	48

Creating Patterns Efficiently

Using the copy/paste function.....	49
Copying and pasting tracks	49
Copying and pasting patterns	49
Copying and pasting notes recorded to the step buttons.....	50
Copying and pasting chords	52
Using the delete function	53
Deleting step button settings	53
Deleting patterns	54
Deleting chords assigned to the keyboard.....	54
Using the undo function	54

Adjusting the Character of Sound Presets

Adjusting the low-pass filter.....	55
Adjusting the amplifier envelope.....	56
Setting how the sound is produced (mono/poly).....	57
Setting portamento time	58

Adjusting Track Parameters

Adjusting the volume and left/right stereo localization of a track.....	58
Adjusting the volume	58
Adjusting the pan	59
Setting the level of effects applied to each track	60
Applying reverb.....	60
Applying chorus.....	60
Switching between mute and solo on each track.....	61

Arranging Patterns

Changing the direction of sequence progression to create new phrases	62
Setting the sequence progression direction (running direction).....	62
Reversing the playback order of the steps.....	63
Reversing the direction and replaying the steps from the end	63
Shifting steps to create new phrases.....	64
Using swing to create a groove.....	65
Using effects to add arrangements to phrases	66
Using the arpeggiator	66
Using delay	69
Using the ducker	70

Using the Product with External MIDI Devices and Computers

Connecting this product to an external MIDI device for performances	72
Controlling a computer or external MIDI device from this product (using MIDI OUT)	73
Controlling this product or an external MIDI device from a computer	74

Operating the Settings Menu

Operating the menu screen	75
How to operate the menu screen	75
Setting items list	76
Adjusting the brightness of the main unit display	77
Adjusting the brightness of the control LEDs	77
Setting MIDI input	77
Setting MIDI output	78
Setting tracks for MIDI input/output	81
Finely adjusting reverb and chorus	82
Setting the step preview method	84
Changing the auto power off setting	84
Resetting all menu setting items to their defaults	85
Displaying system information	85

Other

Troubleshooting	86
Detailed project structure	89
Trademarks and registered trademarks	90
Licenses	90
Specifications	91

Characteristics of this product

This product is a standalone groovebox capable of creating a variety of phrases with chords, melodies, and drums. Its most outstanding feature is Chord Cruiser, which you can use to easily create impressive chord progressions, regardless of your musical knowledge or ability to play a musical instrument. Play a few chords on this product and Chord Cruiser will recommend more chords that suit them. You can then choose the ones that give you the sound you're trying to create. This product can even run on battery power, so you can enjoy music production anytime, anywhere you want.

Auto power off function

This product is equipped with an auto power off function.

The auto power off function is activated by default and will turn the power off automatically if no signal is input or output and no operation is performed for approximately 20 minutes. To turn the power on after it's been turned off automatically, press the [⏻] button on the rear of the main unit.

To deactivate the auto power off function, refer to the following and change the settings.

▶ “Changing the auto power off setting” (p. 84)

Note

-
- Deactivating the auto power off function will increase power consumption.
-

Overall flow

First, to help you get used to using this product, go through the overall operation while using the preset programs.

1. Connect the device.

This product can run on batteries or on power supplied through its **USB** terminal. Use commercially available AA alkaline dry-cell batteries.

- When the USB cable is connected, power is supplied via the USB terminal, even if the product has batteries loaded.
- Inserting or removing the USB cable may cause the power to be cut even if there are batteries loaded, so be sure to turn off the product power before doing so.

To run on batteries

Open the rear cover and insert six AA batteries.

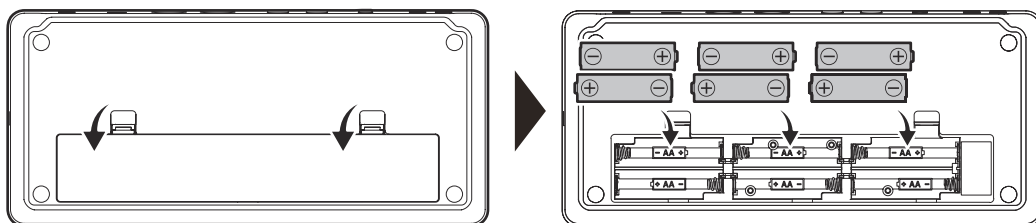

⚠ Warning

- Comply with local government instructions (ordinances) when disposing of unneeded batteries.
- Do not use or leave batteries in a location subject to high temperatures, such as exposed to direct sunlight, in a vehicle under hot sun, or in front of a heater. Doing so may cause battery leakage, overheating, rupture, or fire. It may also degrade battery performance or shorten battery life.
- Take note of battery polarity (\oplus , \ominus), and insert batteries as indicated. Do not use any batteries other than those specified, or use new batteries together with old ones. Doing so may cause battery rupture or leakage, resulting in injury or contamination of the surrounding area.
- Do not bend the negative spring contacts by pushing them when inserting batteries. Doing so may cause batteries to short-circuit, leak, or generate heat.

⚠ Cautions

- Be sure to use commercially available 1.5-V dry-cell batteries or batteries designated in the Instruction Manual.
- Please carefully read the warnings indicated on the batteries and use the batteries correctly.
- Be sure to close the battery cover when using the product.

To run on power from a USB connection

Connect the supplied cable to the **USB** terminal of the product. Connect the other end of the cable to a device that will supply the power, such as a computer.

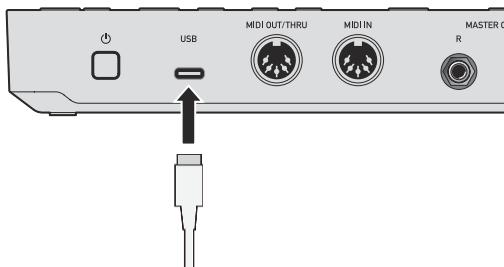

Connecting speakers or headphones

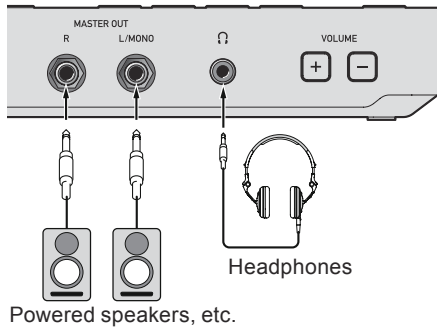

2. Turn the product power on.

Press and hold the power button on this product to turn on the power. The product's display and LEDs light up when it's turned on.

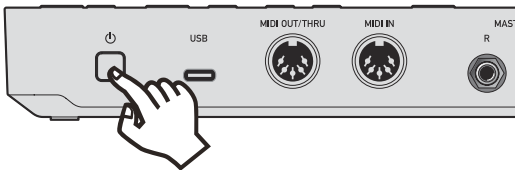

3. Load the demo project.



① Press the [Menu] button to open the menu screen.

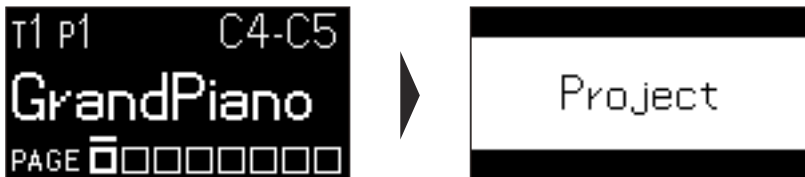

Project appears on the main unit display.

Note

- If **Project** does not appear, press the [<] button to display **Project**.

② Press the [Enter] button.

③ Press the [<] or [>] button, select **Open(name)**, and press the [Enter] button.



- ④ Press the [<] or [>] button to select a demo project of your choice (Example: DemoProject1), and press the [Enter] button.

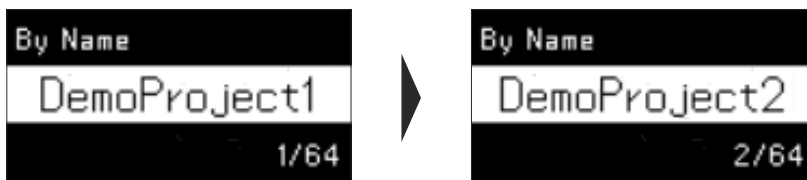

The selected project is called up.

- ⑤ Press the [<] or [>] button, select **OK**, and press the [Enter] button.

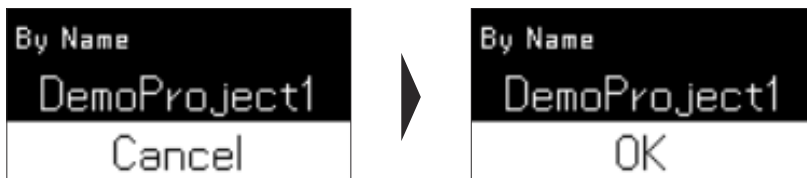

The called project is loaded.

- ⑥ Press the [Menu] button to close the menu screen.

The main unit display returns to the Sequence mode screen.

This loads the demo project. You can use any of the performance features.

4. Play/stop the project.

Try playing the project (loaded demo project). Immediately after loading the project, pattern 1 of track 1 is selected.

- ① Press the [Play] button.



The [Play] button lights up and sequencer playback starts.

When sequencer playback starts, the sequencer plays 16 steps in sequence. The button lit in white indicates the current playback position. By default, each step is played in order, as shown below.

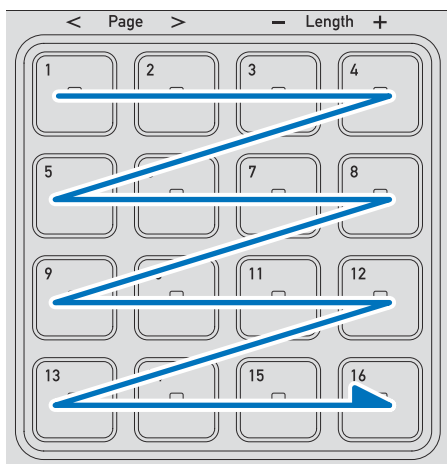

② Press the [Play] button again.

The [Play] button lights up in a dim green and sequencer playback stops.

5. Perform using the keyboard.

You can play music on the product using the keyboard.

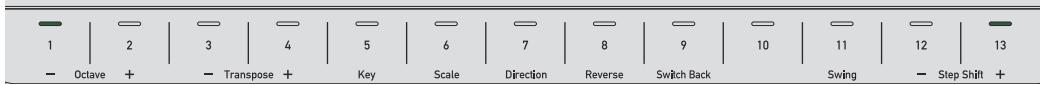

Do the following to record your keyboard performance in real time.

① Press the [Rec] button.



Recording starts.

② Press the [Play] button to start sequencer playback.



Sequencer playback starts.

③ Perform on the keyboard, matching your timing to the sequencer.

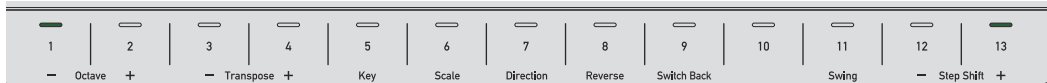

Your performance is saved and played.

6. Perform using chords.

You can play chords easily on this product.

Note

- Scales are used to play chords. Select a sound preset that is not a single-note (bass, etc.) preset.

① Press the [Chord] button.

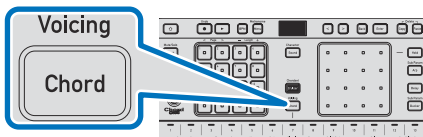

When you touch a keyboard touch key, a chord is output.

While you're touching the keyboard touch key, the current chord is displayed on the main unit display.

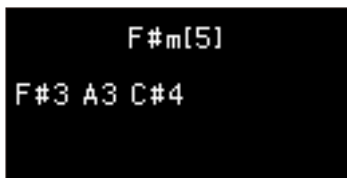

7. Use the Chord Cruiser function to set a chord progression.

Normally, it takes musical knowledge to create a song progression using chords, but the Chord Cruiser function makes it easy to use the keyboard to craft beautiful chord progressions.

- 1 Press the [Cruiser] button.

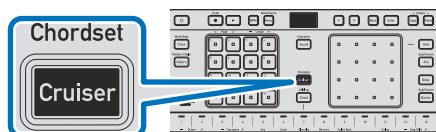

The [Cruiser] button lights up and the product enters Chord Cruiser mode.

- 2 Touch the keyboard.

The touch key flashes and the next candidate matching the chord that's playing lights up on the XY pad. (If a page has fewer than 16 candidates, positions that were not assigned one do not light up.)

Brightly lit positions: Chords in the scale of the currently selected key

Dimly lit positions: Chords not in the scale of the currently selected key

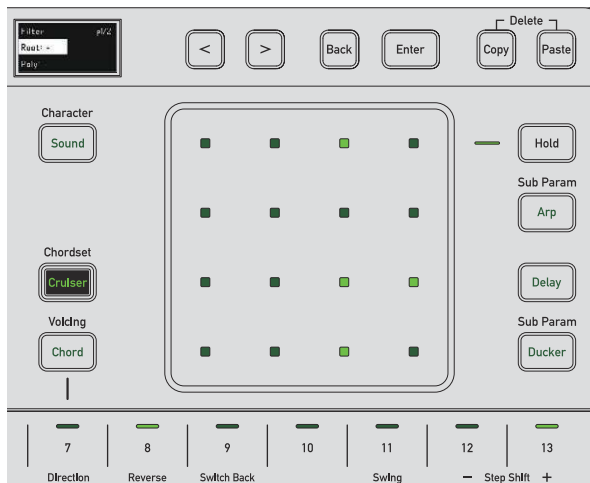

- 3 Touch the positions lit up on the XY pad.

Touching the XY pad plays the chord, which is displayed on the main unit display as the next chord candidate.

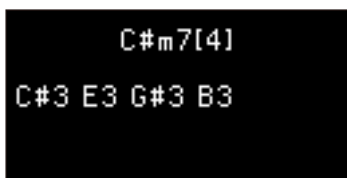

Touching other positions lit up on the XY pad plays other chords.

Touch the lit positions on the XY pad to search for the chord you want to assign to the keyboard touch key.

- ④ **While touching a lit position on the XY pad, touch one of the touch keys that are flashing on the keyboard.**

This assigns the chord you want to use next to the relevant touch key on the keyboard.

- ⑤ **Repeat steps (2) to (4) to create the layout you want.**

This assigns only the chords you want to use in the chord progression you're creating to touch keys on the keyboard.

8. Change the sound preset.

You can change the sound preset (instrument) played by each track.

- ① **Press the [Sound] button.**



The sound preset selection screen appears on the main unit display.

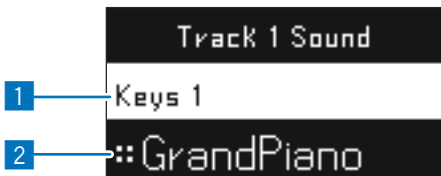

- ① Currently selected sound category

(In the example shown above, the category selected is “Keys 1,” which features a collection of keyboard instruments.)

- ② Currently selected sound preset

(In the example shown above, the sound selected is “Grand Piano”, one of the sounds in “Keys 1.”)

- ② **Press the [<] or [>] button to select a sound category.**

- ③ **Touch the XY pad to select a sound preset.**

Select the sound preset you want the track to play.

9. Change the BPM.

You can change the BPM (speed of the music).

- ① **Press the [BPM] button.**

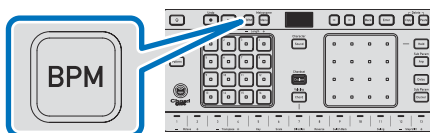

The BPM value appears on the main unit display.

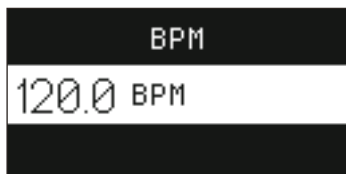

- ② **Press the [<] or [>] button.**

Increasing the BPM value speeds up the tempo, and lowering it reduces the tempo.

Note

- Tap the **[BPM]** button repeatedly to set the BPM to the interval at which you tapped the button.

3 Press the [Enter] button.

The BPM is confirmed and the screen returns to the previous screen.

Note

- During setting of the BPM, if the **[BACK]** button is pressed or if no operation is performed for 5 seconds, setting of the BPM will be canceled.

Top panel

The locations and names of the buttons and terminals used to operate this product are as follows.

Explanations with (⇧ button + button name) mean you should press the ⇧ button (Shift button) while pressing the relevant button to perform the operation.

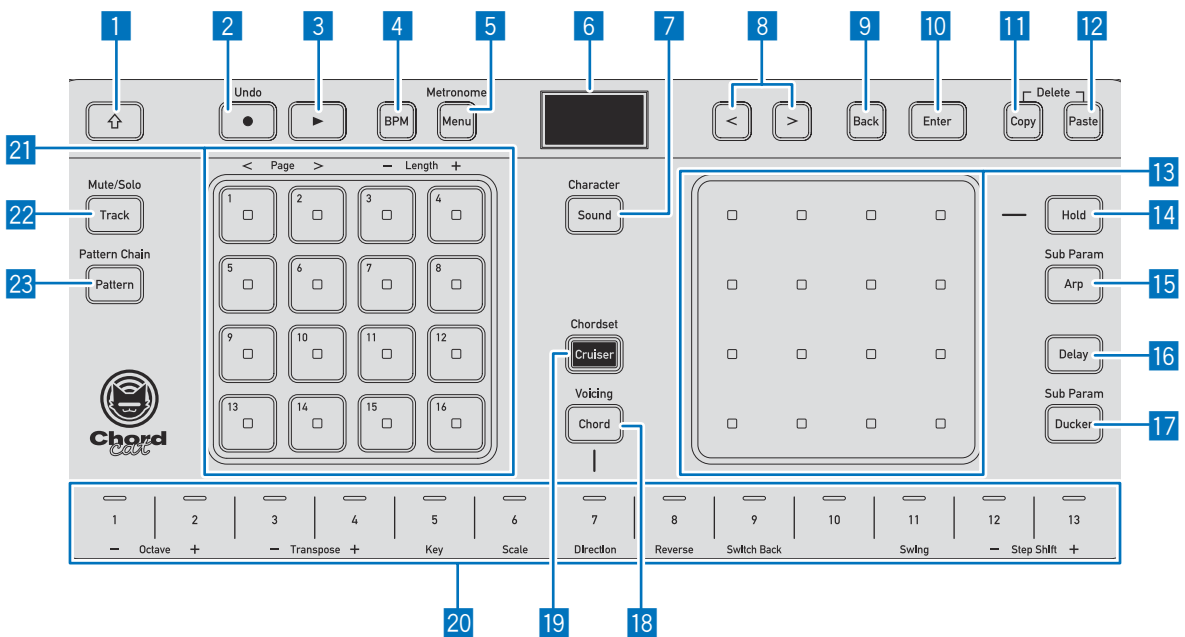

1 ⇧ button (Shift button)

When multiple functions are assigned to a button, press that button while pressing the Shift button to activate an alternate function.

2 Rec button

Press this button to light it up and enable recording. Your performance is recorded while the sequencer plays. (⇧ button + Rec button) Cancels the previous operation. (Undo function)

3 Play button

Plays the sequencer. Press during sequencer playback to stop it.

4 BPM button

Changes the BPM value (speed of the music).

5 Menu button

Opens the menu screen.

(⇧ button + Menu button) Turns the click sound on/off. (Metronome function)

6 Main unit display

Displays menus and statuses.

Names and Functions of Each Part

- 7 Sound button**
Changes the sound preset.
(↑ **button + Sound button**) Gives you options to make detailed changes to the selected sound preset.
- 8 < > buttons**
Selects the previous/next item in the menu or other operation.
- 9 Back button**
Moves one step back in the menu.
- 10 Enter button**
Confirms an item in the menu.
- 11 Copy button**
You can copy track parameters, patterns, steps, and chord assignments.
- 12 Paste button**
Pastes items copied using the [**Copy**] button.
- 13 XY pad**
Use this to adjust parameters and select items in each mode.
- 14 Hold button**
Keeps the position of the last operation on the XY pad when applying an effect.
- 15 Arp button**
Sets the speed and length of single arpeggiator notes.
(↑ **button + Arp button**) Enables you to set arpeggiator octave ranges and arpeggiator patterns.
- 16 MIDI Note Delay button**
You can adjust the delay time and feedback level.
- 17 Ducker button**
Sets the ducking period and depth.
(↑ **button + Ducker button**) You can set the time until the ducking effect begins, and the moderation of the effect.
- 18 Chord button**
Press this, then play chords on the keyboard.
(↑ **button + Chord button**) Candidate voicing chords for the chord played on the keyboard are shown on the XY pad.
- 19 Cruiser button**
Candidate chords for song progressions matching the chord played on the keyboard are shown on the XY pad.
(↑ **button + Cruiser button**) Select a set of chords that'll be suggested to the keyboard for chord playing.
- 20 Keyboard**
You can play this like a keyboard.
(↑ **button + buttons [1] to [6]**) Raises or lowers the keyboard octave, or sets the key or scale.
(↑ **button + buttons [7] to [13]**) Sets the amount of swing or the direction of sequence progression for the step button.
- 21 Step buttons**
Each button is a single step in the sequence. When the sequence plays, each step is triggered in order. When notes are assigned, the buttons are lit up in a bright green, and during a rest (when nothing is assigned), they are lit in a dim green. When the sequencer is playing, the button for the current step is lit in white. Also, in Track Selection mode or Pattern Selection mode, these buttons are used to select tracks or patterns.
- 22 Track button**
Use this to select the track to set.
(↑ **button + Track button**) You can switch between mute and solo for each track.
- 23 Pattern button**
You can select a pattern from up to 16 patterns in the currently selected track.
(↑ **button + Pattern button**) You can assign a playback order to patterns for sequencer playback. (Pattern chain)

Rear/side of the main unit

Rear

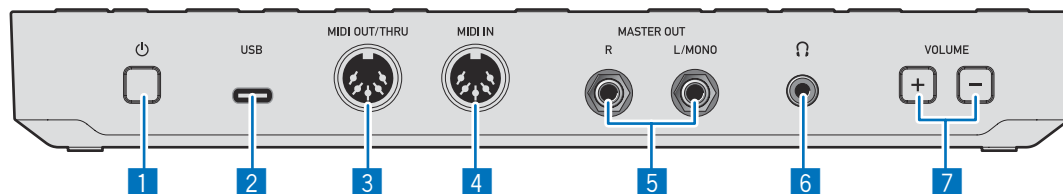

1 **⏻ (Power) button**

Press and hold to turn the product power on/off.

2 **USB terminal (USB 2.0 Type-C)**

Connect to a computer. Power is supplied via USB bus power.

Note

- This product cannot be used with a USB hub.
- To maintain performance, directly connect the product and the computer with a USB 2.0-compliant USB cable.
- You can use the dedicated application and updater to send and receive standard MIDI files and project data via the USB terminal, and to update the product firmware version.
- When restarting the computer connected to the product via USB, be sure to turn off the product power before performing the restart.

3 **MIDI OUT/THRU terminal**

Connect to a device to send MIDI signals from the product to the device.

4 **MIDI IN terminal**

Connect to a device that will send MIDI signals to the product.

5 **MASTER OUT terminal (R, L/MONO)**

Connect to the analog input terminal on a power amplifier or mixer. Output from a 1/4" TS jack is unbalanced. For mono output, connect to the L/MONO side only.

6 **🎧 (Headphones) terminal**

Connect headphones. Only compatible with stereo mini plug (3.5 mm (1/8") dia., 3-pole).

7 **VOLUME buttons (+/-)**

Adjust the volume output from the product. These buttons adjust the volume for both the MASTER OUT and headphone terminals.

Names and Functions of Each Part

Side

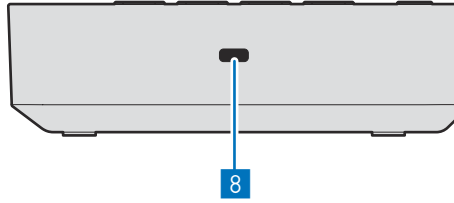

8 Hole for Kensington lock

You can connect a commercially available anti-theft cable (wire) compatible with Kensington security locks.

Sequencer

A sequencer is a system that plays notes in order, according to how you perform a song, similar to following sheet music. The sequencer in this product can set to play or not play notes for each individual step.



Assigning a sound preset to a step will cause a sound to be played when the sequencer reaches that step during playback. The sound preset in this example is a drum, but melodies can be created by assigning an instrument with a scale.

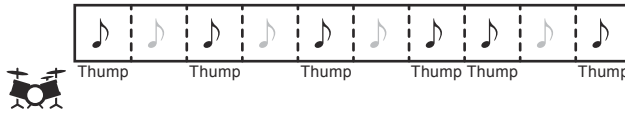

On this product, steps with a fixed length such as this are called “patterns.”

What is a project?

On this product, songs are managed in units called “projects.” A project can have up to eight tracks, with 16 patterns for each track.

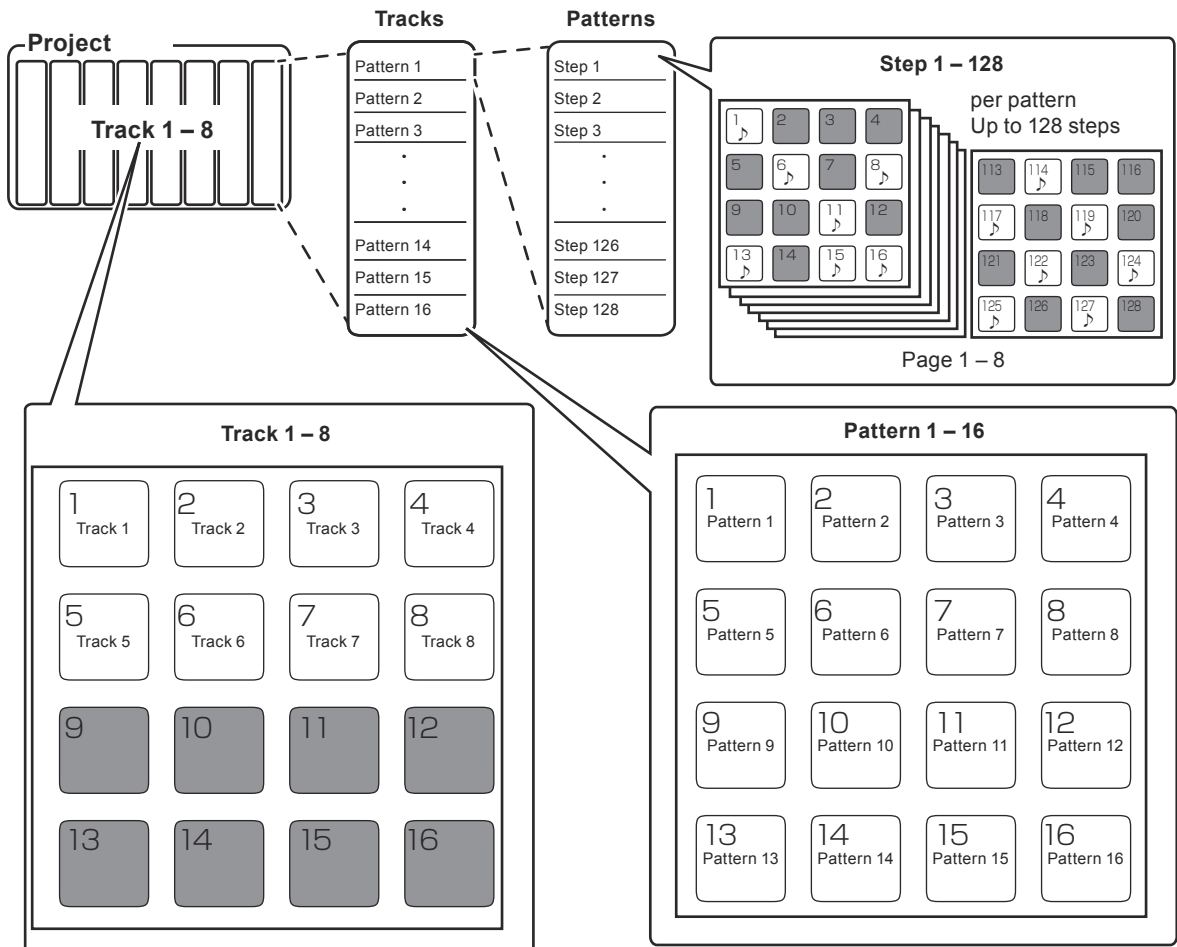

Refer to the following for a detailed project structure.

► “Detailed project structure” (p. 89)

From creating projects to performing

Create a project



Songs are managed in this product in units called “projects.” First, create a project that will become a song.



Select a track and choose an instrument (sound preset)



Initially, it’s a good idea to create tracks to give yourself a drum pattern (percussion instruments), chord pattern (string instruments), and melody pattern (keyboard instruments).

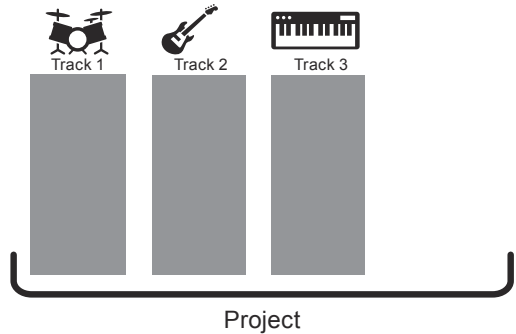

What is a track?

You can assign one sound preset – which equates to an instrument – per track. You can change the assignment of sound presets later. On this product, one project can contain up to eight tracks.

Create a pattern



Create patterns in each track. There are two ways of entering data to create a pattern – step entry and real-time entry.

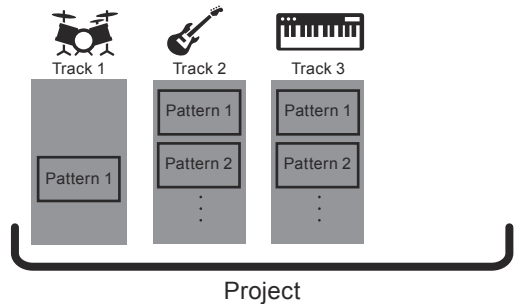

What is a pattern?

Patterns consist of 16 to 128 steps. In a drum pattern, for example, a single pattern might be created with kick notes entered on the first and third beats and snare notes on the second and fourth beats. For scale-based instruments, a pattern can comprise a single melody or chord.

Add tracks and patterns to an arrangement



Change the direction of the sequencer progression, use effects, or use the pattern chain function to create tracks.

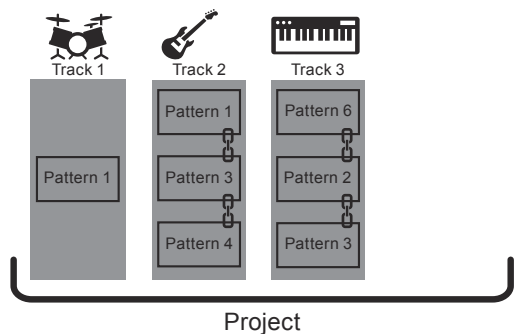

Play a project to perform



When your project is ready, try playing it on the sequencer. You can enjoy listening to your song with all tracks playing at the same time.

Creating a new project

1. Press the [Menu] button.

The menu screen appears.

2. Press the [<] or [>] button to select **Project**, and press the [Enter] button.



3. Press the [<] or [>] button to select **Create New**, and press the [Enter] button.



4. Press the [<] or [>] button to select **OK**, and press the [Enter] button.



Note

- Select **Cancel** and press the [Enter] button to cancel project creation and return to the previous screen.

Saving the project

Overwriting and saving the project

You can overwrite the currently open project to save it.

1. Press the [Menu] button.

The menu screen appears.

Preparing Projects

2. Press the [←] or [→] button to select **Project**, and press the [Enter] button.



3. Press the [←] or [→] button to select **Save**, and press the [Enter] button.



4. Press the [←] or [→] button to select **OK**, and press the [Enter] button.



The project is saved.

Note

- Select **Cancel** and press the [Enter] button to cancel saving and return to the previous screen.

Saving the project with a different name

You can rename the currently open project and save it as a separate project.

1. Press the [Menu] button.

The menu screen appears.

2. Press the [←] or [→] button to select **Project**, and press the [Enter] button.



3. Press the [←] or [→] button to select **Save As**, and press the [Enter] button.



4. Enter the name of the project to save.

The current project name appears on the main unit display. The cursor (the framed area) appears.



Press the [**<**] or [**>**] button to change the character in the cursor position.

The character changes each time you press a button. When the display reaches the first or last character of that type, the character displayed switches to the next type. Character types that can be entered are numbers, uppercase letters, lowercase letters, and certain symbols.

- To move the cursor: [**↑**] button + [**<**] button or [**↑**] button + [**>**] button
- To delete the character in the cursor position: [**↑**] button + [**Back**] button
- To insert a space in the position before the cursor: [**↑**] button + [**Enter**] button

5. When you've finished entering the name, press the [**Enter**] button.

The project is saved.

Loading a previous project

1. Press the [**Menu**] button.

The menu screen appears.

2. Press the [**<**] or [**>**] button to select **Project**, and press the [**Enter**] button.



3. Press the [**<**] or [**>**] button to select **Open(recent)**, **Open(creation)**, or **Open(name)**, and press the [**Enter**] button.

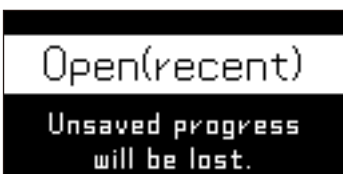

Select **Open(recent)** to sort projects by the order in which they were opened.

Select **Open(creation)** to sort projects by the order in which they were created.

Select **Open(name)** to sort projects alphabetically.

Preparing Projects

4. Press the [**<**] or [**>**] button to select a project, and press the [**Enter**] button.



5. Press the [**<**] or [**>**] button to select **OK**, and press the [**Enter**] button.

The project is loaded.

Note

- Select **Cancel** and press the [**Enter**] button to cancel loading and return to the previous screen.

Changing the name of a project

Change the name of the currently open project and save the edited content.

1. Press the [**Menu**] button.

The menu screen appears.

2. Press the [**<**] or [**>**] button to select **Project**, and press the [**Enter**] button.



3. Press the [**<**] or [**>**] button to select **Rename Save**, and press the [**Enter**] button.



4. Enter the new name of the project.

The current project name appears on the main unit display. The cursor (the framed area) appears.



For details on how to enter characters, refer to the following.

- ▶ "Saving the project with a different name" (p. 20)

5. When you've finished entering the new name, press the [**Enter**] button.

The project is saved.

Deleting a project

1. Press the [Menu] button.

The menu screen appears.

2. Press the [<] or [>] button to select **Project**, and press the [Enter] button.



3. Press the [<] or [>] button to select **Delete**, and press the [Enter] button.



4. Press the [<] or [>] button to select a project to delete, and press the [Enter] button.



5. Press the [<] or [>] button to select **OK**, and press the [Enter] button.



The project is deleted.

Note

- Press the [<] or [>] button to select **Cancel**, and press the [Enter] button to cancel deletion and return to the previous screen.

Frequently used basic operations for creating songs

The following is a detailed explanation of the operations for switching modes when creating songs.

Selecting a track

You can use up to eight tracks. Normally, different instruments are assigned to each track. The following example explains how to select track 2.

1. Press the [Track] button.



The [Track] button lights up and the product enters Track Selection mode. While the [Track] button is lit, the product is in Track Selection mode.

The step button for the currently selected track (one of buttons [1] to [8]) lights up in a bright green. Step buttons lit in a dim green indicate tracks that can be selected.

Tracks are assigned to the step buttons as follows.

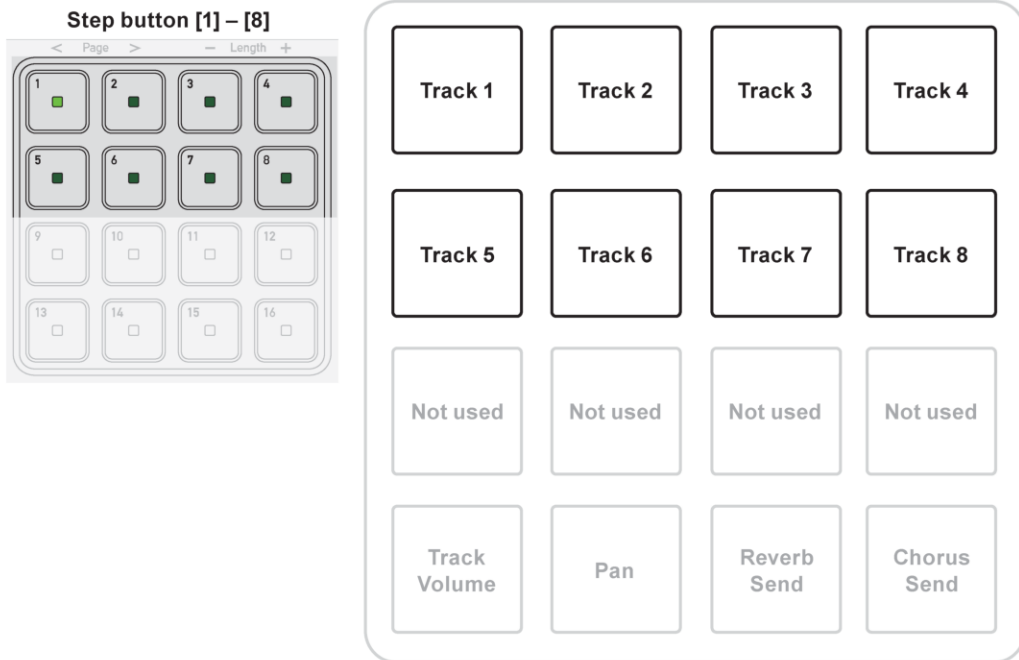

In the diagram above, track 1 is selected.

The main unit display also shows that track 1 is selected.



2. Press one of the step buttons to select a track to edit.

To select a track, press one of the step buttons marked [1] to [8].

For example, when step button [2] is pressed, step button [2] lights up and track 2 is selected.



The main unit display shows that track 2 is selected.



3. Press the [Track] button again.

The product exits Track Selection mode and returns to Sequence mode.

Selecting a pattern

You can set up to 16 patterns per track. Saving a number of different phrases as patterns increases the amount of available performance variations.

1. Press the [Pattern] button.

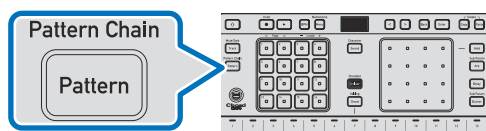

The [Pattern] button lights up and the product enters Pattern Selection mode. Whenever the [Pattern] button is lit, the product is in Pattern Selection mode.

The step button for the currently selected pattern (one of buttons [1] to [16]) lights up in a bright green. Buttons are lit in a dim green when an edited pattern is stored, while unlit step buttons indicate that no pattern is stored.

Frequently Used Basic Operations

Patterns are assigned to the step buttons as follows.

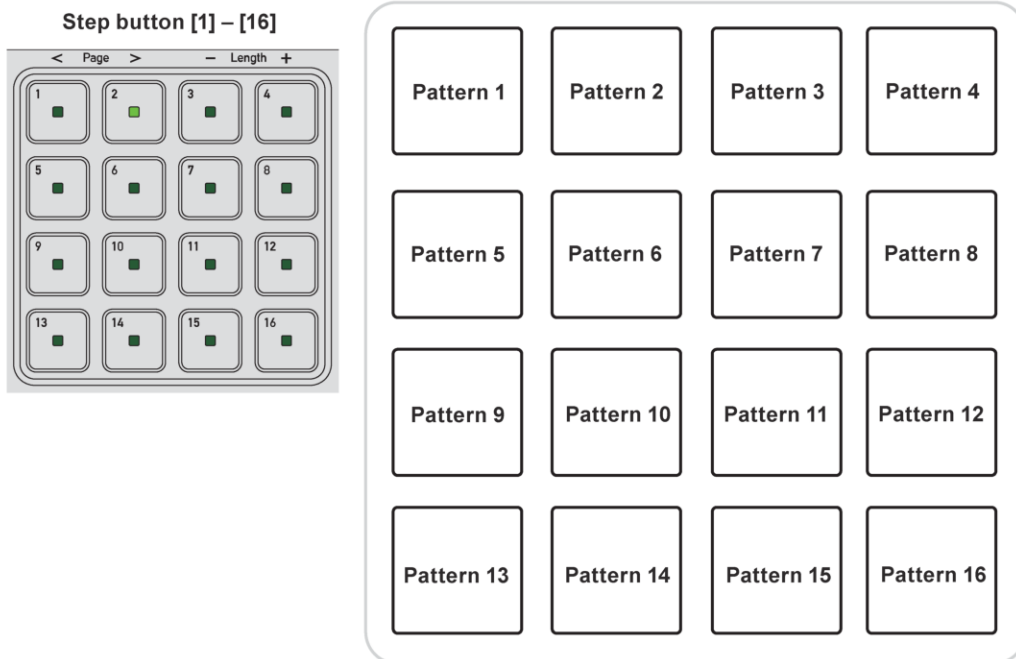

In the diagram above, pattern 2 is selected.
The main unit display also shows that pattern 2 is selected.



2. Press one of the step buttons to select a pattern to edit.

To select a pattern, press one of the step buttons marked [1] to [16].
For example, when step button [3] is pressed, step button [3] lights up and pattern 3 is selected.



3. Press the [Pattern] button again.

The product exits Pattern Selection mode and returns to Sequence mode.

Changing the BPM

You can change the BPM (speed of the music).

1. Press the [BPM] button.



The BPM value appears on the main unit display.

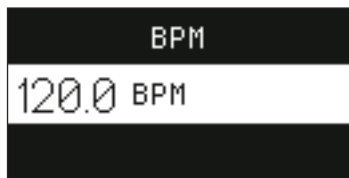

2. Press the [<] or [>] button.

Increasing the BPM value speeds up the tempo, and lowering it reduces the tempo.

Note

- Tap the **[BPM]** button repeatedly to set the BPM to the interval at which you tapped the button.

3. Press the [Enter] button.

The BPM is confirmed and the screen returns to the previous screen.

Note

- During setting of the BPM, if the **[BACK]** button is pressed or if no operation is performed for 5 seconds, setting of the BPM will be canceled.

Setting the keyboard scale

The product keyboard is arranged in a scale format like that of a keyboard instrument. You can set parameters such as the key, scale, and octave of the sounds you want to play with the keyboard.

Default keyboard scale settings

The leftmost key is set to C4 (middle C or note number 60 on a keyboard).



Setting the keyboard one octave higher/lower

Move the keyboard scale in octave units. (Octave shift)

1. While pressing the [↑] button, touch keyboard touch key [1] or [2].

To raise the octave, press touch key [2] on the keyboard. To lower the octave, press touch key [1] on the keyboard.

The main unit display shows the range of the currently set scale (touch keys [1] to [13]).



Frequently Used Basic Operations

For example, raising the unit one octave higher from the default settings changes the layout to the following.



Note

- The set sound range is saved for each track.

■ Set the keyboard one key higher/lower

You can move the keyboard scale up or down in units of one key (transposing). For example, this is useful when you want to include a scale three notes up on the keyboard.

1. While pressing the [↑] button, touch keyboard touch key [3] or [4].

To raise the key, press touch key [4] on the keyboard. To lower the key, press touch key [3] on the keyboard.

The main unit display shows the range of the currently set scale (touch keys [1] to [13] on the keyboard).



For example, raising the scale one key higher from the default settings changes the layout to the following.



Note

- The set sound range is saved for each track.

■ Setting the key

Set the key for the song you want to create.

1. While pressing the [↑] button, touch keyboard touch key [5] to display the key setting screen.

The main unit display shows the currently set key.

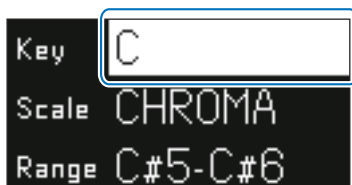

2. Press the [<] or [>] button to change the key.

3. Press the [Enter] button to confirm the key change.

Press the [Back] button to cancel the key change and return to the previous screen.

■ Changing the scale

Scales are combinations of notes that sound nice when used together. This product is equipped with a wide range of scales, from those used in general music production to other, more unusual varieties.

1. While pressing the [\uparrow] button, touch keyboard touch key [6] to display the scale setting screen.

The main unit display shows the currently set scale.



2. Press the [<] or [>] button to change the scale.
3. Press the [Enter] button to confirm the scale change.

Press the [Back] button to cancel the scale change and return to the previous screen.

For example, changing from the default settings to the key of “G” and the scale to “IONIAN” results in the following layout.



■ Setting the scale for a keyboard to which chords have been set

The scale can be set for a keyboard to which chords have been set or that is playing chords. There are two methods: moving the scale in units of ± 1 key or moving it in units of ± 12 keys.

1. Enter Chord Performance mode.
 - ▶ “Setting chords for Chord Performance mode” (p. 39)
 - ▶ “Assigning candidate voicing chords” (p. 39)
 - ▶ “Assigning candidate progression chords” (p. 41)
2. While pressing the [\uparrow] button, touch keyboard touch key [3] or [4].

To raise the scale, press touch key [4] on the keyboard. To lower the scale, press touch key [3] on the keyboard. The extent to which the scale is moved from the currently set scale appears on the main unit display with an indication such as **Transpose+1**.

Note

- The scale can be moved in units of ± 12 keys by pressing touch key [2] or [1] on the keyboard.
- If moving the scale is not possible, **Can't Transpose** will be displayed.

■ Setting the scale for touch keys to which chords have been set

The scale can be set for touch keys on a keyboard to which chords have been set or that is playing chords. There are two methods: moving the scale in units of ± 1 key or moving it in units of ± 12 keys.

1. Enter Chord Performance mode.
 - ▶ “Setting chords for Chord Performance mode” (p. 39)

Frequently Used Basic Operations

- ▶ “Assigning candidate voicing chords” (p. 39)
- ▶ “Assigning candidate progression chords” (p. 41)

2. While pressing the touch key you want to change, press the [<] or [>] button.

Example: When raised by 1 unit



The transposed chord is played and the chord components are displayed.

Note

- The scale can be moved in units of ± 12 keys by pressing the [\uparrow] button and the [<] or [>] button while pressing the touch key you want to change.
- If moving the scale is not possible, **Can't Transpose** will be displayed.

Entering notes in steps, one at a time

You can use the keyboard to enter one note at a time for the 16 step buttons.

There are two ways to do this.

- 1 Using the step buttons first
- 2 Using the keyboard first

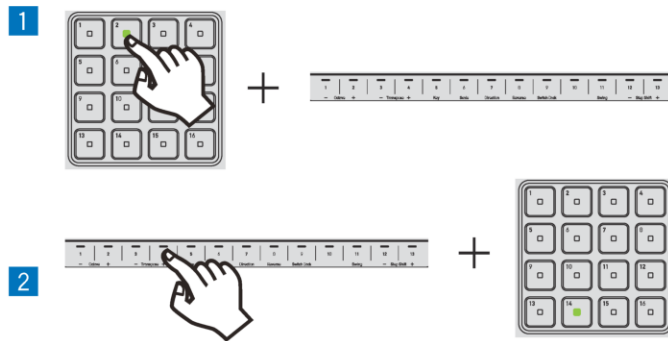

■ Using the step buttons first to enter notes

For this method, first press the step button you want to enter a note for.

1. Select a track and pattern to enter (to edit).
 - ▶ “Selecting a track” (p. 24)
 - ▶ “Selecting a pattern” (p. 25)
2. Press and hold the step button you want to enter a note for.
3. While pressing the step button, touch the keyboard and enter a note.

Use the keyboard to select a note to enter in a step. You can also enter multiple notes.

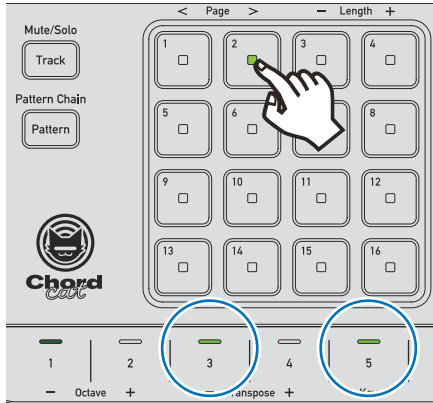

Step buttons light up in a bright green when a note is entered in a step.

While you're pressing a step button, the touch key on the keyboard corresponding to the note entered in the same step lights up in a bright green. Touching the touch key that is lit in a bright green deletes the note entered in that step.

Note

- You can enter a chord of up to six notes in a single step. If six notes have already been entered, it's not possible to add additional notes. If you want to add new notes, delete notes that have already been entered.

4. Repeat steps 2 and 3 to enter notes in other steps.

When there are multiple pages in a pattern, switch pages and edit them to suit your preferences.

- ▶ "Moving to the next/previous pattern page" (p. 47)

For details on copying and pasting steps and patterns, refer to the following.

- ▶ "Using the copy/paste function" (p. 49)

For details on deleting notes set for steps or deleting patterns, refer to the following.

- ▶ "Using the delete function" (p. 53)

Using the keyboard first

Decide which note to enter on the keyboard first, then enter the note in the step.

1. Select a track and pattern to enter (to edit).

- ▶ "Selecting a track" (p. 24)
- ▶ "Selecting a pattern" (p. 25)

2. While touching your chosen touch key on the keyboard, press the step button.

Frequently Used Basic Operations

The note of the touch key you're touching on the keyboard is entered in the step. You can also enter multiple notes.

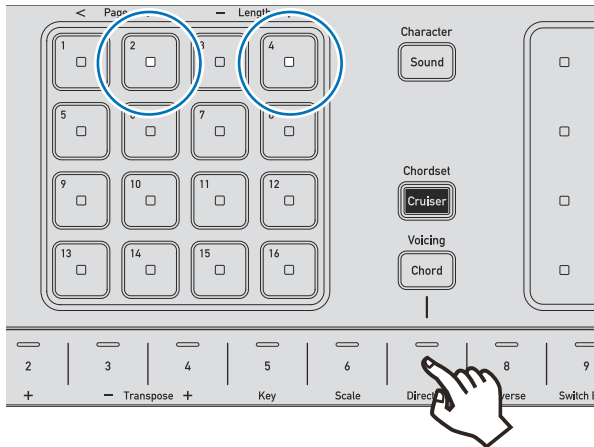

While you're touching a keyboard touch key, the step button with the same note entered lights up in white. Touching the step button that is lit in white deletes the note entered in that step.

Note

- You can enter a chord of up to six notes in a single step. If six notes have already been entered, it's not possible to add additional notes. If you want to add new notes, delete notes that have already been entered.

When you take your finger off the keyboard touch key, the step button for which the note was entered lights up in a bright green.

3. Repeat step 2 to enter notes in other steps.

When there are multiple pages in a pattern, switch pages and edit them to suit your preferences.

- ▶ “Moving to the next/previous pattern page” (p. 47)

For details on copying and pasting steps and patterns, refer to the following.

- ▶ “Using the copy/paste function” (p. 49)

For details on deleting notes set for steps or deleting patterns, refer to the following.

- ▶ “Using the delete function” (p. 53)

Entering a performance in real time

Use the keyboard and the XY pad to record your performance in real time.

Performance information that can be recorded

- Information on the notes and chords played on the keyboard
- XY pad performance information (manipulation of low-pass filters and amplifier envelope parameters)
 - ▶ “Adjusting the low-pass filter” (p. 55)
 - ▶ “Adjusting the amplifier envelope” (p. 56)

7. Select a track and pattern to record.

- ▶ “Selecting a track” (p. 24)
- ▶ “Selecting a pattern” (p. 25)

2. Press the [Sound] button, use the [<] or [>] button to select a sound category, then use the XY pad to select a sound preset.

Select the sound preset to be played by the track.

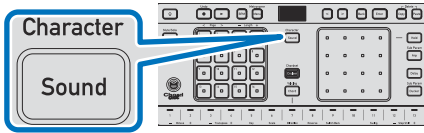

3. While pressing the [↑] button, press the [Menu] button to turn the metronome on.

The click sounds in time with the BPM.

For details on configuring the BPM, refer to the following.

- ▶ “Changing the BPM” (p. 26)

Note

- If it's difficult to capture your performance in real time, you can lower the tempo slightly to make things easier.

4. Press the [Rec] button.

5. Press the [Play] button to start sequencer playback.

When the [Rec] and [Play] buttons are brightly lit, the product is recording your performance.

Note

- You can set the product to start recording automatically when you operate the keyboard or XY pad. To do this, press the [Play] button while pressing the [Rec] button. The [Rec] button flashes and the product waits to start recording. Recording starts as soon as you operate the keyboard. (When the low-pass filter and amplifier envelope screen is displayed in Sound Setting mode, recording can also start when the XY pad is operated.)

6. Perform using the keyboard.

Your real-time performance on the keyboard is recorded.



Refer to the following if you want to set the keyboard scale.

- ▶ “Setting the keyboard scale” (p. 27)

7. Press the [Rec] button to stop recording.

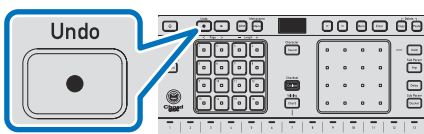

Check the recorded performance.

Creating Drum Patterns

8. Press the [Play] button to stop sequencer playback.

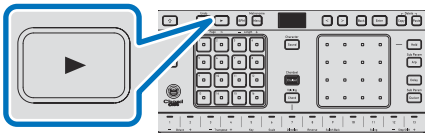

When there are multiple pages in a pattern, switch pages and edit them to suit your preferences.

▶ “Moving to the next/previous pattern page” (p. 47)

For details on deleting notes set for steps or deleting patterns, refer to the following.

▶ “Using the delete function” (p. 53)

Creating drum patterns

First, use the Drum Kit of the sound category to create a drum pattern. The following is an overview of the process for creating a drum pattern.

Select a track to use as a drum pattern



Select a drum kit



Enter a drum pattern



Create a new pattern

Main unit display



1 Currently selected track number

2 Currently selected pattern number

3 Currently selected sound preset

1. Press the [Track] button to enter Track Selection mode.

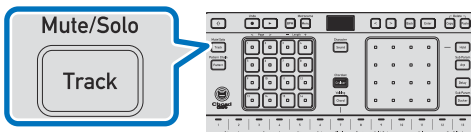

2. Press one of the step buttons marked [1] to [8] and select a track to record.

The button for the selected track lights up brightly.

3. Press the [Sound] button and select a sound preset to play in the track.

The sound preset selection screen appears on the main unit display.



1 Currently selected sound category

2 Currently selected sound preset

4. Press the [<] or [>] button to select a sound category.

Here, you will enter a drum pattern, so select **Drum Kit**.

5. Touch the XY pad to select a sound preset.

You can change the sound preset by touching the XY pad.

For example, select **Breakbeats Kit**.

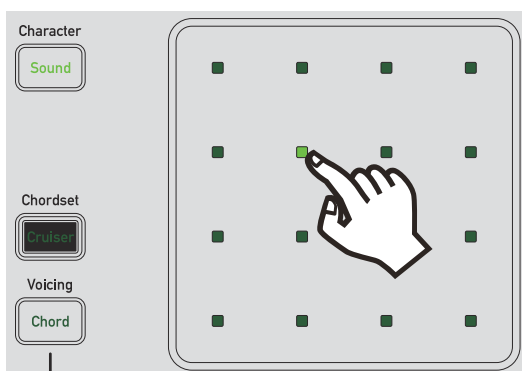

When you change the sound preset, a test note (C4, note number 60) plays so you can check what kind of feel the sound preset has.

The sound preset is assigned to the currently selected track. The sound preset also plays when you perform on the keyboard or the XY pad in real time.

6. Enter notes in steps one at a time, or enter a performance in real time.

- ▶ “Entering notes in steps, one at a time” (p. 30)
- ▶ “Entering a performance in real time” (p. 32)

7. Switch the pattern and create a different one.

When you want to create another pattern, switch the pattern and use the procedure described previously to create the next pattern.

- ▶ “Selecting a pattern” (p. 25)
- ▶ “Adding/removing pattern pages” (p. 46)

Note

- You can set the pattern you’ve created to play in any order you want. (Pattern chain function)
 - ▶ “Connecting two or more patterns” (p. 47)

Adjusting the volume of each instrument in the drum kit

When a drum kit has been assigned to a track, you can adjust the volume of each drum sound (for each corresponding note number). For example, you can adjust these settings if you don't want the snare drum to stand out so much.

1. Touch and hold the keyboard touch key for the drum sound you want to adjust.

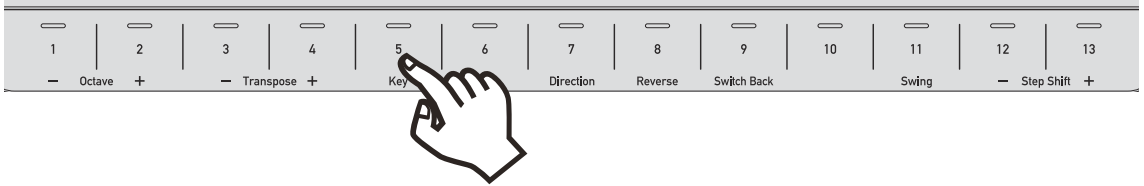

2. While touching the keyboard touch key, use the XY pad to adjust the volume.

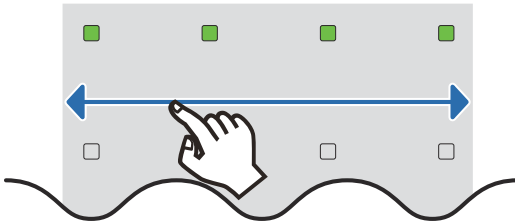

The top row of the XY pad lights up to indicate the approximate volume.

Touch the left or right side of the XY pad to adjust the volume. You can also use the [<] and [>] buttons to make adjustments.

The volume is shown numerically on the main unit display.

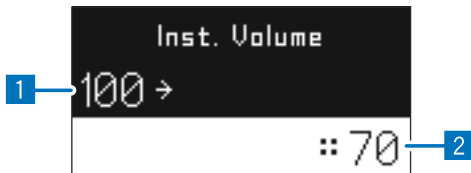

- 1 The previous volume setting.
- 2 The current volume setting.

Creating chord patterns

You can create chord patterns to provide instrumental accompaniment to your song. The following is an overview of the process for creating a chord pattern.

Select a track to use as a chord pattern



Select a sound preset



Enter a chord pattern



Create a new pattern

Main unit display

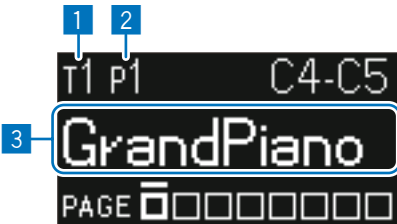

- 1** Currently selected track number
- 2** Currently selected pattern number
- 3** Currently selected sound preset

1. Press the [Track] button to enter Track Selection mode.

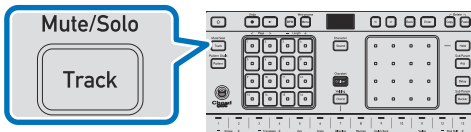

2. Press one of the step buttons marked [1] to [8], and select a track to record.

The button for the selected track lights up brightly.

3. Press the [Sound] button and select a sound preset to play in the track.

The sound preset selection screen appears on the main unit display.

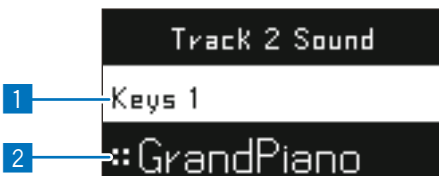

- 1** Currently selected sound category
- 2** Currently selected sound preset

4. Press the [<] or [>] button to select a sound category.

Here, you'll enter a chord pattern, so select **Keys 1**.

5. Touch the XY pad to select a sound preset.

You can change the sound preset by touching the XY pad.

For example, select **Legend EP**.

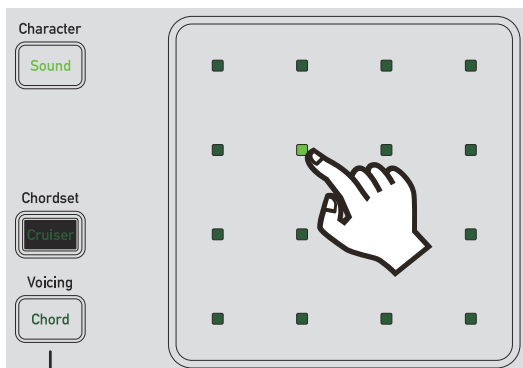

When you change the sound preset, a test note (C4, note number 60) plays so you can check what kind of feel the sound preset has.

The sound preset is assigned to the currently selected track. The sound preset also plays when you perform on the keyboard or the XY pad in real time.

6. Enter Chord Set Selection mode and select a chord set.

▶ “Setting chords for Chord Performance mode” (p. 39)

7. Assign candidate voicing chords and candidate progression chords.

▶ “Assigning candidate voicing chords” (p. 39)

▶ “Assigning candidate progression chords” (p. 41)

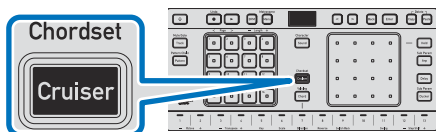

8. Enter notes in steps one at a time, or enter a performance in real time.

▶ “Entering notes in steps, one at a time” (p. 30)

▶ “Entering a performance in real time” (p. 32)

9. Switch the pattern and create a different one.

When you want to create another pattern, switch the pattern and use the procedure described previously to create the next pattern.

▶ “Selecting a pattern” (p. 25)

▶ “Adding/removing pattern pages” (p. 46)

Note

- You can set the pattern that you’ve created to play in any order you want. (Pattern chain function)
 - ▶ “Connecting two or more patterns” (p. 47)

Setting chords for Chord Performance mode

You can select the chord set you want from a selection of chord combinations for the keyboard provided based on the category of your song and other factors.

1. While pressing the [\uparrow] button, press the [Cruiser] button to enter Chord Set Selection mode.

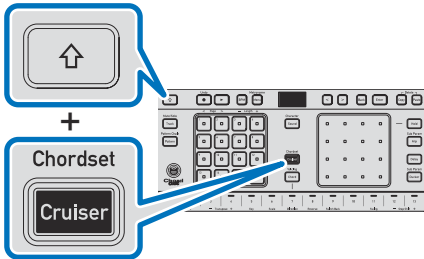

2. Press the [<] or [>] button to select a chord set.

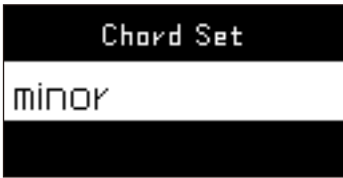

The currently selected chord set appears on the main unit display.

Note

- You can use the keyboard to play and check the chords in the selected chord set.

3. Press the [Enter] button to save the selected chord set.

Note

- Press the [Back] button, or press the [Cruiser] button while pressing the [\uparrow] button to exit Chord Set Selection mode.

Assigning candidate voicing chords

Based on a chord played on the keyboard, chords with similar characteristics but different sounds (candidate voicing chords) appear on the XY pad.

1. While pressing the [\uparrow] button, press the [Chord] button to enter Chord Voicing mode.

The [Chord] button lights up and the product enters Chord Voicing mode.

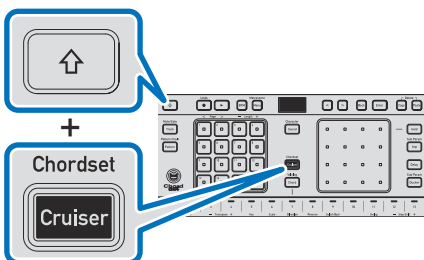

2. Touch the touch key of the chord for which you want to produce candidate voicing chords. The candidate voicing chords will then light up on the XY pad.

Candidate voicing chords for the chord played light up brightly on the XY pad. Dim lights on the XY pad indicate chords that contain notes not in the set key and scale.

Note

- For details on how to set the scale, refer to the following.
 - ▶ “Changing the scale” (p. 29)

3. Press the [Enter] button to select an item, then press the [<] and [>] buttons to select and set conditions to narrow down the candidate chords.

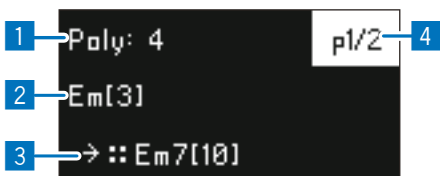

1 Number of notes

Set the number of chord notes to narrow down the chord candidates.

2 Current chord name

Displays the chord name. If the same chord name has different component notes, the number of notes displayed in [] after the chord name is different.

3

Displays the chord name of the candidate voicing chord. If the same chord name has different component notes, the number of notes displayed in [] after the chord name is different.

4 Current page/total pages

Displays the number of pages of candidates. A denominator of 2 or more indicates that there is a next page and more candidates can be displayed.

Note

- When “-” is selected for the number of notes, no conditions are set for the number of notes.

4. Touch a lit position on the XY pad to audition the sound of the next chord candidate.

Compare the chord selected using the touch key with the sound played by the XY pad to decide which candidate you’d like to use.

5. To set a candidate chord to the keyboard, while touching one of the positions on the XY pad, touch the keyboard touch key that you want to set the candidate chord to.

All of the lights on the keyboard flash until you touch a touch key. Once the selected chord is set to that touch key, only the set touch key remains flashing and the rest are lit up as usual.

Assigning candidate progression chords

Chord Cruiser mode makes it easy to create chord progressions that normally require advanced musical knowledge when composing.

1. Press the [Cruiser] button to enter Chord Cruiser mode.

The [Cruiser] button lights and the product enters Chord Cruiser mode.



2. Press the keyboard touch key of the chord for which you want to produce the next chord candidate and the candidate chords will light up on the XY pad.

Chord candidates suited to the played chord light up on the XY pad. Dim lights on the XY pad indicate chords that contain notes not in the set key and scale.

Note

- For details on how to set the scale, refer to the following.
 - ▶ “Changing the scale” (p. 29)

3. Press the [Enter] button to select an item, then press the [<] and [>] buttons to select and set conditions to narrow down the candidate chords.



1 Root note

Set the root note (the main note in a chord) to narrow down the chord candidates.

2 Number of notes

Set the number of chord notes to narrow down the chord candidates.

3 Current page/total pages

Displays the number of pages of candidates. A denominator of 2 or more indicates that there is a next page and more candidates can be displayed.

Note

- When “-” is selected for the root note and number of notes, no conditions are set for the root note and the number of notes.

4. Touch a lit position on the XY pad to audition the sound of the next chord candidate.

Compare the chord played using the keyboard with the chord played by the XY pad to decide which chord you'd like to use.

Creating Melody Patterns

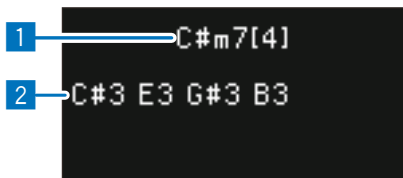

- 1 Displays the chord name. If the same chord name has different component notes, the number of notes displayed in [] after the chord name is different.
- 2 Displays the component notes of the chord.

5. To set a candidate chord to the keyboard, while touching one of the positions on the XY pad, touch the keyboard touch key that you want to set the candidate chord to.

All touch keys for which the chord can be set will start flashing. Once the selected chord is set to that touch key, only the set touch key remains flashing and the rest are lit up as usual.

Creating melody patterns

You can create a melody pattern that serves as the main melody to suit the chords and the rhythm of the drums. The following is an overview of the process for creating a melody pattern.

Select a track to use as a melody pattern



Select a sound preset



Enter a melody pattern



Create a new pattern

Main unit display

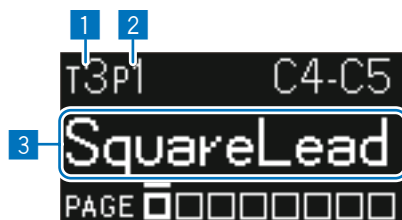

- 1 Currently selected track number
- 2 Currently selected pattern number
- 3 Currently selected sound preset

1. Press the [Track] button to enter Track Selection mode.

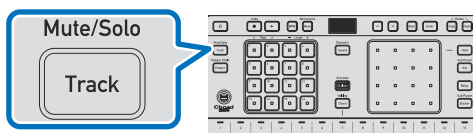

2. Press one of the step buttons marked [1] to [8], and select a track to record.

The button for the selected track lights up brightly.

3. Press the [Sound] button and select a sound preset to play in the track.

The sound preset selection screen appears on the main unit display.

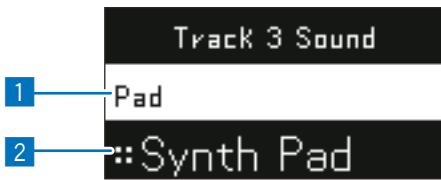

1 Currently selected sound category

2 Currently selected sound preset

4. Press the [<] or [>] button to select a sound category.

Here, you'll enter a melody pattern, so select **Synth lead**.

5. Touch the XY pad to select a sound preset.

You can change the sound preset by touching the XY pad.

For example, select **Blowing**.

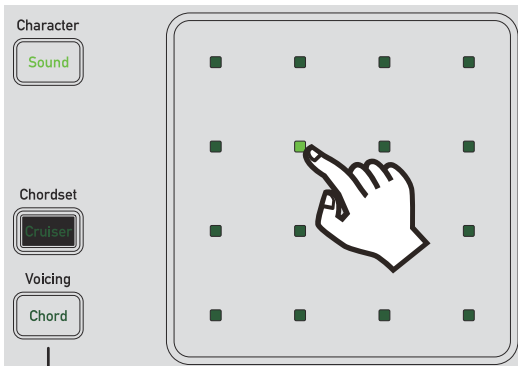

When you change the sound preset, a test note (C4, note number 60) plays so you can check what kind of feel the sound preset has.

The sound preset is assigned to the currently selected track. The sound preset also plays when you perform on the keyboard or the XY pad in real time.

6. Enter notes in steps one at a time, or enter a performance in real time.

- ▶ “Entering notes in steps, one at a time” (p. 30)
- ▶ “Entering a performance in real time” (p. 32)

7. Switch the pattern and create a different one.

When you want to create another pattern, switch the pattern and use the procedure described previously to create the next pattern.

- ▶ “Selecting a pattern” (p. 25)
- ▶ “Adding/removing pattern pages” (p. 46)

Note

- You can set the pattern that you've created to play in any order you want. (Pattern chain function)
 - ▶ “Connecting two or more patterns” (p. 47)

Turning triggers on/off

The notes entered in a step can be turned on and off instantly.

Step button state



On (played)



Off (not played)

When multiple tones (different scales) are set to the same step, they're all turned on/off together.

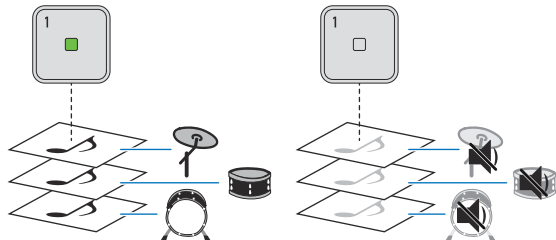

Note

- The step buttons are set to note number 60 (C4) with the sound off by default.

1. Select a track and pattern to edit.

- ▶ “Selecting a track” (p. 24)
- ▶ “Selecting a pattern” (p. 25)

2. Press a step button that is lit in a dim green to turn on the sound for that step.

The step button you pressed will light up in a bright green, and the sound for that step will be turned on.

3. Press a step button that is lit up in a bright green to turn off the sound for that step.

The step button you pressed will light in a dim green, and the sound for that step will be turned off (this step will serve as a rest).

4. Repeat steps 1 through 3 to turn each step on or off.

When there are multiple pages in a pattern, switch pages and edit them to suit your preferences.

- ▶ “Moving to the next/previous pattern page” (p. 47)

Previewing the notes entered to the step buttons

You can preview what notes are currently set for the step buttons.

1. Press and hold a step button.

The note set for the step button you pressed will play.

Note

- You can change how and if the note plays when you press and hold a step button.
 - ▶ “Setting the step preview method” (p. 84)

Making detailed sound adjustments

You can finely adjust the pitch, gate length, and velocity of the notes that you've entered to the step buttons.

Adjusting individual steps

1. Select a track and pattern to edit.

- ▶ “Selecting a track” (p. 24)
- ▶ “Selecting a pattern” (p. 25)

2. Press and hold the step button you want to edit.

While you're pressing a step button, the touch key on the keyboard corresponding to the note in that pattern lights up.

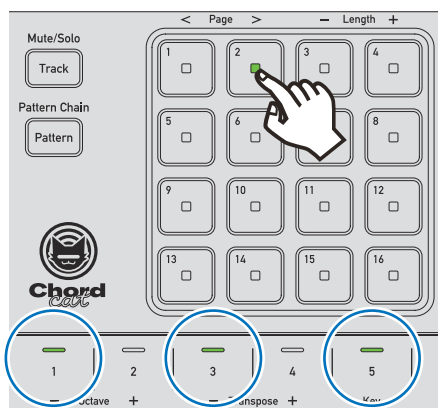

Note

- If there's a note whose pitch you don't want to change, touch the key for that note once to turn it off, then touch the key again to turn it on after adjusting the other notes.

3. While pressing the step button, touch the left or right side of the XY pad to change the values.

Touch the left side of the XY pad to lower a value and touch the right side to increase it.

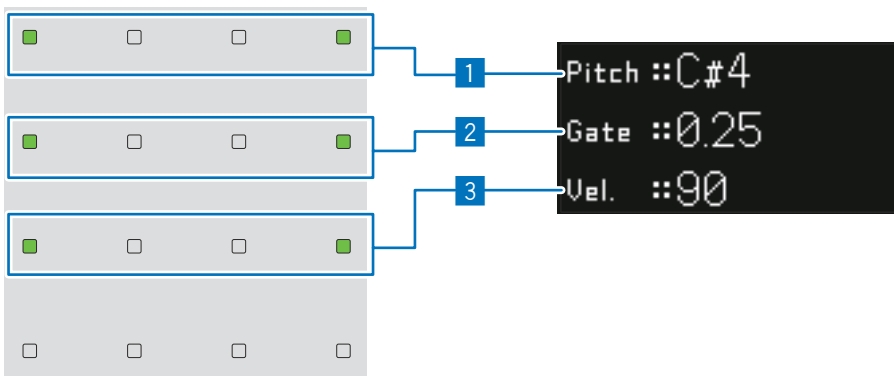

- 1 Adjusts the pitch. The display shows the sound range.

Editing Patterns

- 2 Adjusts the gate length (length of the sound). The display shows the length of the sound. The unit is in steps.

Note

- While pressing the step button, press the [↑] button and touch the part that is dimly lit to return the set gate length to the default value.

- 3 Adjusts the velocity (strength of the sound). The display shows the strength of the sound. The larger the value, the louder it will play.

Note

- While pressing the step button, press the [↑] button and touch the part that is dimly lit to return the set velocity to the default value.

Editing a whole pattern

You can finely adjust the pitch, gate length, and velocity of the notes that you've entered to all the step buttons in a pattern, all at once.

1. Select a track to edit.

- ▶ "Selecting a track" (p. 24)

2. Press the [Pattern] button to enter Pattern Selection mode.

3. Press and hold the step button corresponding to the pattern you want to edit.

While you're pressing a step button, the touch key on the keyboard corresponding to the note in that pattern lights up.

4. While pressing the step button, touch the left or right side of the XY pad to change the values.

Refer to the following for parameters that can be changed.

- ▶ "Adjusting individual steps" (p. 45)

Adding/removing pattern pages

If you want to make a pattern longer, you can add more pages. Patterns can be up to eight pages (128 steps) long. You can also remove pages that you've added.

1. Enter Pattern Editing mode and select the pattern you want to edit.

- ▶ "Selecting a pattern" (p. 25)

2. While pressing the [↑] button, press step button [4].

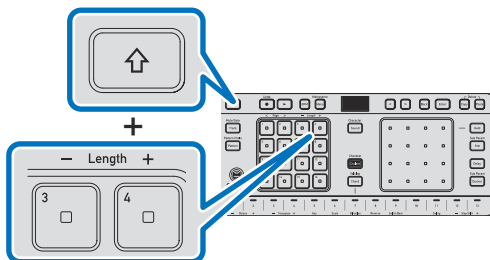

A page is added and the main unit display shows this.

You can also remove pages that you've added. If you want to make the pattern shorter, press step button [3].

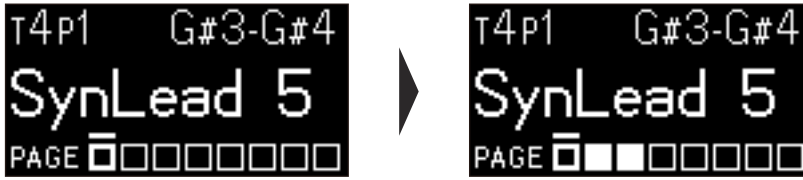

(Example: When you've created a total of three pages)

Moving to the next/previous pattern page

When you have multiple pages in a pattern, you can select one and edit things on it.

1. Enter Pattern Editing mode and select the pattern you want to edit.

▶ “Selecting a pattern” (p. 25)

2. While pressing the [↑] button, press step button [1] or [2].

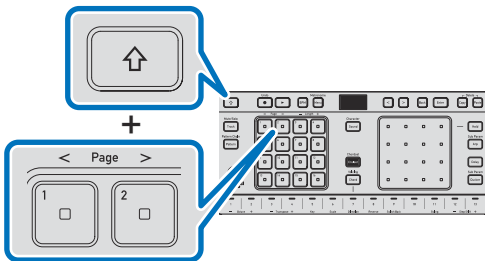

The main unit display moves to the previous or next page.

Main unit display

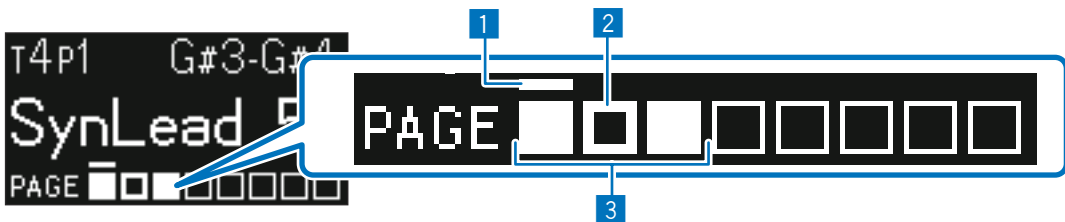

1 Page currently playing (moves to show the relevant page when the sequencer is playing.)

2 Page currently being edited with the step buttons

3 All pages

Squares with thin lines indicate that there are no pages in these spaces.

Connecting two or more patterns

You can make the patterns that you've created play in any order.

1. Select the track containing the pattern you want to connect.

▶ “Selecting a track” (p. 24)

Editing Patterns

2. While pressing the [↑] button, press the [Pattern] button to enter Pattern Chain Setting mode.

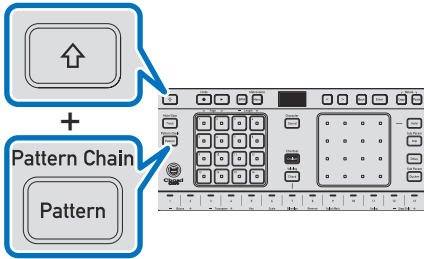

3. Press the step buttons in the order you want your patterns to play.

The pattern numbers appear on the main unit display in the order you pressed them.

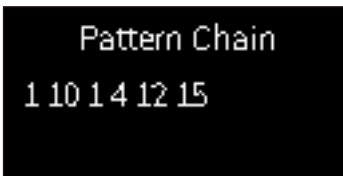

In this example, the patterns are played in the order below.

Pattern 1 → Pattern 10 → Pattern 1 → Pattern 4 → Pattern 12 → Pattern 15 → Returns to the first Pattern 1

Flashing step buttons indicate patterns included in the performance order. The pattern currently playing will flash brightly, while all other patterns will flash dimly. Also, patterns waiting for playback will flash white (they will light up in white when sequencer playback is stopped).

Note

- Press the [Back] button to cancel the order set at the end of the pattern chain.

4. While pressing the [↑] button, press the [Pattern] button to exit Pattern Chain Setting mode.

The product returns to Sequence mode and sequencer playback continues in the set pattern order.

Stopping pattern chain playback

1. Press the [Copy] and [Paste] buttons simultaneously to enter Delete mode.

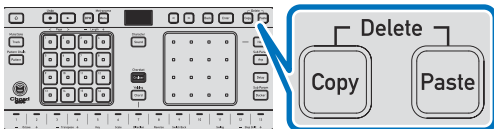

2. Press one of the step buttons.

The pattern chain setting is canceled and sequencer playback in the set pattern order stops.

Using the copy/paste function

You can copy and paste items to efficiently create repeated or rearranged sections.

The following items can be copied.

- Tracks
- Patterns
- Notes recorded to the step buttons
- Keyboard chords

Copying and pasting tracks

1. Press the [Track] button to enter Track Selection mode.

Continue with the following steps while in Track Selection mode.

2. While pressing the [Copy] button, press one of the step buttons marked [1] to [8] where the track to be copied is recorded.

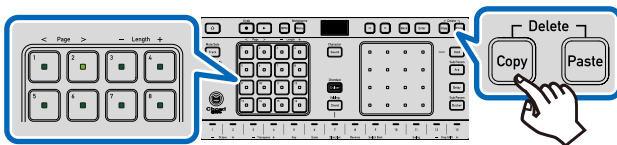

While the [**Copy**] button is pressed, the pressed step button lights up in white to indicate that the contents of that button will be copied. Release the [**Copy**] button to copy the contents.

3. While pressing the [Paste] button, press one of the step buttons marked [1] to [8] to choose where the contents will be pasted to.

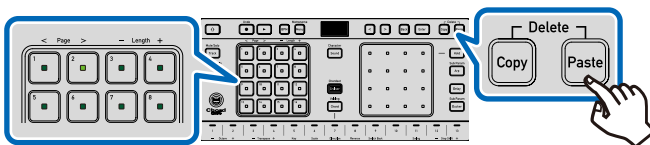

While the [**Paste**] button is pressed, the pressed step button lights up in white to indicate where the contents will be pasted to. Release the [**Paste**] button to paste the contents.

4. Press the [Track] button to exit Track Selection mode.

Check the contents of the pasted track.

Copying and pasting patterns

Note

- You can also copy and paste patterns across tracks.

1. Switch to the page of the pattern with the contents you want to copy.

- ▶ “Selecting a track” (p. 24)
- ▶ “Selecting a pattern” (p. 25)

Creating Patterns Efficiently

▶ “Moving to the next/previous pattern page” (p. 47)

2. Press the [Pattern] button to enter Pattern Selection mode.

Continue with the following steps while in Pattern Selection mode.

3. While pressing the [Copy] button, press one of the step buttons marked [1] to [16] where the track to be copied is recorded.

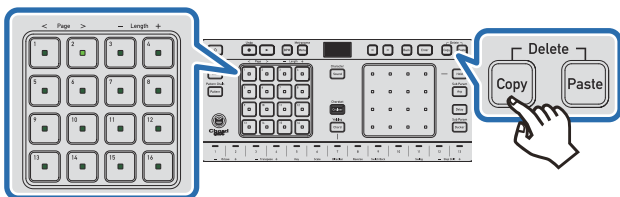

While the [Copy] button is pressed, the pressed step button lights up in white to indicate that the contents of that button will be copied. Release the [Copy] button to copy the contents.

4. Switch to the pattern you want to paste to.

5. While pressing the [Paste] button, press one of the step buttons marked [1] to [16] to choose where the contents will be pasted to.

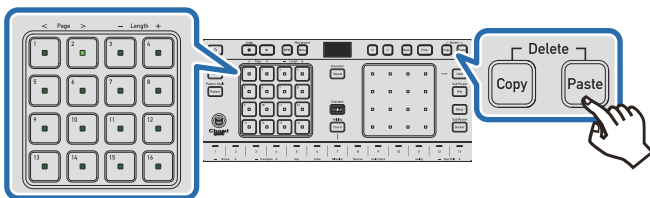

While the [Paste] button is pressed, the pressed step button lights up in white to indicate where the contents will be pasted to. Release the [Paste] button to paste the contents.

6. Press the [Pattern] button to exit Pattern Selection mode.

Check the contents of the pasted pattern.

Copying and pasting notes recorded to the step buttons

To copy and paste the contents of a step button, carry out the procedure in Sequence mode.

Note

- You can also copy and paste steps across tracks and patterns.

■ Copying and pasting the contents of one step button

1. Switch to the page of the pattern with the contents you want to copy.

- ▶ “Selecting a track” (p. 24)
- ▶ “Selecting a pattern” (p. 25)
- ▶ “Moving to the next/previous pattern page” (p. 47)

2. While pressing the [Copy] button, press one of the step buttons marked [1] to [16] where the contents to be copied are recorded.

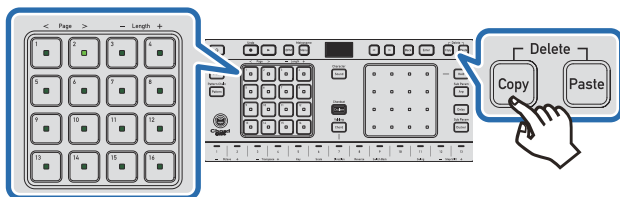

While the [Copy] button is pressed, the pressed step button lights up in white to indicate that the contents of that button will be copied. Release the [Copy] button to copy the contents.

3. Switch to the page of the pattern that contains the step you want to paste to.
4. While pressing the [Paste] button, press one of the step buttons marked [1] to [16] to choose where the contents will be pasted to.

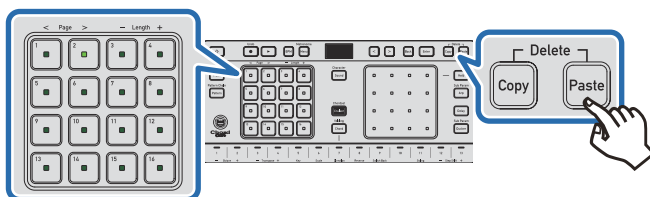

While the [Paste] button is pressed, the pressed step button lights up in white to indicate where the contents will be pasted to. Release the [Paste] button to paste the contents.

■ Copying and pasting the contents of multiple step buttons

You can copy and paste the contents of multiple step buttons at the same time.

The following is an example of copying step buttons [2] through [8] and pasting their contents to step buttons [10] through [16].

1. Switch to the page of the pattern with the contents you want to copy.

- ▶ “Selecting a track” (p. 24)
- ▶ “Selecting a pattern” (p. 25)
- ▶ “Moving to the next/previous pattern page” (p. 47)

2. Press and hold the [Copy] button.

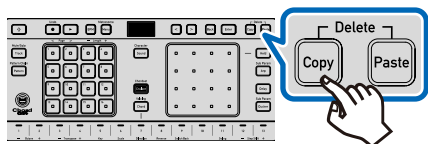

3. While pressing step button [2], press step button [8].

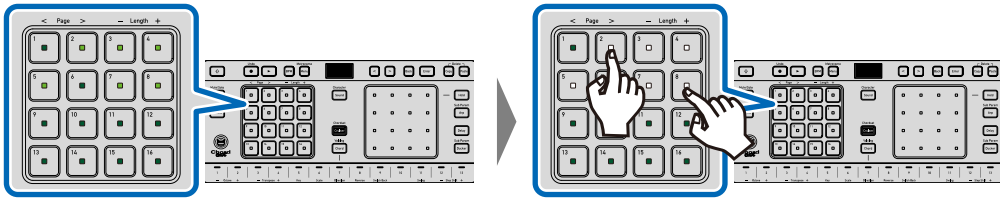

While the [Copy] button is pressed, all the step buttons in the pressed range light up in white to indicate that their contents will be copied. Release the [Copy] button to copy the contents.

4. Switch to the page of the pattern that contains the steps you want to paste to.

5. While pressing the [Paste] button, press step button [10] to choose that as the first in the range of steps the contents will be pasted to.

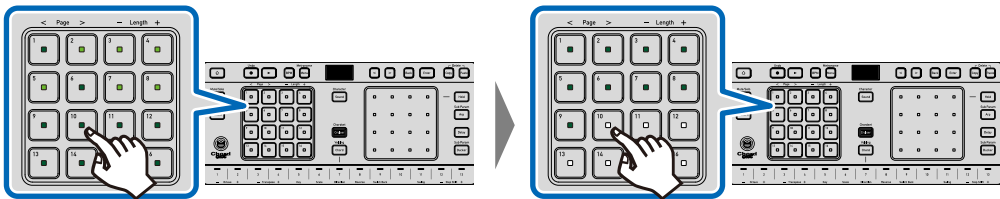

While the [Paste] button is pressed, all the step buttons to which the contents will be pasted will light up in white, starting with the pressed step button. (In this example, step buttons [10] through [16] light up.) Release the [Paste] button to paste the contents.

Note

- When copying and pasting the contents of multiple step buttons, the range to which contents can be pasted is limited to the pages that already exist. (Contents can't be pasted beyond the end of the last page. This means up to step button [16].) If you want to paste across pages, be sure to create the necessary additional pages in advance.

Copying and pasting chords

You can copy and paste chords while in Chord Performance mode.

1. Enter Chord Performance mode.

- ▶ “Setting chords for Chord Performance mode” (p. 39)
- ▶ “Assigning candidate voicing chords” (p. 39)
- ▶ “Assigning candidate progression chords” (p. 41)

2. While pressing the [Copy] button, touch one of the keyboard touch keys [1] to [13] with the contents you want to copy.

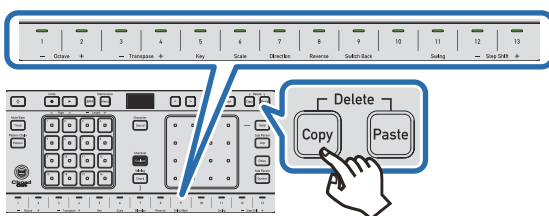

The touched touch key flashes to indicate that its contents will be copied.

3. Release the [Copy] button.

The contents are copied.

4. While pressing the [Paste] button, touch one of the keyboard touch keys [1] to [13] to choose where the contents will be pasted to.

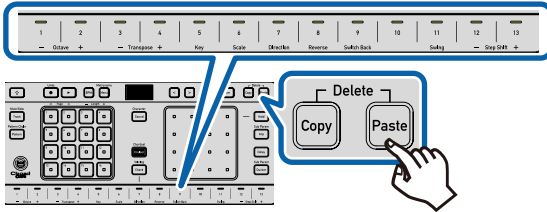

The touched touch key flashes to indicate where the contents will be pasted to.

Using the delete function

You can delete items and settings.

The following can be deleted.

- Step button settings
- Patterns
- Chords assigned to the keyboard
- XY pad performance information (Manipulation of low-pass filters and amplifier envelope parameters)
 - ▶ “Adjusting the low-pass filter” (p. 55)
 - ▶ “Adjusting the amplifier envelope” (p. 56)

Deleting step button settings

1. Switch to the page of the pattern with the step you want to delete.

- ▶ “Moving to the next/previous pattern page” (p. 47)

2. While pressing the [Copy] and [Paste] buttons, press the step button of the step you want to delete.

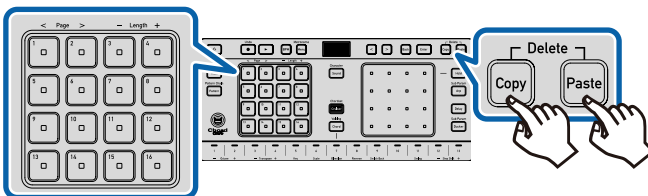

The pressed step button returns to its default setting and the trigger is also turned off.

Deleting patterns

You can delete a pattern you've set.

1. Press the [Pattern] button to enter Pattern Selection mode.

Continue with the following steps while in Pattern Selection mode.

2. While pressing the [Copy] and [Paste] buttons, press one of the step buttons with a pattern recorded.

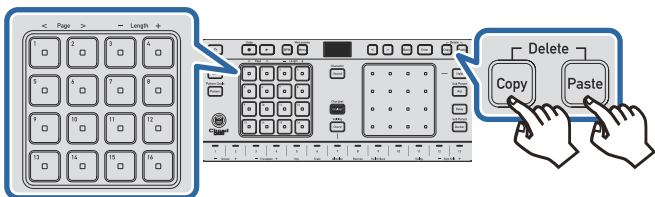

The pattern is deleted.

Deleting chords assigned to the keyboard

You can delete chords set on the keyboard.

1. Enter Chord Performance mode.

- ▶ “Setting chords for Chord Performance mode” (p. 39)
- ▶ “Assigning candidate voicing chords” (p. 39)
- ▶ “Assigning candidate progression chords” (p. 41)

2. While pressing the [Copy] and [Paste] buttons, touch one of the touch keys on the keyboard.

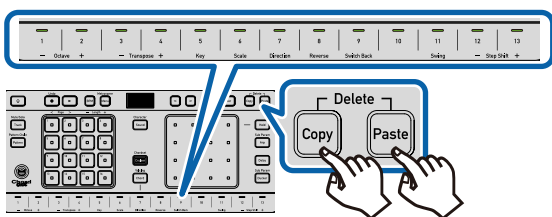

The chord set to that keyboard touch key is deleted.

Using the undo function

You can undo the following operations immediately after performing them.

- Recordings of real-time performances and sound character operations (low-pass filter, amplifier envelope)
- Paste operations
- Delete operations

Undo isn't available after the following operations.

- Changing modes
- Pattern editing

- Track editing
- Project creation and opening

1. While pressing the [↑] button, press the [Rec] button.

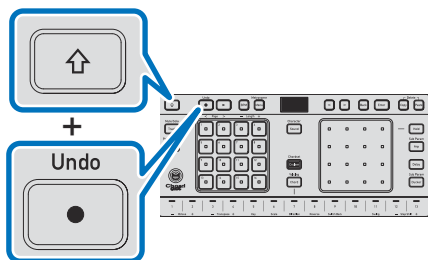

Undo appears on the main unit display when an operation is successfully undone.

Note

- If the operation couldn't be undone, **Can't Undo** appears on the main unit display.

Adjusting the low-pass filter

You can use the low-pass filter to cut high frequencies.

1. Press the [Track] button to enter Track Selection mode and select the track you want to apply the effect to.

2. While pressing the [↑] button, press the [Sound] button to enter Sound Character Setting mode.

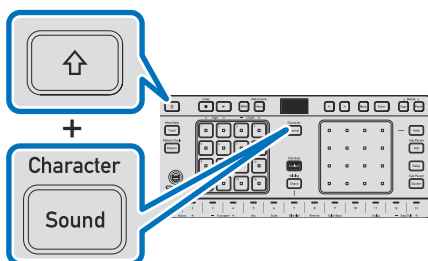

3. Press the [<] button to select **Lowpass Filter**.

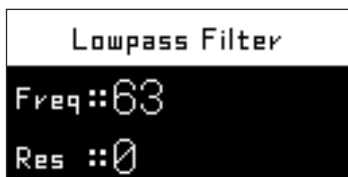

4. Touch the XY pad to adjust the values.

Touch the left or right side of the XY pad to adjust the cut-off frequency, and touch the top or bottom to adjust the resonance.

- **Freq** (Cut-off frequency)
Frequencies higher than the set frequency are cut off.

Adjusting the Character of Sound Presets

- **Res** (Resonance)
Frequencies near the cut-off frequency are accentuated.

Adjusting the amplifier envelope

You can use the amplifier envelope to adjust attack and release.

1. Press the [Track] button to enter Track Selection mode and select the track you want to apply the effect to.
2. While pressing the [↑] button, press the [Sound] button to enter Sound Character Setting mode.

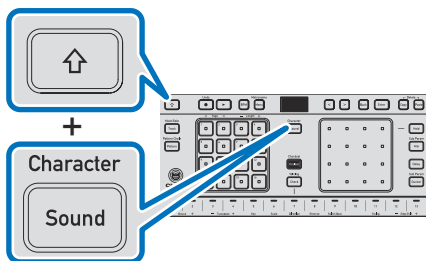

3. Press the [<] or [>] button to select **Amp Envelope**.

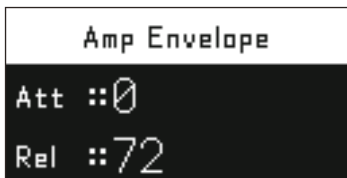

4. Touch the XY pad to adjust the values.

Touch the left or right side of the XY pad to adjust the attack, and touch the top or bottom to adjust the release.

- **Att** (Attack)
Adjust how long it takes for a sound to reach its maximum volume after the sound is played in a sequence or by a sound production operation.
Decreasing the value makes the rise of the output sound sharper and gives it a stronger attack.
- **Rel** (Release)
Adjust how long it takes for a sound's volume to reach zero after the sound is played in a sequence or by a sound production operation.
Increasing the value results in the output sound trailing longer.

Setting how the sound is produced (mono/poly)

You can set the sound output to monophonic or polyphonic. With monophonic (mono) output, only the last note triggered is played. With polyphonic (poly) output, two or more notes can be played simultaneously, e.g., to make a chord.

1. Press the [Track] button to enter Track Selection mode and select the track you want to apply the settings to.
2. While pressing the [↑] button, press the [Sound] button to enter Sound Character Setting mode.

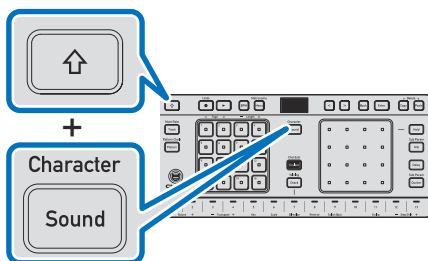

3. Press the [<] or [>] button to select **Mono/Poly**.



4. Touch the XY pad to set how the sound is produced.

Touch the left or right side of the XY pad to select monophonic or polyphonic.

- **Mono** (Monophonic)
Only one note is played at each step. Mainly used to create bass and lead sounds.
- **Poly** (Polyphonic)
Two or more notes, such as chords, can be played at each step. Use the poly setting when you want to create thicker sounds, such as chords.

Note

- When the **Drum Kit** sound category is selected, the setting is fixed to **Poly**.

Setting portamento time

You can adjust the portamento time to smoothly connect different pitches.

1. Press the [Track] button to enter Track Selection mode and select the track you want to apply the effect to.
2. While pressing the [↑] button, press the [Sound] button to enter Sound Character Setting mode.

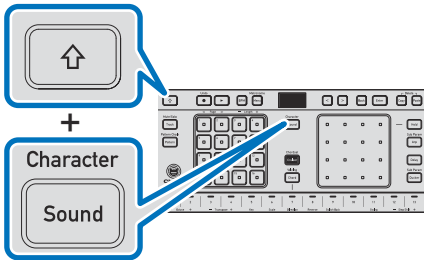

3. Press the [>] button to select **Portamento Time**.

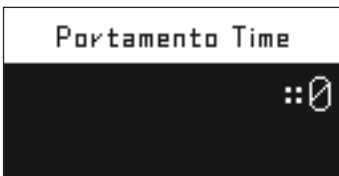

4. Touch the XY pad to adjust the values.

Touch the left or right side of the XY pad to adjust the portamento time. Increasing the value results in a smoother pitch transition.

Note

- If the sound category of the selected sound preset is “Drum Kit”, the portamento time is fixed to 0.

Adjusting the volume and left/right stereo localization of a track

Adjusting the volume

You can adjust the volume of each track separately.

1. Press the [Track] button to enter Track Selection mode.
2. Press one of the step buttons marked [1] to [8] to select the track whose volume you want to adjust.

- While pressing step button [13], touch the XY pad to adjust the volume.

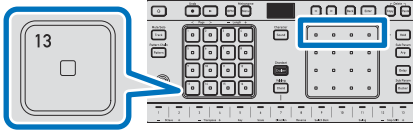

You can only adjust the volume while pressing step button [13].

Touch the left or right side of the XY pad to adjust the volume. You can also use the [<] and [>] buttons to make adjustments.

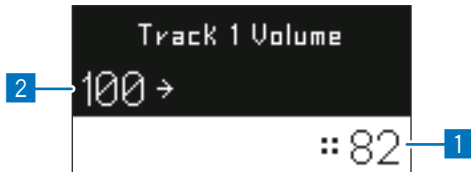

- The current volume setting.
- The volume setting before volume adjustment.

Note

- While pressing the [↑] button, touch the XY pad to return to the default setting (100).

Adjusting the pan

You can adjust the left/right output balance of each track separately.

- Press the [Track] button to enter Track Selection mode.
- Press one of the step buttons marked [1] to [8] to select the track whose left/right output balance you want to adjust.
- While pressing step button [14], touch the XY pad to adjust the left/right output balance.

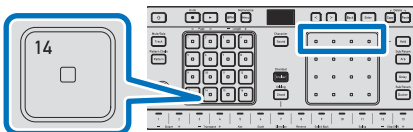

You can only adjust the left/right output balance while pressing step button [14].

Touch the left or right side of the XY pad to adjust the left/right output balance. You can also use the [<] and [>] buttons to make adjustments.

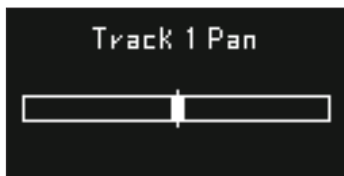

Note

- While pressing the [↑] button, touch the XY pad to return to the default setting (center position).

Setting the level of effects applied to each track

Applying reverb

Use reverb when you want to add a sense of space and expansiveness to the sounds of a track.

1. Press the [Track] button to enter Track Selection mode.
2. Press one of the step buttons marked [1] to [8] to select the track whose reverb you want to adjust.
3. While pressing step button [15], touch the XY pad to adjust the reverb.

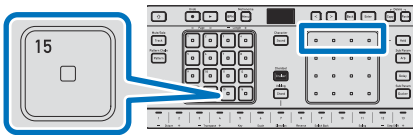

You can only adjust the reverb while pressing step button [15].

Touch the left or right side of the XY pad to adjust the reverb. You can also use the [<] and [>] buttons to make adjustments.



1 The currently set value. The higher the value, the greater the reverb effect.

2 The value before the change.

Note

- Refer to the following if you want to adjust advanced settings.
 - ▶ “Finely adjusting reverb” (p. 82)

Applying chorus

Chorus gives sounds a wavering effect.

1. Press the [Track] button to enter Track Selection mode.
2. Press one of the step buttons marked [1] to [8] to select the track whose chorus you want to adjust.
3. While pressing step button [16], touch the XY pad to adjust the chorus.

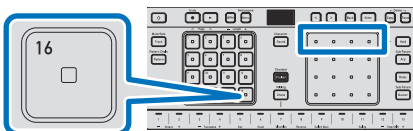

You can only adjust the chorus while pressing step button [16].

Touch the left or right side of the XY pad to adjust the chorus. You can also use the [<] and [>] buttons to make adjustments.

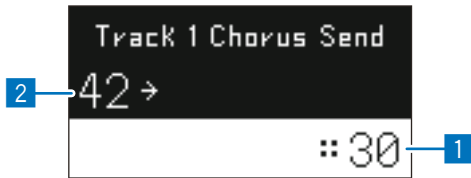

1 The currently set value. The higher the value, the greater the chorus effect.

2 The value before the change.

Note

- Refer to the following if you want to adjust advanced settings.
 - ▶ “Finely adjusting chorus” (p. 83)

Switching between mute and solo on each track

Use mute and solo to mute or solo a specific track during music production or a live performance.

Mute: Mutes a specific track.

Solo: Plays a specific track while muting all other tracks.

- 1. While pressing the [\uparrow] button, press the [Track] button to enter Mute/Solo Setting mode.**
- 2. Press any of the step buttons marked [1] to [8] to select the tracks you want to mute.**
Buttons set to mute light in a dim green. The buttons of tracks that are not muted light up in a bright green.
- 3. While pressing the [\uparrow] button, press one of the step buttons marked [1] to [8] to select the track you want to solo.**

The button set to solo will light up in white. Tracks other than the one set to solo are muted. While pressing the [\uparrow] button once again, press the button of the track set to solo to return the buttons to the state they were in prior to setting solo. You can also set a track set to mute to solo.

Changing the direction of sequence progression to create new phrases

You can play different patterns from a single pattern by changing the direction of sequence progression.

Setting the sequence progression direction (running direction)

1. While pressing the [↑] button, touch keyboard touch key [7] to display the running direction type setting screen.
2. Press the [<] or [>] button to select the direction of sequence progression.



Right

The default sequencer playback order. Plays the step buttons from [1] through [16] in order.

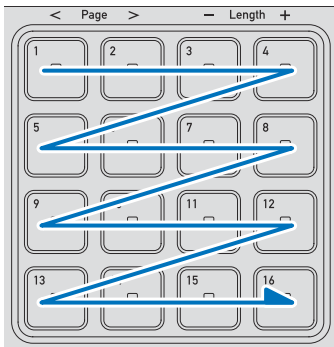

Clockwise

Plays the sequencer clockwise.

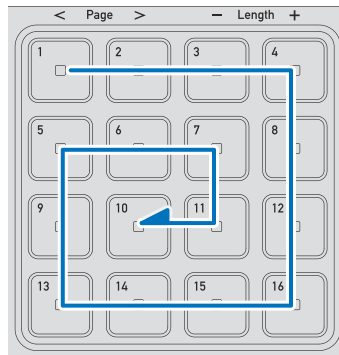

Down

Plays the sequencer from top to bottom.

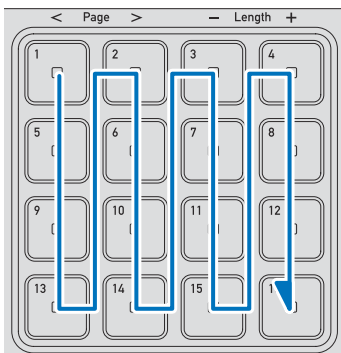

Counter Clockwise

Plays the sequencer counterclockwise.

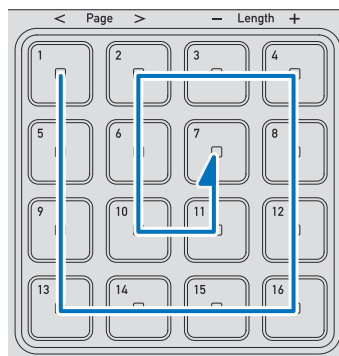

Reversing the playback order of the steps

You can reverse the playback order while keeping the currently set sequencer playback direction.

Note

- If there are multiple pages, the pattern is played from the end of the pattern on the last page to the beginning of the start page. When playback of the first step of the pattern on the start page is completed, playback starts again from the end of the pattern on the last page.

1. While pressing the [↑] button, press keyboard touch key [8] to enter Running Direction mode.

2. Press the [<] or [>] button to select **Reverse On**.



Example: If set to **Right**, the sequencer playback order will be as follows.

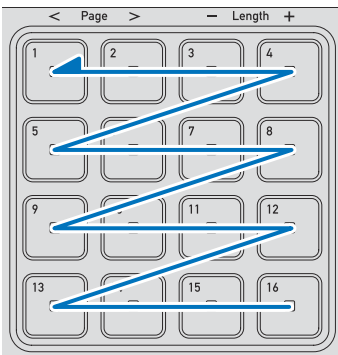

Reversing the direction and replaying the steps from the end

You can set playback to run from the first step to the last step in the pattern with the currently set playback direction, and then reverse the direction and run from the last step to the first step.

Note

- If there are multiple pages, playback starts from the beginning of the start page, and when playback of the end of the pattern on the last page is completed, the playback direction reverses and runs to the beginning of the pattern on the start page.

1. While pressing the [↑] button, press keyboard touch key [9] to enter Running Direction mode.

Arranging Patterns

2. Press the [<] or [>] button to select **SwitchBack On**.



Example: If set to Right, the playback order will be as follows.

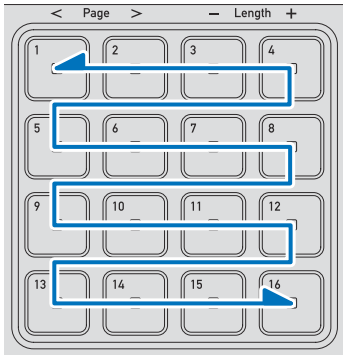

Shifting steps to create new phrases

The sounds of all the steps of your pattern can be shifted forward or backward. You can create new patterns without making major changes to the order.

Example: Positions that each step moves to when shifted backward one step

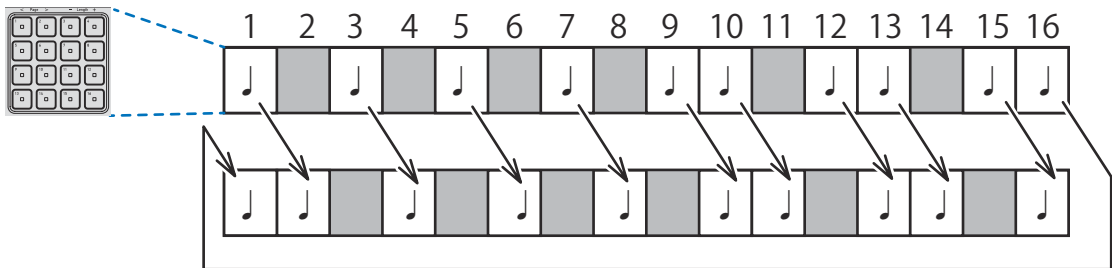

If there are multiple pages, the step at the end of the last page becomes the first step on the start page if the steps are shifted one step backward, and the first step on the start page becomes the step at the end of the last page if the steps are shifted one step forward.

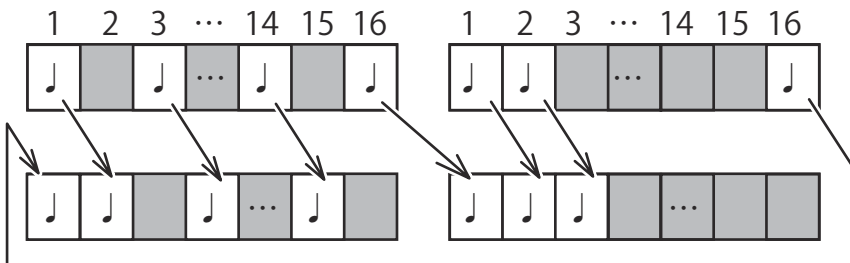

7. While pressing the [↑] button, touch keyboard touch key [12] or [13].

Touch keyboard touch key [12] to shift one step forward. Touch keyboard touch key [13] to shift one step backward.

The lighting state of each step button changes.

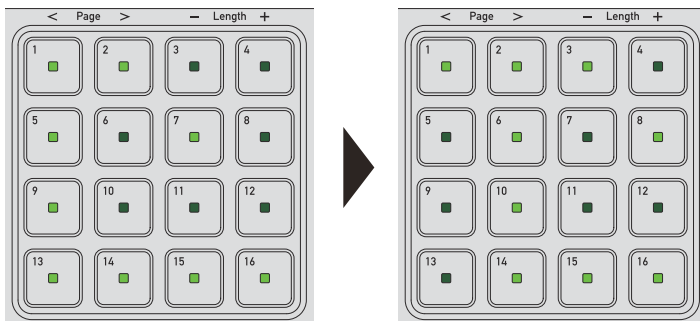

Note

- If the direction of sequence progression has been changed, the steps shift forward or backward according to the new progression direction.
 - ▶ “Selecting a pattern” (p. 25)

Using swing to create a groove

By fluctuating the timing of step playback, the intervals between notes change, creating a new pattern with a groove.

Example: Illustration of changes in play timings when swing is set to 50%

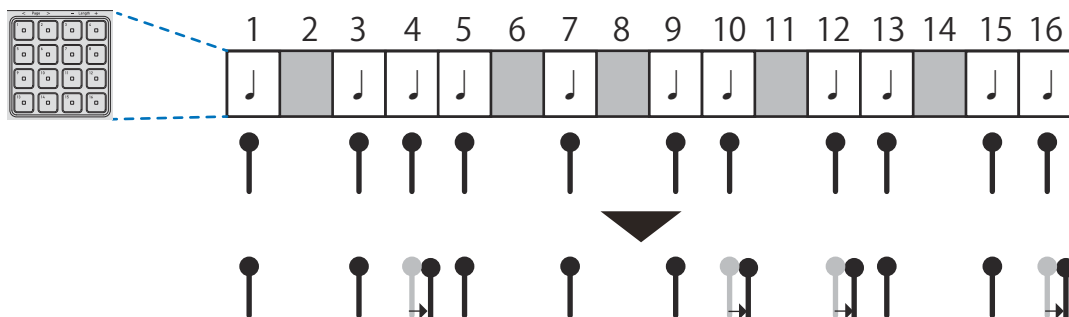

1. While pressing the [↑] button, touch keyboard touch key [11] to enter Swing Setting mode.

2. Press the [<] or [>] button to set the swing value.

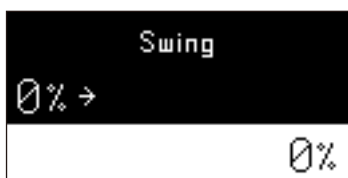

Using effects to add arrangements to phrases

Three types of effects are available – arpeggiator, delay, and ducker – and you can control these effects with the XY pad.

These effects can be applied to sounds played in real time or to sounds you've already input.

Using the arpeggiator

The arpeggiator creates an arpeggio effect that plays in time with the BPM.

What is an arpeggio?

Chords are basically multiple notes played simultaneously, but when they are played in sequence instead, it's called an "arpeggio."

Specifically, in the example chord below composed of C, E, G, and high C, even if you touch these four notes simultaneously, the arpeggiator function will play them one at a time in order and in time with the BPM.



1. Select a track.

▶ "Selecting a track" (p. 24)

2. Select a pattern.

▶ "Selecting a pattern" (p. 25)

3. Press the [Arp] button to enter Arpeggiator mode.

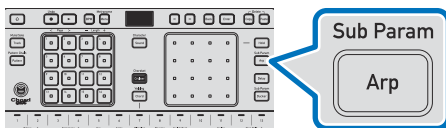

4. Play chords in real time on the keyboard, or press the [Play] button to play a pattern containing chords.

5. Use the XY pad to adjust the effect.

While sound is playing, use the XY pad to adjust the effect's parameters.

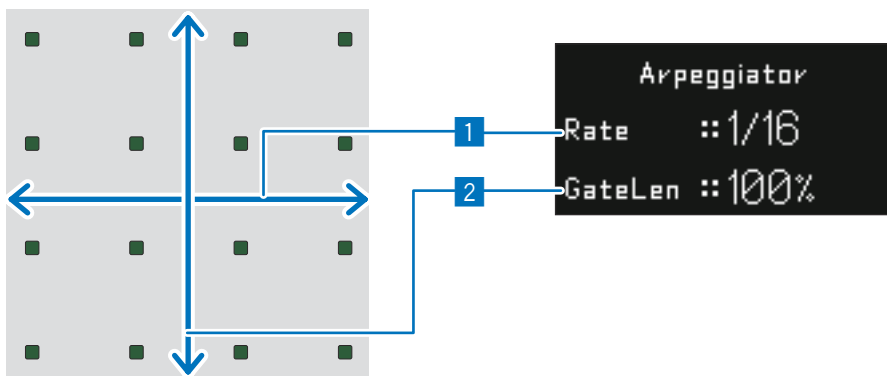

- 1 Sets the speed of arpeggio playing. The further to the right on the XY pad, the faster notes play, and the further to the left, the slower.
(1/8D = Dotted eighth note, 1/xT = Triplet. The default value is 1/16.)
- 2 Sets the length of arpeggio playing. The higher on the XY pad, the longer notes play, and the lower, the shorter.

Note

- If you use the XY pad after pressing the **[Hold]** button, the effect's parameters will stay fixed at their last set values and you'll remain in Arpeggiator mode, even if you stop touching the XY pad (hold state). Press the **[Hold]** button again to cancel the hold state.
- When not in Chord Performance mode, the touch keys on the keyboard will play single notes, and touching multiple touch keys simultaneously will produce chords. In this case, arpeggios will be played according to the chord comprising the notes played on the touch keys.

Arpeggiator advanced settings

1. While pressing the **[↑]** button, press the **[Arp]** button to open the arpeggiator advanced settings screen.

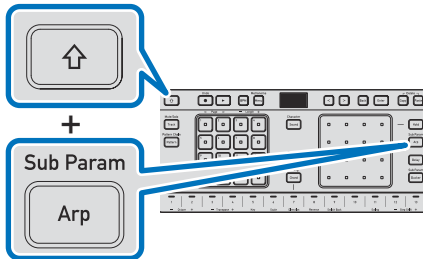

2. Use the XY pad to change setting values.

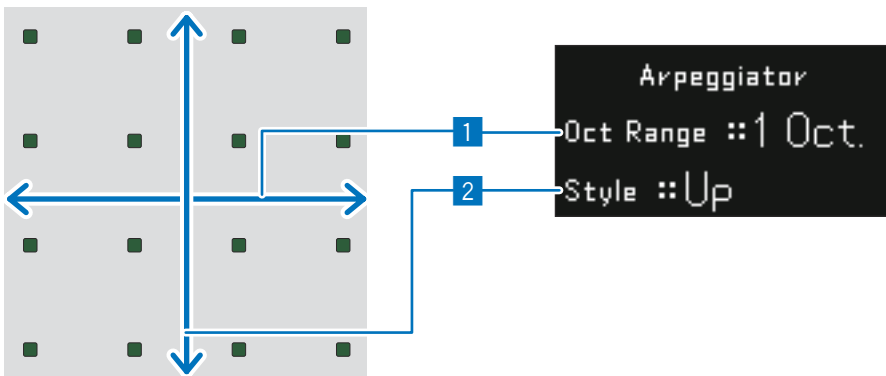

- 1 Sets the arpeggio range in octaves. The arpeggio plays on repeat within the set range.
A chord composed of C, E, G, and high C is used as an example below.

1 Oct.

The chord touched on the keyboard (or played back) is played as an arpeggio.

2 Oct.

The chord touched on the keyboard (or played back) and the same chord one octave above are played as an arpeggio.

Arranging Patterns

3 Oct.

The chord touched on the keyboard (or played back) and the same chord one and two octaves above are played as an arpeggio.

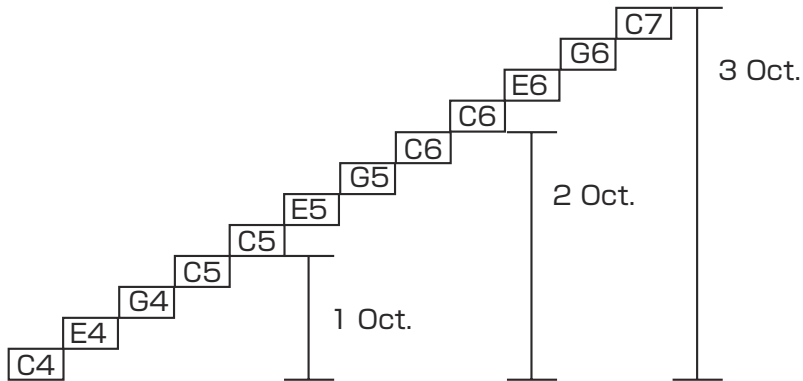

2 Sets the order in which the notes of the arpeggio play.

Example: Using a chord composed of C, E, G, and high C

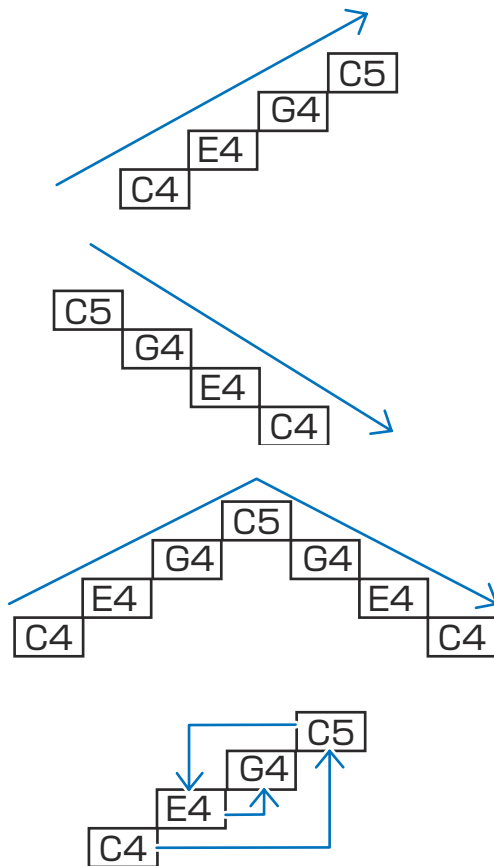

Up

Notes play in order from lowest to highest.

Down

Notes play in order from highest to lowest.

Up+Down

Notes play in order from lowest to highest and, after reaching the highest, back down to lowest.

Random

The notes composing the chord play in a random order.

Using delay

You can apply a delay effect.

1. Select a track.

▶ “Selecting a track” (p. 24)

2. Select a pattern.

▶ “Selecting a pattern” (p. 25)

3. Press the [Delay] button to enter Delay mode.

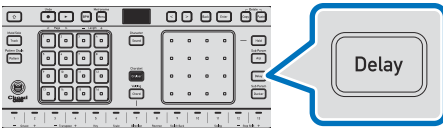

4. Play the keyboard in real time, or press the [Play] button to play the sequence.

5. Use the XY pad to adjust the effect.

Use the XY pad to adjust the effect's parameters.

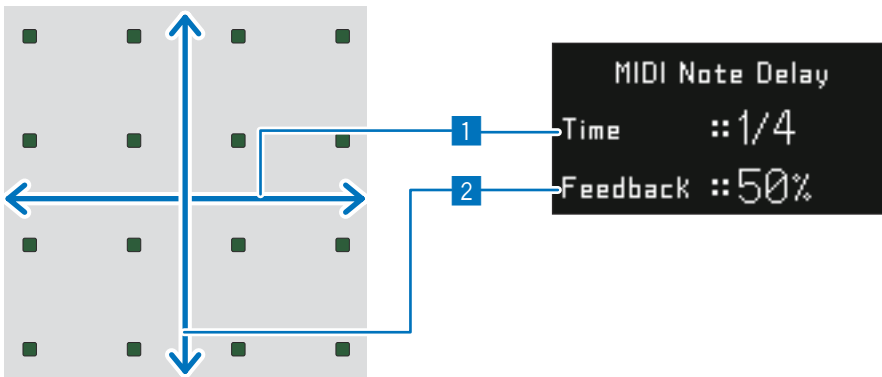

1 Sets the delay time. The further to the right on the XY pad, the shorter the delay, and the further to the left, the longer. (1/8D = Dotted eighth note, 1/xT = Triplet. The default value is 1/4.)

2 Sets the intensity of the feedback (the sound played following the original sound after a delay) as a percentage. The higher on the XY pad, the stronger the feedback, and the lower, the weaker.

Note

- If you use the XY pad after pressing the **[Hold]** button, the effect's parameters will stay fixed at their last set values and you'll remain in Delay mode, even if you stop touching the XY pad (hold state). Press the **[Hold]** button again to cancel the hold state.

Using the ducker

The ducker provides a “ducking” effect that uses cyclic volume changes to alter the groove.

1. Select a pattern and track.

Select the track and pattern you want to apply the effect to.

- ▶ “Selecting a pattern” (p. 25)
- ▶ “Selecting a track” (p. 24)

2. Press the [Ducker] button to enter Ducker mode.

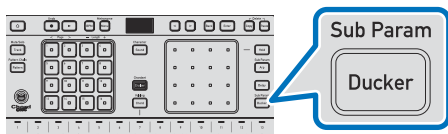

3. Play the keyboard in real time, or press the [Play] button to play the pattern.

4. Use the XY pad to adjust the effect.

While sound is playing, use the XY pad to adjust the effect's parameters.

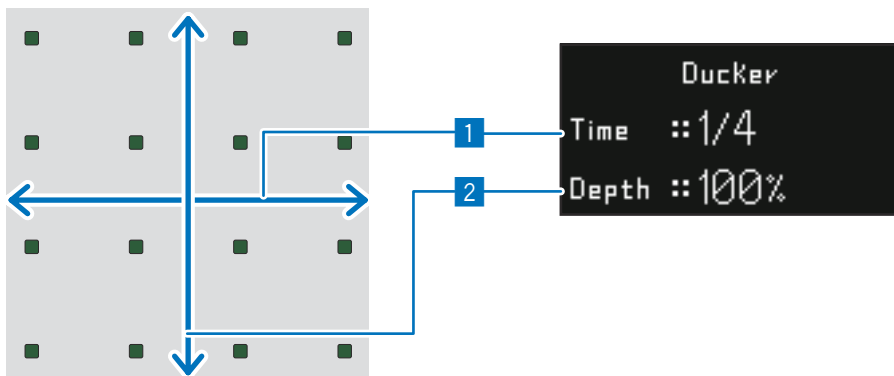

1 Sets the period for volume changes. The further to the right on the XY pad, the shorter the interval of volume changes, and the further to the left, the longer the interval.

(1/8D = Dotted eighth note, 1/xT = Triplet. The default value is 1/4.)

2 Sets the degree to which the volume is raised. The higher on the XY pad, the greater the degree of volume increase, and the lower, the smaller the degree of volume increase.

Note

- If you use the XY pad after pressing the [**Hold**] button, the effect's parameters will stay fixed at their last set values and you'll remain in Ducker mode, even if you stop touching the XY pad (hold state). Press the [**Hold**] button again to cancel the hold state.

■ Ducker advanced settings

1. While pressing the [↑] button, press the [Ducker] button to open the ducker advanced settings screen.

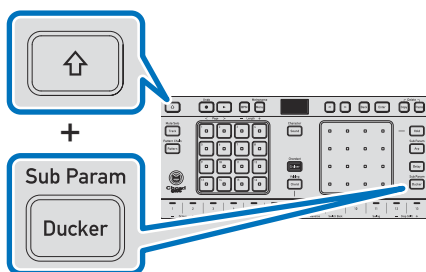

2. Use the XY pad to change setting values.

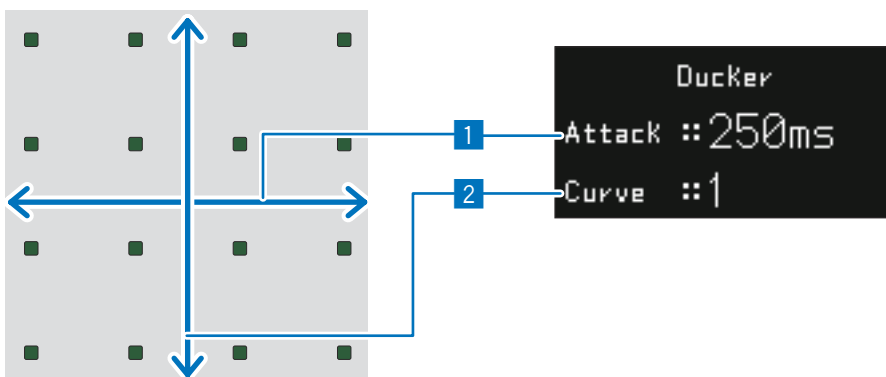

- 1 Sets the amount of time it takes for the volume to return to normal once it has reached its lowest point. The further to the right on the XY pad, the more slowly the volume returns to its original level, and the further to the left, the more rapidly it returns to its original level.
- 2 Sets the volume curve for lowering and raising the volume. Changing the volume curve changes the way it sounds when the volume rises or falls with the beat.
Use the XY pad to select from among the following.

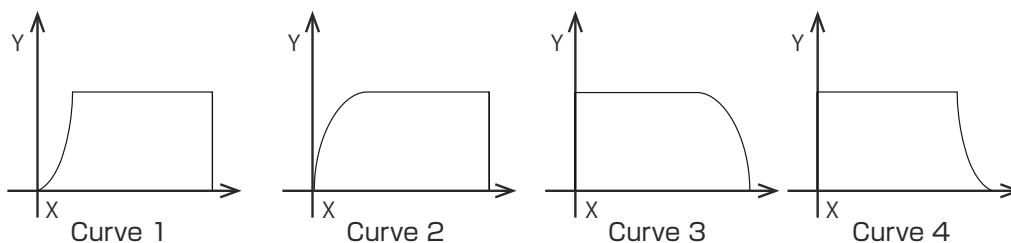

X = Time, Y = Volume

Connecting this product to an external MIDI device for performances

By connecting the **MIDI OUT/THRU** terminal, **MIDI IN** terminal, or **USB** terminal of this product to the MIDI terminal of an external MIDI device (synthesizer, sound module, etc.) or the USB port of a computer, you can synchronize performances between the product and an external MIDI device, or control the product from a computer.

Synchronized performance with an external MIDI device or other device operates according to the BPM of the timing clock of the product or the timing clock of another clock output device. Which timing clock is used depends on the settings of the product.

When a computer and the product are connected with a USB cable, a single cable can be used to send and receive MIDI signals.

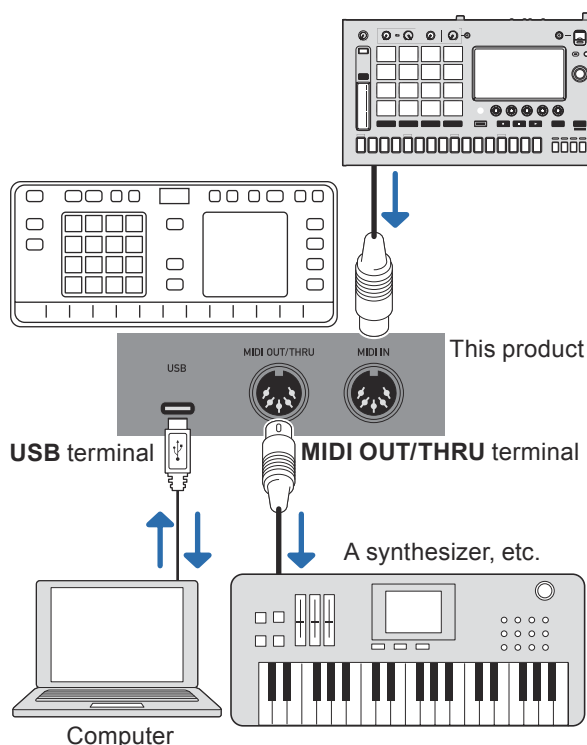

- For details on configuring various MIDI settings, refer to the following.
 - ▶ “Setting MIDI input” (p. 77)
 - ▶ “Setting MIDI output” (p. 78)
 - ▶ “Setting tracks for MIDI output” (p. 82)

Controlling a computer or external MIDI device from this product (using MIDI OUT)

In this configuration, this product is the transmitter, and the computer and external MIDI device are the receivers. The timing clock output from the product is used for synchronization.

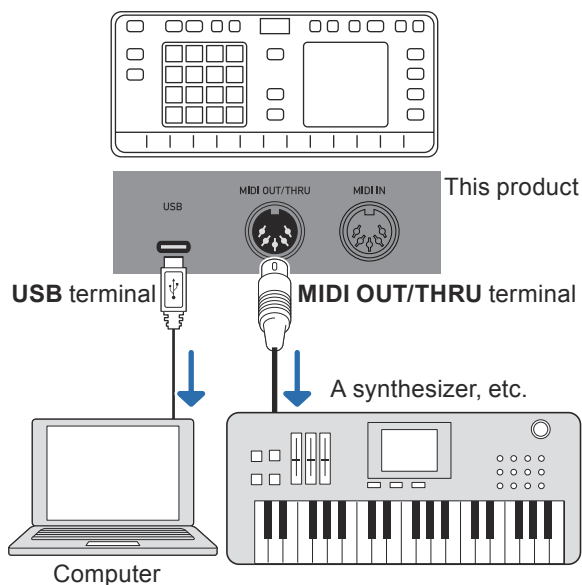

Setting item		Setting to use	Remarks
MIDI IN Settings	Sync Source	Internal	
	MIDI IN Start/Stop	Disable	The setting doesn't matter in this configuration.
MIDI OUT Settings	MIDI OUT/THRU Mode	OUT	
	DIN MIDI Sync OUT	Send	The setting doesn't matter in this configuration.
	DIN MIDI Start/Stop		
	USB MIDI Sync OUT		
	USB MIDI Start/Stop		
Master Clock Out	Continuous	The setting doesn't matter in this configuration.	
Track MIDI Settings	MIDI IN	N/A	The setting doesn't matter in this configuration.
	MIDI OUT	Set each track to one of the following USB Ch.1 – USB Ch.16 MIDI Ch.1 – MIDI Ch.16	Set the computer (DAW) and the external MIDI device to separate channels, and match the respective MIDI receive channels of the computer (DAW) and the external MIDI device accordingly.

Controlling this product or an external MIDI device from a computer

In this configuration, the computer is the transmitter, and this product and the external MIDI device are the receivers.

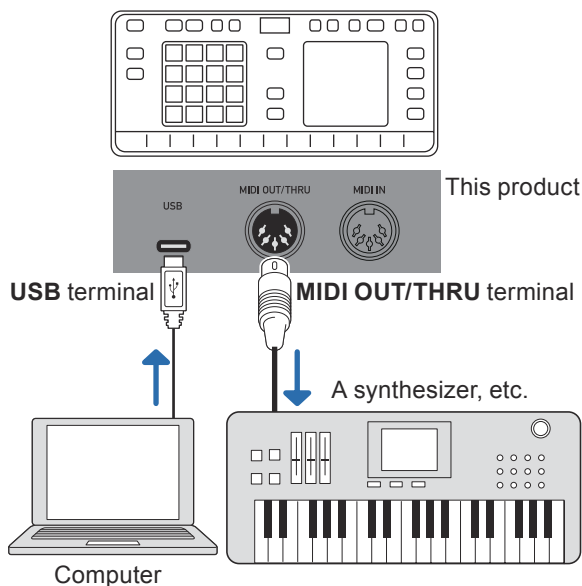

Setting item		Setting to use	Remarks
MIDI IN Settings	Sync Source	USB MIDI	
	MIDI IN Start/Stop	Receive	The setting doesn't matter in this configuration.
MIDI OUT Settings	MIDI OUT/THRU Mode	THRU(USB IN)	
	DIN MIDI Sync OUT	Send	The setting doesn't matter in this configuration.
	DIN MIDI Start/Stop		
	USB MIDI Sync OUT	Disable	
	USB MIDI Start/Stop		
Master Clock Out	Playback only	The setting doesn't matter in this configuration.	
Track MIDI Settings	MIDI IN	Set each track to one of the following USB Ch.1 – USB Ch.16	Match the MIDI send channel of the computer (DAW).
	MIDI OUT	Set each track to one of the following MIDI Ch.1 – MIDI Ch.16	Match the MIDI receive channel of the external MIDI device.

Operating the menu screen

How to operate the menu screen

You can use the menu screen to change various settings.



1. Press the [Menu] button.

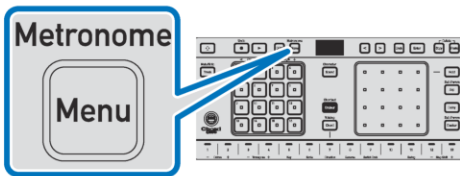

The menu screen appears.

2. Press the [<] or [>] button to select the item you want to set, and press the [Enter] button.

The item will be selected.



If there are items further down the hierarchy, press the [<] or [>] button to select an item, and press the [Enter] button to proceed.

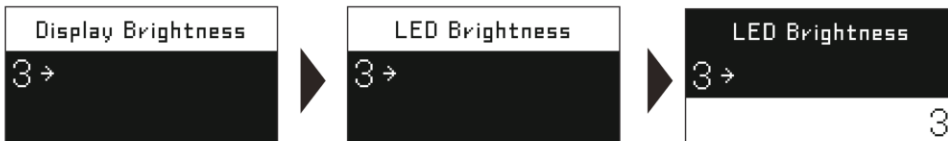

Note

- Press the [Back] button to return the screen to the previous level.

3. Press the [<] or [>] button to change the setting value, and press the [Enter] button.



The setting value is changed and the screen returns to the previous one.

4. Press the [Menu] button to exit the menu screen.

Setting items list

Setting item	Default setting	Reference	
Project	Create New	—	▶ “Creating a new project” (p. 19)
	Open(recent)	—	▶ “Loading a previous project” (p. 21)
	Open(creation)	—	
	Open(name)	—	
	Save	—	▶ “Saving the project” (p. 19)
	Save As	—	
	Rename Save	—	
	Delete	—	
Brightness	Display Brightness	3	▶ “Adjusting the brightness of the main unit display” (p. 77)
	LED Brightness	3	▶ “Adjusting the brightness of the control LEDs.” (p. 77)
MIDI IN Settings	Sync Source	Internal	▶ “Selecting the source you want to synchronize this product with” (p. 78)
	MIDI IN Start/Stop	Receive	▶ “Setting real-time MIDI message reception” (p. 78)
MIDI OUT Settings	MIDI OUT/THRU Mode	OUT	▶ “Configuring MIDI output signals” (p. 79)
	DIN MIDI Sync OUT	Send	▶ “Setting MIDI timing clock transmission (MIDI OUT/THRU terminal)” (p. 79)
	DIN MIDI Start/Stop	Send	▶ “Setting Start/Stop message transmission (MIDI OUT/THRU terminal)” (p. 80)
	USB MIDI Sync OUT	Send	▶ “Setting MIDI timing clock transmission (USB terminal)” (p. 80)
	USB MIDI Start/Stop	Send	▶ “Setting Start/Stop message transmission (USB terminal)” (p. 80)
	Master Clock Out	Continuous	▶ “Setting the timing clock output by this product” (p. 81)
Track MIDI Settings	MIDI IN	Track 1 MIDI IN – Track 8 MIDI IN: USB Ch.1 – USB Ch.8	▶ “Setting tracks for MIDI input” (p. 81)
	MIDI OUT	Track 1 MIDI OUT – Track 8 MIDI OUT: USB Ch.1 – USB Ch.8	▶ “Setting tracks for MIDI output” (p. 82)
Send FX Settings	Reverb	Time: 2000 ms	▶ “Finely adjusting reverb” (p. 82)
	Chorus	Chorus LFO Freq: 0.5079 Hz Chorus Depth: 100 Chorus Feedback: 32	▶ “Finely adjusting chorus” (p. 83)

System Settings	Step Preview	Enable	▶ “Setting the step preview method” (p. 84)
	Auto Power Off	Enable	▶ “Changing the auto power off setting” (p. 84)
	Reset All Settings	—	▶ “Resetting all menu setting items to their defaults” (p. 85)
	System Info.	—	▶ “Displaying system information” (p. 85)

Adjusting the brightness of the main unit display

Carry out the following procedure to adjust the brightness of the main unit display.

1. Press the [Menu] button to open the menu screen.
 - ▶ “How to operate the menu screen” (p. 75)
2. Select the following in order.
Brightness > **Display Brightness**
3. Press the [<] or [>] button to select the desired brightness, then press the [Enter] button.
 The brightness can be set between **1** and **3**. The higher the setting value, the brighter it is.

Adjusting the brightness of the control LEDs

You can adjust the brightness of the LED lights on the controls.

1. Press the [Menu] button to open the menu screen.
 - ▶ “How to operate the menu screen” (p. 75)
2. Select the following in order.
Brightness > **LED Brightness**
3. Press the [<] or [>] button to select the desired brightness, then press the [Enter] button.
 The brightness can be set between **1** and **3**. The higher the setting value, the brighter it is.

Setting MIDI input

You can configure MIDI input settings. These settings apply to both the **MIDI IN** and **USB** terminals.

Applicable terminals



■ Selecting the source you want to synchronize this product with

Select the timing clock synchronization source.

1. Press the [Menu] button to open the menu screen.

▶ “How to operate the menu screen” (p. 75)

2. Select the following in order.

MIDI IN Settings > **Sync Source**

3. Press the [<] or [>] button to select the setting, then press the [Enter] button.

Internal:

Select this setting when you don't need a synchronization source and will use the product as the transmitter.

DIN MIDI:

The product will operate in accordance with the timing clock of the device connected to the **MIDI IN** terminal.

USB MIDI:

The product will operate in accordance with the timing clock of the device connected to the **USB** terminal.

■ Setting real-time MIDI message reception

Set whether to enable or disable the reception of Start, Stop, and Continue MIDI messages at the **USB** and **MIDI IN** terminals.

1. Press the [Menu] button to open the menu screen.

▶ “How to operate the menu screen” (p. 75)

2. Select the following in order.

MIDI IN Settings > **MIDI IN Start/Stop**

3. Press the [<] or [>] button to select the setting, then press the [Enter] button.

Receive:

Enables receipt of Start, Stop, and Continue real-time MIDI messages.

Disable:

Disables receipt of Start, Stop, and Continue real-time MIDI messages. Select this setting when you don't need a synchronization source and will use the product as the transmitter.

Setting MIDI output

You can configure MIDI output settings. These settings apply to the **MIDI OUT/THRU** terminal.

Note

- Regardless of these settings, only MIDI messages output by the product will be output to the **USB** terminal.
-

Applicable terminals

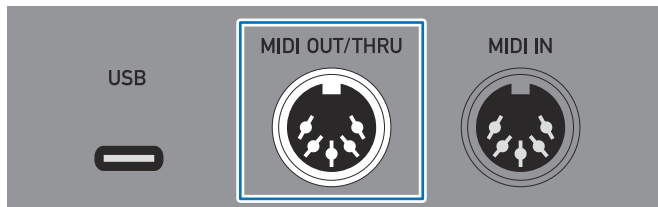

■ Configuring MIDI output signals

You can configure MIDI output signals in accordance with the devices that make up your system and your intended use of MIDI signals, e.g., outputting signals received at the **MIDI IN** or **USB** terminal on the product as-is, or merging the signals before output.

1. Press the [Menu] button to open the menu screen.

▶ “How to operate the menu screen” (p. 75)

2. Select the following in order.

MIDI OUT Settings > **MIDI OUT/THRU Mode**

3. Press the [<] or [>] button to select the setting, then press the [Enter] button.

OUT:

Outputs only MIDI messages that are output by the product.

OUT+MIDI IN:

Merges MIDI messages output by the product with MIDI messages received at the **MIDI IN** terminal before output.

OUT+USB IN:

Merges MIDI messages output by the product with MIDI messages received at the **USB** terminal before output.

OUT+MIDI&USB IN:

Merges MIDI messages output by the product with MIDI messages received at the **MIDI IN** and **USB** terminals before output.

THRU(MIDI IN):

Outputs only MIDI messages received at the **MIDI IN** terminal.

THRU(USB IN):

Outputs only MIDI messages received at the **USB** terminal.

■ Setting MIDI timing clock transmission (MIDI OUT/THRU terminal)

You can choose whether or not to send a timing clock signal from the **MIDI OUT/THRU** terminal.

1. Press the [Menu] button to open the menu screen.

▶ “How to operate the menu screen” (p. 75)

2. Select the following in order.

MIDI OUT Settings > **DIN MIDI Sync OUT**

3. Press the [**<**] or [**>**] button to select the setting, then press the [**Enter**] button.

Send:

Sends the timing clock signal of the product from the **MIDI OUT/THRU** terminal.

Disable:

No timing clock signal is sent from the **MIDI OUT/THRU** terminal.

■ Setting Start/Stop message transmission (MIDI OUT/THRU terminal)

You can choose to enable or disable the transmission of Start and Stop MIDI messages at the **MIDI OUT/THRU** terminal.

1. Press the [**Menu**] button to open the menu screen.

▶ “How to operate the menu screen” (p. 75)

2. Select the following in order.

MIDI OUT Settings > **DIN MIDI Start/Stop**

3. Press the [**<**] or [**>**] button to select the setting, then press the [**Enter**] button.

Send:

Enables the sending of Start and Stop MIDI messages from the **MIDI OUT/THRU** terminal.

Disable:

Disables the sending of Start and Stop MIDI messages from the **MIDI OUT/THRU** terminal.

■ Setting MIDI timing clock transmission (USB terminal)

You can choose whether or not to send a timing clock signal from the **USB** terminal.

1. Press the [**Menu**] button to open the menu screen.

▶ “How to operate the menu screen” (p. 75)

2. Select the following in order.

MIDI OUT Settings > **USB MIDI Sync OUT**

3. Press the [**<**] or [**>**] button to select the setting, then press the [**Enter**] button.

Send:

Sends the timing clock signal of the product from the **USB** terminal.

Disable:

No timing clock signal is sent from the **USB** terminal.

■ Setting Start/Stop message transmission (USB terminal)

You can choose to enable or disable the transmission of Start and Stop MIDI messages at the **USB** terminal.

1. Press the [**Menu**] button to open the menu screen.

▶ “How to operate the menu screen” (p. 75)

2. Select the following in order.

MIDI OUT Settings > **USB MIDI Start/Stop**

3. Press the [**<**] or [**>**] button to select the setting, then press the [**Enter**] button.

Send:

Enables the sending of Start and Stop MIDI messages from the **USB** terminal.

Disable:

Disables the sending of Start and Stop MIDI messages from the **USB** terminal.

■ Setting the timing clock output by this product

When using the product as a transmitting device, you can set the conditions under which timing clock information is sent.

1. Press the [**Menu**] button to open the menu screen.

▶ “How to operate the menu screen” (p. 75)

2. Select the following in order.

MIDI OUT Settings > **Master Clock Out**

3. Press the [**<**] or [**>**] button to select the item you want to set, and press the [**Enter**] button.

Playback only:

Sends the timing clock signal of the product only during playback.

Continuous:

Always sends the timing clock signal.

Continuous is only enabled when **MIDI IN Settings** is set to **Internal**.

Setting tracks for MIDI input/output

■ Setting tracks for MIDI input

You can set the terminal for MIDI signal reception and the MIDI channel for each track.

1. Press the [**Menu**] button to open the menu screen.

▶ “How to operate the menu screen” (p. 75)

2. Select the following in order.

Track MIDI Settings > **MIDI IN**

3. Press the [**<**] or [**>**] button to select the track you want to set, then press the [**Enter**] button.

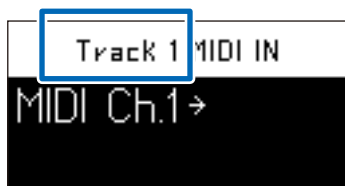

The main unit display shows the currently selected track.

4. Press the [**<**] or [**>**] button to select the setting, then press the [**Enter**] button.

Disable:

Set this when you don't want to use MIDI signal input.

MIDI Ch.1 – MIDI Ch.16:

Uses MIDI signals received at the **MIDI IN** terminal.

USB Ch. 1 – USB Ch. 16:

Uses MIDI signals received at the **USB** terminal.

■ Setting tracks for MIDI output

You can set the terminal for MIDI signal transmission and the MIDI channel for each track.

1. Press the [**Menu**] button to open the menu screen.

▶ “How to operate the menu screen” (p. 75)

2. Select the following in order.

Track MIDI Settings > **MIDI OUT**

3. Press the [**<**] or [**>**] button to select the track you want to set, then press the [**Enter**] button.

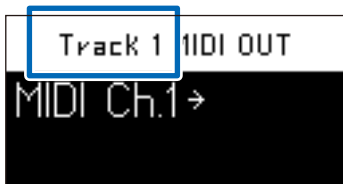

The main unit display shows the currently selected track.

4. Press the [**<**] or [**>**] button to select the setting, then press the [**Enter**] button.

Disable:

Set this when you don't want to use MIDI signal output.

MIDI Ch.1 – MIDI Ch.16:

Sends MIDI signals to the **MIDI OUT** terminal.

USB Ch. 1 – USB Ch. 16:

Sends MIDI signals to the **USB** terminal.

Finely adjusting reverb and chorus

You can finely adjust the settings of the reverb and chorus effects that can be used on each track.

■ Finely adjusting reverb

You can set the reverb time.

 **Note**

- For details on how to apply effects to each track, refer to the following.
 - ▶ “Applying reverb” (p. 60)

1. Press the [Menu] button to open the menu screen.

▶ “How to operate the menu screen” (p. 75)

2. Select the following in order.

Send FX Settings > **Reverb**

3. Press the [Enter] button.



4. Press the [<] or [>] button to adjust the reverb time, and press the [Enter] button.



Adjustment is completed and the screen returns to the previous one.

■ Finely adjusting chorus

Note

- For details on how to apply effects to each track, refer to the following.
 - ▶ “Applying chorus” (p. 60)

1. Press the [Menu] button to open the menu screen.

▶ “How to operate the menu screen” (p. 75)

2. Select the following in order.

Send FX Settings > **Chorus**

3. Press the [<] or [>] button to select the item you want to set, and press the [Enter] button.

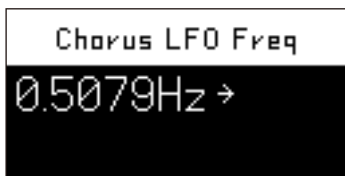

Chorus LFO Freq:

Sets the period of the vibrato effect that modulates the sound. The higher the frequency, the shorter the period of sound modulation.

Chorus Depth:

Sets the degree of the effect. The higher the value, the stronger the effect.

Operating the Settings Menu

Chorus Feedback:

Sets the feedback level. The higher the value, the greater the feedback.

4. Press the [**<**] or [**>**] button to adjust the value, and press the [**Enter**] button.

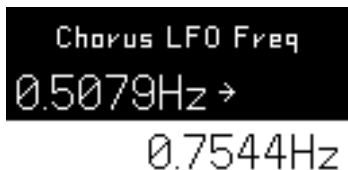

Adjustment is completed and the screen returns to the previous one.

5. Repeat steps 3 and 4 to set the other items.

Setting the step preview method

You can set how the step preview plays when you press and hold a step button.

1. Press the [**Menu**] button to open the menu screen.

▶ "How to operate the menu screen" (p. 75)

2. Select the following in order.

System Settings > **Step Preview**

3. Press the [**<**] or [**>**] button to select the step preview output method, and press the [**Enter**] button.

Disable:

Do not output a step preview.

Enable:

Always output a step preview.

Ena(Mute Cur Tr):

Output a step preview and mute the currently selected track during the preview.

Ena(Mute All Tr):

Output a step preview and mute all tracks during the preview.

Ena(Stop):

Output a step preview only when the sequencer is stopped.

Changing the auto power off setting

To reduce battery drain, the power can be set to automatically turn off after a period of inactivity.

1. Press the [**Menu**] button to open the menu screen.

▶ "How to operate the menu screen" (p. 75)

2. Select the following in order.

System Settings > **Auto Power Off**

3. Press the [**<**] or [**>**] button to select an auto power off setting, and press the [**Enter**] button.

Enable:

Power off after 20 minutes of inactivity and no MIDI input.

Disable:

Do not automatically power off.

Resetting all menu setting items to their defaults

You can reset all adjusted values of setting items in the menu screen to their default states.

1. Press the [**Menu**] button to open the menu screen.

▶ “How to operate the menu screen” (p. 75)

2. Select the following in order.

System Settings > **Reset All Settings**

3. Press the [**<**] or [**>**] button to select **OK**, and press the [**Enter**] button.

The settings will be reset to their defaults.

 **Note**

- Select [**Cancel**] to return to the previous screen without resetting settings to their defaults.
-
-

Displaying system information

You can check the product's system information.

1. Press the [**Menu**] button to open the menu screen.

▶ “How to operate the menu screen” (p. 75)

2. Select the following in order.

System Settings > **System Info.**

3. Check the information displayed.

The system version is displayed.

Troubleshooting

In the event of a problem, please check the following items and the **Frequently Asked Questions (FAQs)** for **CHORDCAT** from the AlphaTheta support page.

alphatheta.com/support/

- Check the devices connected to the product as well.
- Turning the power off and then turning it on again may cause the product to operate normally.

If the problems continue, read the Precautions for Use and consult an authorized service company or your dealer.

- Static electricity and other external factors may cause the product to stop operating normally. In such circumstances, proper operation may be restored by turning the power off, disconnecting and then re-connecting the USB cable, and then turning the power on again. When running the product on batteries, turn off the power, remove and then reinsert the batteries, and then turn the power on again.
- If system operation with an externally connected device or operation of the product becomes unstable, try resetting the menu screen setting items to their defaults and then reconfiguring the relevant items. Some project-related items may not be reset to their defaults, in which case you must check these settings individually.

System Settings > **Reset All Settings**

Issue	Possible cause	Solution
The product power doesn't turn on.	The batteries haven't been inserted properly.	Open the rear cover and check that the batteries are properly inserted. ▶ "Overall flow" (p. 7)
	The batteries are low on power.	The main unit display will show a message when the batteries are low. Replace with new batteries. Do not mix old and new batteries or different battery brands or product lines. ▶ "Overall flow" (p. 7)
	The USB cable isn't connected properly.	Connect the USB cable properly to supply power to the product. ▶ "Overall flow" (p. 7)
	No power is being supplied by the device the USB cable is connected to at the other end.	• If connected to a computer, make sure the computer power is turned on and supplying power to the product. ▶ "Overall flow" (p. 7)
	The [⏻] button hasn't been pressed.	Press and hold the [⏻] button to turn on the product power. The [⏻] button is located on the rear of the main unit. ▶ "Rear" (p. 15)
The main unit display or LED lights on the controls are dim or not lit up.	The product hasn't sent/received signals or been operated for an extended period of time.	If the product isn't operated or doesn't receive MIDI signals for five minutes, the brightness of the main unit display and the physical control lights will automatically dim. After an additional five minutes, the display and lights will turn off. (However, touch key [13] on the keyboard will remain lit.) After operating the unit, the main unit display and LED lights on the controls will return to normal.

The power turns off by itself.	The auto power off function is on and the product hasn't sent/received signals or been operated for an extended period of time.	The power will turn off if the product doesn't send or receive any signals and isn't operated for 20 minutes. Press the [⏻] button again to turn on the product. To change the setting, refer to the following page. ▶ "Changing the auto power off setting" (p. 84)
When the power is turned on again, the product is in a different state.	The product power was turned off without using the [⏻] button.	The product will not resume from the state in which it turned off if the USB cable is unplugged or if the computer supplying USB power is turned off and the power supply is cut off before turning off the product. When turning off the power, use the [⏻] button on the rear of the product to turn it off. ▶ "Rear" (p. 15)
There is no sound from the product.	The product power isn't turned on.	Press the [⏻] button to turn on the product power. The [⏻] button is located on the rear of the main unit. ▶ "Rear" (p. 15)
	The product isn't properly connected to any speakers.	Check that your speakers are properly connected to the MASTER OUT terminals on the rear of the main unit. ▶ "Rear" (p. 15)
No sound is output, even when operating the product.	The volume is low.	Raise the volume. The [VOLUME] button is located on the rear of the main unit. ▶ "Rear" (p. 15)
	Tracks are muted.	No sound is produced when the mute/solo setting is on mute. Refer to the following page for instructions. ▶ "Switching between mute and solo on each track" (p. 61)
The sound is soft.	The volume is low.	Raise the volume. The [VOLUME] button is located on the rear of the main unit. ▶ "Rear" (p. 15)
There's no sound, even after pressing the [Play] button.	The step button triggers aren't turned on.	Press the step buttons to make them light up in a bright green so they'll play sound when you press the [Play] button to start the sequence. ▶ "Turning triggers on/off" (p. 44)
I can't hear the metronome.	The metronome isn't turned on.	While pressing the [⏮] button, press the [Menu] button to turn the metronome on. ▶ "Top panel" (p. 13)
The sound is distorted.	The sound preset items aren't set to the appropriate values.	Set the volume and filter resonance for each category/parameter to the appropriate values. ▶ "Adjusting the low-pass filter" (p. 55)
The device connected to the MIDI OUT/THRU terminal won't operate.	MIDI channels on the transmitting and receiving devices aren't set properly.	Check that the transmission MIDI channel of the transmitting device and the reception MIDI channel of the receiving device are properly set. ▶ "Connecting this product to an external MIDI device for performances" (p. 72)
	The product's MIDI settings aren't appropriate.	Check that the product's MIDI settings match those of the external device. ▶ "Connecting this product to an external MIDI device for performances" (p. 72)

The product can't be controlled from a device connected to the MIDI IN terminal.	The MIDI channels of the transmitting device and the product aren't set properly.	Check that the transmission MIDI channel of the transmitting device and the reception MIDI channel of the product are properly set. ▶ "Connecting this product to an external MIDI device for performances" (p. 72)
The product is connected to a transmitting device but isn't receiving signals.	The transmitting device (master clock transmitter) and the product aren't properly connected.	Check that either the USB terminal or the MIDI IN terminal is properly connected to the master clock transmitter. ▶ "Connecting this product to an external MIDI device for performances" (p. 72)
	MIDI IN setting items aren't properly set.	Properly set the Sync Source setting item under MIDI IN Settings . ▶ "Connecting this product to an external MIDI device for performances" (p. 72)
My computer's DAW software is connected to the product but isn't communicating with it.	The DAW software doesn't recognize the product.	<ul style="list-style-type: none"> Refer to the DAW software's instruction manual or FAQs and check if the product is recognized. Check the USB cable connection. ▶ "Connecting this product to an external MIDI device for performances" (p. 72)
The main unit display is dim.	The brightness of the main unit display hasn't been adjusted.	Adjust to an appropriate brightness. ▶ "Adjusting the brightness of the main unit display" (p. 77)
Chord Cruiser mode doesn't produce chord candidates.	There are no candidates that meet the conditions of the filter applied.	Try changing the root note and chord filter settings used to create chord candidates. ▶ "Creating Chord Patterns" (p. 37)
There are candidate chords that are lit dimly in Chord Cruiser mode.	Chord candidates other than those in the set key/scale are displayed.	The product is operating normally. This is to make it possible to set chords outside of the selected key/scale. ▶ "Creating Chord Patterns" (p. 37)
Undo isn't working.	The operation you're attempting to undo can't be undone.	Not all operations can be undone. See the following for the conditions under which operations can be undone. ▶ "Using the undo function" (p. 54)
Step preview output doesn't work, even after pressing and holding the step buttons.	The step preview function is set to Disable .	If the step preview function is set to Disable , step preview output won't be available. Change the setting. ▶ "Setting the step preview method" (p. 84)

Detailed project structure

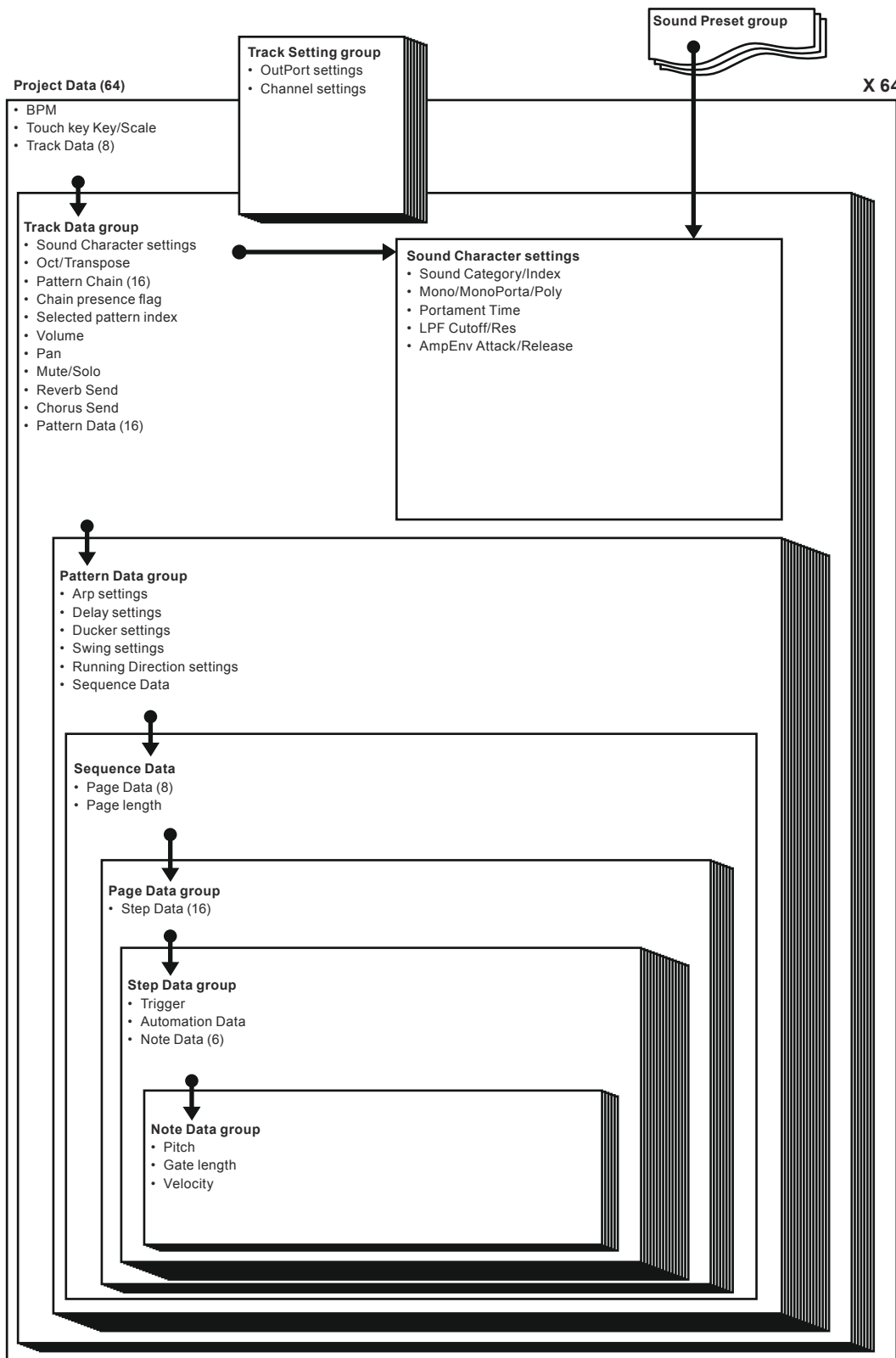

Trademarks and registered trademarks

- USB Type-C and USB 2.0 Type-C are registered trademarks of the USB Implementers Forum.
- The names of companies and products mentioned herein are trademarks or registered trademarks of their respective owners.

Licenses

Apache

Copyright (c) 2009-2019 ARM Limited. All rights reserved.

SPDX-License-Identifier: Apache-2.0

Licensed under the Apache License, Version 2.0 (the License); you may not use this file except in compliance with the License.

You may obtain a copy of the License at

www.apache.org/licenses/LICENSE-2.0

Unless required by applicable law or agreed to in writing, software distributed under the License is distributed on an AS IS BASIS, WITHOUT WARRANTIES OR CONDITIONS OF ANY KIND, either express or implied. See the License for the specific language governing permissions and limitations under the License.

BSD

The BSD-3-Clause License

Copyright (c) 2015, Freescale Semiconductor, Inc.

Copyright 2016-2020 NXP

All rights reserved.

Redistribution and use in source and binary forms, with or without modification, are permitted provided that the following conditions are met:

1. Redistributions of source code must retain the above copyright notice, this list of conditions and the following disclaimer.
2. Redistributions in binary form must reproduce the above copyright notice, this list of conditions and the following disclaimer in the documentation and/or other materials provided with the distribution.
3. Neither the name of the copyright holder nor the names of its contributors may be used to endorse or promote products derived from this software without specific prior written permission.

THIS SOFTWARE IS PROVIDED BY THE COPYRIGHT HOLDERS AND CONTRIBUTORS "AS IS" AND ANY EXPRESS OR IMPLIED WARRANTIES, INCLUDING, BUT NOT LIMITED TO, THE IMPLIED WARRANTIES OF MERCHANTABILITY AND FITNESS FOR A PARTICULAR PURPOSE ARE DISCLAIMED. IN NO EVENT SHALL THE COPYRIGHT HOLDER OR CONTRIBUTORS BE LIABLE FOR ANY DIRECT, INDIRECT, INCIDENTAL, SPECIAL, EXEMPLARY, OR CONSEQUENTIAL DAMAGES (INCLUDING, BUT NOT LIMITED TO, PROCUREMENT OF SUBSTITUTE GOODS OR SERVICES; LOSS OF USE, DATA, OR PROFITS; OR BUSINESS INTERRUPTION) HOWEVER CAUSED AND ON ANY THEORY OF LIABILITY, WHETHER IN CONTRACT, STRICT LIABILITY, OR TORT (INCLUDING NEGLIGENCE OR OTHERWISE) ARISING IN ANY WAY OUT OF THE USE OF THIS SOFTWARE, EVEN IF ADVISED OF THE POSSIBILITY OF SUCH DAMAGE.

Specifications

General - Main Unit

Power supply	
USB bus power.....	DC 5 V, 500 mA
AA/LR6 alkaline battery x6	
Battery life.....	Approximately 5 hours (when using alkaline batteries) *Varies depending on the usage conditions.
Main unit weight.....	0.4 kg (0.9 lb.) (excluding batteries)
Main dimensions.....	(W x D X H) 247 x 111 x 33 mm (9.72" x 4.37" x 1.30")
Tolerable operating temperature.....	+5 °C – +35 °C (+41 °F – +95 °F)
Tolerable operating humidity.....	5% – 85% (no condensation)

Input/Output terminals

Master Audio R output terminal	
1/4" TS jack.....	1 set
Master Audio L/MONO output terminal	
1/4" TS jack.....	1 set
Headphones output terminal	
3.5 mm stereo mini jack.....	1 set
MIDI OUT/THRU output terminal	
5PIN DIN.....	1 set
MIDI IN input terminal	
5PIN DIN.....	1 set
USB terminal	
USB Type-C.....	1 set

- The specifications and design of this product are subject to change without notice.
- Batteries are not included.

© 2024 AlphaTheta Corporation. All rights reserved.

<DRI1900-A>