



**Darkglass Electronics**

*Your vision, our gear.*

OWNER'S MANUAL

# DESCRIPTION

Alpha-Omega 500 is a 500W amplifier equipped with an all-analog preamplifier, a new superior custom-designed Darkglass high efficiency class-D power module and a digital impulse response cabinet emulator for DI outputs or headphones.

Probably the first thing you will notice about Alpha-Omega 500 is its unusual control layout:

On the right side you'll find the clean section, which is the foundation of your sound. It features a Master volume knob and an active 6-band EQ. Along with the mandatory Low and Treble controls, you will find 250Hz, 500Hz, 1.5kHz, and 3kHz sliders. Having these four dedicated Mid controls allows you to have full reign over the amplifier's character.

On the left side, by the input jack you will find the Alpha-Omega® Engine which acts as an extra channel. This creation differs greatly from our previous preamplifiers and overdrives: its operational-amplifier topology featuring two distinct distortion circuits (Alpha and Omega), which can be selected or blended using the Mod knob, make Alpha-Omega the most flexible among our designs.

The Alpha-Omega Engine can be engaged from the front panel or via our own digitally controlled Intelligent Footswitch, which is housed in an elegant, laser engraved unibody chassis and requires a standard ¼" mono cable (not included) for its operation.

A much requested new feature is the cabinet simulation, which utilizes an improved version of our Cab Sim module. The module has three slots for hi-res impulse responses, which are active for both the headphone output and the balanced XLR DI output. The impulse responses can be assigned to the slots via the USB-C connection using the Darkglass Suite on your PC or Mac.

All of these features combined firmly place Alpha-Omega 500 among the most versatile amplifiers on the market. In fact, we here at Darkglass strongly believe that never before has such a powerful tool been packed into such a light and compact format!

# FEATURES

## FRONT PANEL



**INPUT** : Use this jack to connect your instrument via a standard ¼" mono cable.

**PASSIVE/ACTIVE** : Use this push button switch to change from passive to active mode. If your bass is active, it can have a hotter signal that makes the amp distort early (but feel free to use if such additional distortion is desired!).

**DISTORTION**: Use this push button to turn the Alpha-Omega Engine on or off to add natural compression, organic harmonic enhancement, and saturation ranging from mild overdrive to high gain bass rage.

The Alpha-Omega Engine operates before the clean section (you can therefore use the 6-Band Active EQ for additional tone shaping).

**BITE:** Boosts high mids (2.8kHz) for additional presence and definition.

**GROWL:** Shelving Bass Boost for a fatter tone and increased low-end saturation.

**COMPRESSION:** This knob controls the amount of dynamic compression added to the Alpha·Omega Engine. The makeup gain is adjusted automatically. Compression can be turned off or assigned using the Darkglass Suite.

**DRIVE :** This knob controls the amount of distortion that the Alpha·Omega Engine will deliver. It will change from a soft, warm overdrive to a massive, modern distortion sound.

**LEVEL :** Use this knob to control the output volume of the Alpha·Omega Engine.

**BLEND :** Use this knob to mix between the Clean signal and the Distortion signal (Alpha·Omega Engine).

**MOD:** Selects or mixes between the two distinct distortion circuits: Alpha is punchy and tight with a lot of definition, whereas Omega is simply brutal and raw.

**BASS :** +-12dB at 80Hz. Use this slider to change the low-end content of the signal.

**MIDS:** +-12dB at 250, 500, 1.5k and 3kHz. These sliders control the mid content of the signal.

**TREBLE :** +-12dB at 5kHz. Use this slider to change the high content of the signal.

**MASTER :** Use this knob to control the overall volume of the amplifier.

**MUTE :** Use this push button to mute the amplifier.

# FEATURES

## REAR PANEL



**SPEAKER OUTPUT** : Use this connector to connect the amplifier to your cabinet. This Speakon combo jack allows for either Speakon or ¼" speaker cable operation.

**WARNING:** Do not use an instrument cable with this jack. Using an instrument cable can damage your amplifier.

**SEND** : Use this output to send the signal to effects pedals.

**RETURN** : Use this input to receive the signal from effects pedals. Master volume control is after this input.

**GROUND LIFT** : Use this control to lift the ground of the XLR DI output. If you are experiencing ground noise in your DI signal, try changing the setting of this control.

**DI OUTPUT**: Use this connector to send your signal to the console, mic preamp, interface, etc. Both signals are available (bypass and the amp signal with cabinet simulation) and are switched using the cab select switch.

**USB**: The USB connector allows you to use the Darkglass Suite to load different cabinet impulses or change different parameters on your amp.

**HEADPHONE OUTPUT**: Connect your headphones and enjoy the impulse-based cabinet emulation.

**AUX IN**: Use this connector to play music from your laptop, phone, MP3 player, etc. This input is routed only to the headphone output.

**CABINET SELECT**: Use this switch to navigate between the 3 different cabinet impulses or the clean DI signal.

**FOOTSWITCH** : The Intelligent Footswitch is a proprietary digitally controlled device that allows you to remotely engage and disengage the Alpha-Omega Engine. You can also hold the footswitch to Mute the amplifier. The distortion push button will remain operational with the Intelligent Footswitch plugged in.

· **You can use a regular mono instrument cable to connect the amplifier to the footswitch.**

· **You must remove the cable from the footswitch jack in the rear panel if you want to control the amp from the front panel.**

**AC SOCKET** : Use this connector to feed electric power to the amplifier. 100 - 230 VAC, 50-60Hz. **SET THE VOLTAGE SELECTOR SWITCH TO THE CORRECT POSITION BEFORE TURNING ON THE AMPLIFIER!**

**AC POWER ON/OFF** : Use this Switch to release the audio energy from your bass.

# BLOCK DIAGRAM

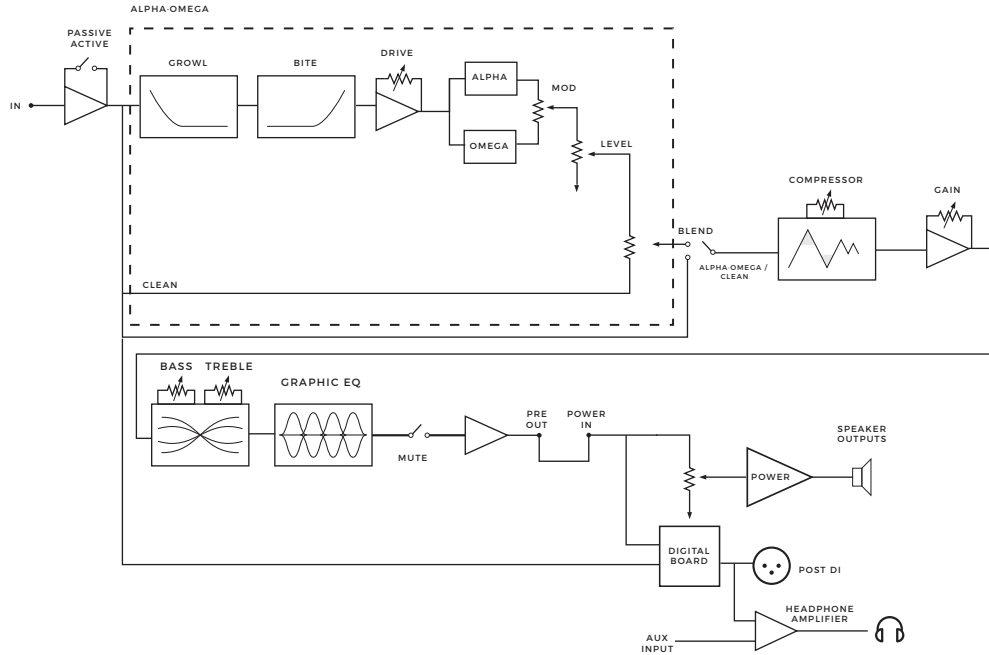

# WARRANTY AND SPECS

## WARRANTY

Please register for your warranty at <http://mypedal.darkglass.com>. The Alpha-Omega 500 is under warranty to the original owner for a period of two years against manufacturing defects in the country where the product was originally purchased.

If you experience a problem with the unit, please contact [support@darkglass.com](mailto:support@darkglass.com) to receive a Return Authorization number or for information on the nearest authorized repair center. A copy of your original receipt must be included with all warranty repairs. You are responsible for all shipping charges. The unit must be shipped to us freight prepaid. We will return the unit freight collect.

Darkglass Electronics Oy is not responsible for shipping damage either to or from our service center. Claims must be filed with the carrier. For repairs please contact your local dealer or distributor for your country's specific warranty period and repair procedures.

Darkglass® and Alpha-Omega® are registered trademarks of Darkglass Electronics Oy.

## SPECIFICATIONS

**Input Impedance:** 1M $\Omega$

**Minimum Load Impedance:** 3 $\Omega$

**Maximum Power Output:** 500 W RMS @ 4 $\Omega$   
250 W RMS @ 8 $\Omega$

**Power Amp Input Impedance:** 1M $\Omega$

**Power Amp Input Level:** 2400 mV RMS

**Pre-Amp Output Impedance:** 1k $\Omega$

**Pre-Amp Output Level:** 2400 mV RMS

**Maximum Power Consumption:** approx. 700VA  
Forced-air cooled

**AC Input Power:** 100-120/210-250 VAC (Via selector switch on left side panel).

**Cycles:** 50/60 Hz

**Dimensions:** 18.0 cm x 7.1 cm x 23.0 cm, l x h x w,  
(7.1" x 2.8" x 9.1")

**Weight:** 2.4 kg (5.29 lbs)

Built and Engineered in Helsinki, Finland.  
(00358) 504 757005

# WARNING

- There are no user-serviceable parts inside the amplifier. Do not open the amp.
- Never use the amp in a high moisture environment or near liquids.
- Alpha-Omega 500 can deliver more than 115 dB of power. Exposure to this level of sound can damage your hearing. Always use proper hearing protection when exposed.
- Alpha-Omega 500 can deliver more than 500 watts. Be sure that your speaker cabinet is able to deliver that power.
- Do not cover the vent holes. The fan and vent holes are part of the cooling system of the amp. Covering the vent holes can lead to overheating and damage to the amplifier.
- Do not use an instrument cable as speaker cable. An instrument cable is not designed to deliver the type of power sent from the amplifier to the speaker.

## TROUBLESHOOTING

- The button controls do not react: check if the footswitch is connected. If you do not want to use the footswitch, you have to unplug the cable from the rear panel of the amp.
- The amp does not turn on: check if the power cable is connected and if you have power on the wall.
- The sound is low: check your speaker cable. Never use an instrument cable.
- The sound is distorted or too high: check if the passive/active switch matches your bass.



**Darkglass Electronics**

*Your vision, our gear.*

FOLLOW US

