

## XANA Line Array System



Operating instructions

## **Contents**

<b>1 Safety instructions and warning symbols .....</b>	<b>1</b>
1.1 General information.....	1
1.2 Intended use .....	1
1.3 Explanation of symbols and terms.....	2
1.4 Safety instructions .....	3
<b>2 Packaging.....</b>	<b>6</b>
2.1 Note .....	6
2.2 Scope of delivery.....	6
<b>3 System components.....</b>	<b>7</b>
3.1 XANA L-208 TA Line Array Top 1,400W .....	7
3.1.1 Mechanics .....	7
3.1.2 Electronics .....	9
3.2 XANA L-118 SA line array subwoofer 2,400W.....	10
3.2.1 Mechanics .....	10
3.2.2 Electronics .....	12
3.3 Accessories.....	13
3.3.1 XANA L-208 TA flying frame incl. flybar .....	13
3.3.2 XANA L-118 SA flying frame incl. flybar .....	14
3.3.3 XANA L-208 TA Transport Dolly .....	15
3.3.4 Other accessories.....	16
<b>4 DSP settings .....</b>	<b>19</b>
4.1 XANA L-208 TA.....	19
4.1.1 Start screen .....	19
4.1.2 Main menu.....	19
4.1.3 Submenu .....	20
4.2 XANA L-118 SA .....	22
4.2.1 Start screen .....	22
4.2.2 Main menu.....	22

4.2.3 Submenu .....	22
<b>5 P.sysMANAGER - Software.....</b>	<b>25</b>
<b>6 EASE Focus 3 - Software .....</b>	<b>26</b>
<b>7 Load limits.....</b>	<b>27</b>
7.1 XANA L-208 TA flying frame incl. flybar.....	28
7.2 XANA L-118 SA flying frame incl. flybar .....	29
<b>8 Assembly.....</b>	<b>30</b>
8.1 Connections .....	31
8.1.1 Locking pin with locking mechanism .....	31
8.1.2 Connecting bolt with safety split pin .....	32
8.2 Transport dolly .....	33
8.2.1 Adjusting the base plate.....	33
8.2.2 Fixing the top section to the base plate.....	34
8.2.3 Fixing top section to top section .....	35
8.3 Ground stack.....	36
8.3.1 Fixing subwoofer to subwoofer.....	36
8.3.2 Flying frame on subwoofer.....	37
8.3.2.1 Using the Xana L-118 SA flying frame.....	37
8.3.2.2 Using the Xana L-208 SA flying frame with stand base .....	38
8.3.3 Fixing the top section to the flying frame .....	39
8.3.4 Fixing the top section to the top section .....	40
8.4 Flown system without subwoofer.....	41
8.4.1 Fixing the flying frame to top sections with transport dolly.....	41
8.4.2 Fixing flying top section on top section with transport dolly .....	43
8.5 Flown system with subwoofer.....	45
8.5.1 Fixing the L-118 SA flying frame to the subwoofer .....	45
8.5.2 Fixing the L-118 SA flying frame under the subwoofer .....	46
8.5.3 Fixing the top section under the L-118 SA flying frame of the transport dolly .....	47
8.5.4 Fixing the top section to the top section of the transport dolly .....	49

<b>9 Specifications .....</b>	<b>51</b>
9.1 XANA L-208 TA Line Array Top 1,400W .....	51
9.2 XANA L-118 SA line array subwoofer 2,800W.....	52
9.3 XANA L-208 TA flying frame .....	53
9.4 XANA L-118 SA flying frame .....	53
<b>10 Maintenance.....</b>	<b>53</b>
<b>11 Cleaning .....</b>	<b>55</b>

© 2025

These operating instructions are protected by copyright. Reproduction of these operating instructions, even in part, is only permitted with the authorisation of Musikhaus KIRSTEIN GmbH. The same applies to the reproduction or copying of images, even in modified form.

Thank you for choosing a product from PRONOMIC. You have made a good choice. PRONOMIC has been synonymous with high-quality audio products at a fair price-performance ratio for many years. You can find more information about the XANA series at <https://www.kirstein.de/Xana> . We wish you many interesting and successful projects using the XANA line array series.

## **1 Safety instructions and warning symbols**

### **1.1 General information**

Please read these operating instructions carefully and completely before using the XANA line array system. Only then, a safe and trouble-free operation is guaranteed.

If any formulations, specifications or procedures in these instructions are unclear to you, do not use the system under any circumstances.

Observe the warnings on the device and in the operating instructions.

Keep these operating instructions in a safe place within easy reach. The operating instructions are an integral part of the product and must be passed on to all subsequent users.

### **1.2 Intended use**

The devices of the Pronomic XANA series have been developed for professional audio applications. Therefore, they are only intended for use by qualified personnel with specialist knowledge. These devices are not suitable for domestic use. Any use outside the described technical data and application conditions is considered improper use!

The products of the XANA Line Array series are not suitable for children and persons with insufficient experience and training. No liability is accepted for damage, including damage to third parties and their property, caused by improper use.

All information in these operating instructions have been checked to the best of our knowledge and belief. However, neither the author nor the publisher can be held liable for any damages related to the use of these operating instructions.

Other product, brand and company names mentioned in this document may be the trademarks of their respective owners. Compliance with all applicable copyright laws is the responsibility of the user of this document.

### 1.3 Explanation of symbols and terms



The manual refers the user to additional information on the product.



The exclamation mark draws the user's attention to important information in the operating instructions that must be observed.



The hearing protection warns the user of the dangers of high volumes.



The flash warns the user of the dangers of electric current and magnetic fields.

#### **DANGER**

Indicates an immediately life-threatening situation. Failure to comply poses an acute danger to life and limb. Can be supplemented by a symbol.

#### **WARNING**

Indicates a potentially hazardous situation which, if not avoided, could result in serious injury or death. Can be supported by a symbol.

#### **NOTE**

The signal word NOTICE indicates general precautionary measures that should be observed when handling the product. Can be supplemented by a symbol.

## 1.4 Safety instructions

These operating instructions apply to persons who have been supervised or instructed in the operation of the appliance by a person responsible for their safety and who have demonstrated that they are able to handle the appliance.



**Children should be supervised to ensure that they do not play with the appliance.  
Do not leave children unattended.**



**DANGER**

Never disassemble your appliance. An incorrectly repaired appliance can be dangerous for the user. If you have any problems, please contact our service centre.

Comply with the trade association regulation "BGV A2 - Electrical systems and equipment".

Do not use the appliance near water (e.g. near a bathtub, washbasin, sink, in a damp cellar or near a swimming pool, etc.).

Check the mains cable for damage before each use. If you notice any damage, the mains cable must be replaced.

The speaker system must not be set up near heat sources such as radiators, fan heaters or other devices that generate heat. The speakers must be protected from direct sunlight, as this can cause the electronics to fail due to overheating.

The appliance may only be connected to a power supply that corresponds to the type described in the operating instructions or indicated on the appliance.

The product should be serviced by qualified service personnel if:

- objects have fallen into the appliance or liquid has been spilled on the appliance
- The device was exposed to rain
- The device does not appear to be functioning normally or there is a significant change in performance
- The device has been dropped or the housing has been damaged
- Do not attempt to service the appliance beyond the measures described in the maintenance instructions. All other maintenance work should be carried out by qualified service personnel.

**WARNING**

This loudspeaker system can generate sound levels that can lead to permanent hearing loss. During operation, ensure that you comply with the legal requirements for accident prevention and the "BGV B3 - Noise" of the employers' liability insurance association.

Do not operate the device at a high volume or at a level that is uncomfortable for a long period of time. If you notice hearing loss or ringing in your ears, you should consult an ear specialist.

Wear hearing protection during operation and do not stand in the immediate vicinity of the speakers.

Never climb on the hanging or standing system.

**NOTE**

Read all instructions before using the product.

Images and screen displays in these operating instructions may differ slightly from the appearance of the actual product as long as this has no negative impact on the technical properties and safety of the product.

All personal formulations in these operating instructions are to be regarded as gender-neutral.

The warranty is void if the product is damaged due to improper use.

Make sure that no objects fall into the openings of the housing and that no liquids penetrate.

Do not cover any ventilation openings.

Protect the speaker system from rain or moisture. The operating temperature range is between +40°C and -5°C.

**DANGER**

Only use the accessories specified by the manufacturer.

Ensure that suitable protective clothing is worn during assembly and dismantling and observe all relevant accident prevention regulations.

During assembly and dismantling, mechanically moving devices and falling parts can pose a considerable risk of injury. Therefore, please observe the relevant trade association regulations:

- DGUV Regulation 54 - "Winches, lifting and pulling equipment"
- DGUV Regulation 1 - "Principles of prevention"
- DGUV Regulation 17 - "Event and production venues for scenic presentation"

DGUV Information 215-313 "Loads above persons" must also be observed.

The mounting accessories supplied with the XANA line array system or specially designed for this purpose must also be checked for wear and functionality at least once a year - or in accordance with applicable local regulations. Particular attention must be paid to signs of corrosion, bending, material fatigue or other impairment of stability.

The respective inspection and maintenance specifications of the manufacturer apply to other slings.

Before any installation, a competent person with experience and training in handling speaker suspension systems should carefully check all components and connections.

The structure is designed for operation in enclosed spaces (exhibition halls, event halls, etc.). Outdoor operation is permitted, provided that the wind loads at the top and bottom ends are transferred horizontally and the structure is lowered at wind speeds above 8 Bft.

All slings must be dimensioned, planned and their installation monitored by specialised personnel in accordance with the explanations in DGUV Information 215-313 (BGI 810-3) on DGUV Regulation 17 (UVV BGV-C1).

All connections must be secured against loosening.

Please refer to the information in IGWV Guideline SQ P1 regarding protective equipotential bonding, lightning protection and defect testing of the components used.

## 2 Packaging

### 2.1 Note



Open the shipping carton carefully and check for visible damage. Each PRONOMIC XANA Series device is fully tested and inspected before leaving the factory and should arrive in perfect condition. If you notice any damage, notify the shipping company immediately. Save the carton and all packing materials for inspection by the carrier.

### 2.2 Scope of delivery

#### XANA L-208 TA Line Array Top

- 1x L-208 TA Line Array top unit
- 1x operating instructions
- 1x mains cable

#### XANA L-118 TA Line Array Subwoofer

- 1x L-118 SA line array subwoofer
- 1x operating instructions
- 1x mains cable

#### XANA flying frame L-208 TA and L-118 SA

- 1x flying frame
- 1x flybar
- 1x operating instructions

#### XANA L-208 TA and L-118SA Transport Dolly

- 1x transport dolly
- 4x swivel castor
- 1x operating instructions

### 3 System components

#### 3.1 XANA L-208 TA Line Array Top 1,400W

##### 3.1.1 Mechanics

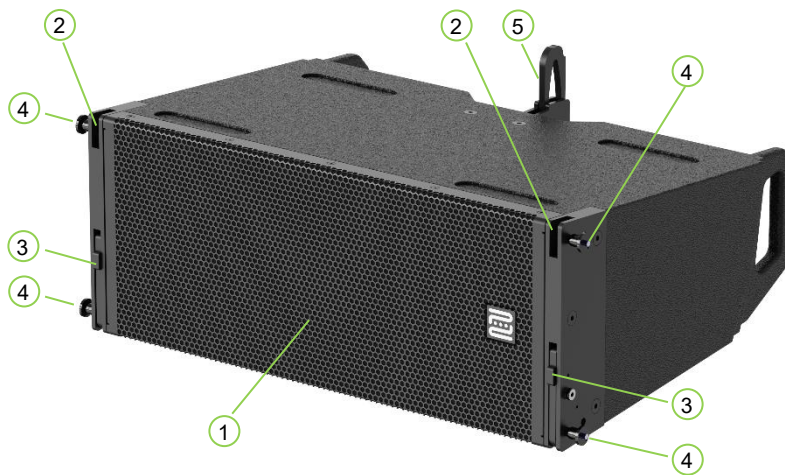

**No. Description of the**

- 1 XANA L-208 TA top
- 2 Connection opening for attaching the speaker to the front connecting slide of the flying frame or the top section above it
- 3 Front connecting slide for attaching an additional L-208 TA top unit
- 4 Socket pin with locking mechanism
- 5 Load bracket for connecting the speaker to the flying frame or for connecting to the top above it

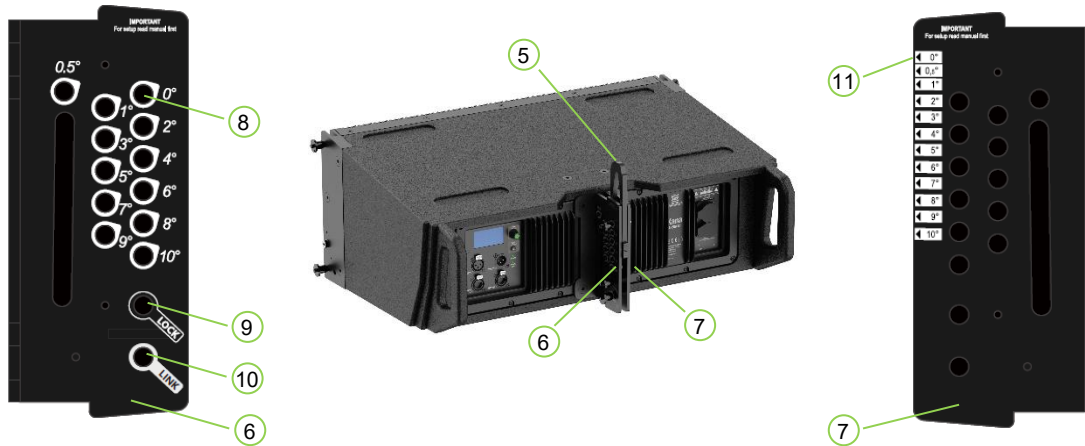

**No. Description of the**

- 5 Load bracket for connecting the speaker to the flying frame or for connecting to the top above it
- 6 Mounting rail (left side) incl. load bracket
- 7 Mounting rail (right-hand side) incl. load bracket
- 8 12 plug-in positions for the connecting pin to set the desired angle between 0.5° and 10°. This is used to fix the load bracket (5).
- 9 Plug-in position (LOCK) for fixing the position of the load bar of an L-208 TA top unit
- 10 Plug-in position (LINK) for mounting the load bracket of an L-208 TA top underneath
- 11 Imprint for checking the angle setting of 0.5°-10°. The angle is set with the arrow pointing to the marking (groove) in the load bracket (see Fig. 2)
- 12 Marking (groove) in the load bar

**Example:**

Image 1: Socket pin was set at 10°

Image 2: Groove in the load bracket points to 10° marking

Picture 1

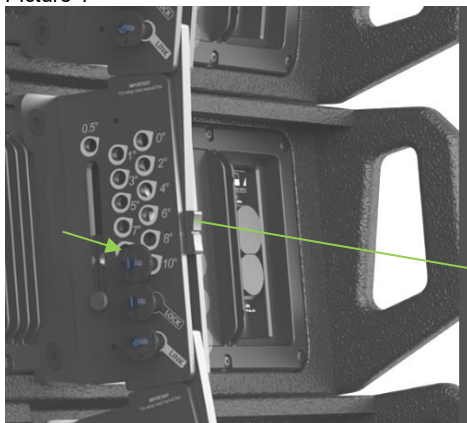

Picture 2



12

## 3.1.2 Electronics

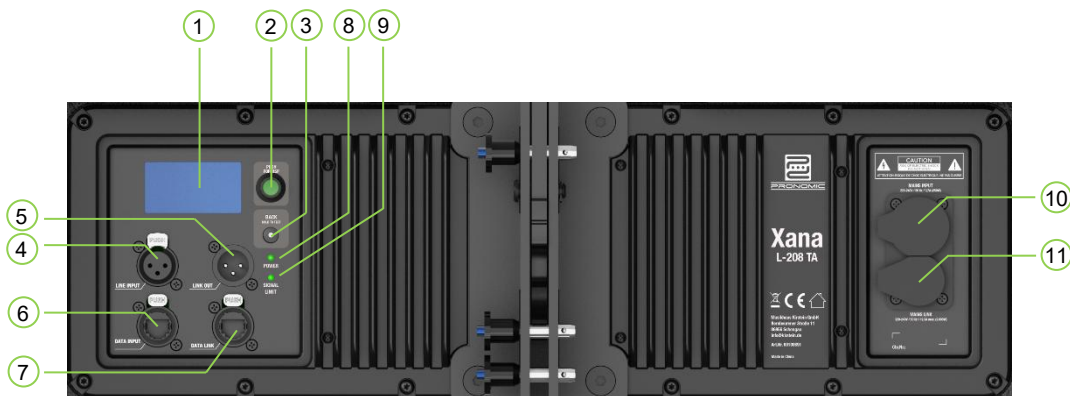

### No. Description of the

- 1 **LCD screen:** Provides access to speaker operating modes, DSP parameters, network settings and more
- 2 **PUSH FOR DSP:** Rotary control for parameter setting with push function to confirm the choice.
- 3 **BACK & HOLD TO TEST:** Button is used in conjunction with the rotary control to control the parameters displayed on the LCD screen.  
Short press = "back"  
Long press = (>5 sec.) starts a frequency sweep signal for speaker test
- 4 **LINE INPUT:** XLR input (balanced)  
The input signal is fed directly to the DSP.
- 5 **LINE OUT:** XLR output (balanced)  
The output receives the direct signal from the input and bypasses the DSP so that there is no latency. The output continues to function even in the event of a power failure.
- 6 **DATA INPUT:** etherCON network socket for controlling the parameters via RS485 protocol.
- 7 **DATA LINK:** etherCON network socket for connecting an additional device.
- 8 **POWER:** LED indicates whether the device is supplied with power.
- 9 **SIGNAL / LIMIT:** LED indicates whether signal is present or the amplifier is being overdriven
- 10 **MAINS INPUT:** Power connection input (powerCon True1 compatible)
- 11 **MAINS LINK:** Power connection output (powerCon True1 compatible) is used to supply power to other devices. ATTENTION: Do not exceed the max. power specifications.

**3.2 XANA L-118 SA line array subwoofer 2,400W**

3.2.1 Mechanics

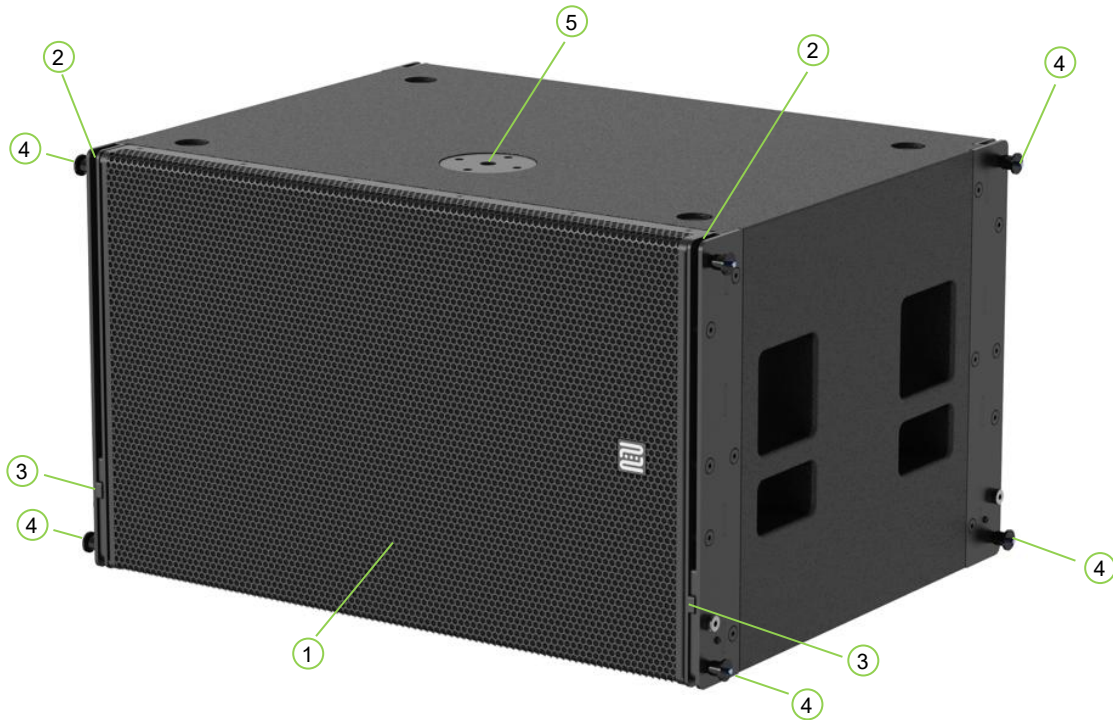

**No. Description of the**

- 1 XANA L-118 SA subwoofer
- 2 Connection opening for attaching the speaker to the connecting slide of the flying frame or the subwoofer above it
- 3 Connecting slide for mounting an L-118 SA subwoofer underneath
- 4 Socket pin with locking mechanism
- 5 M20 threaded sleeve

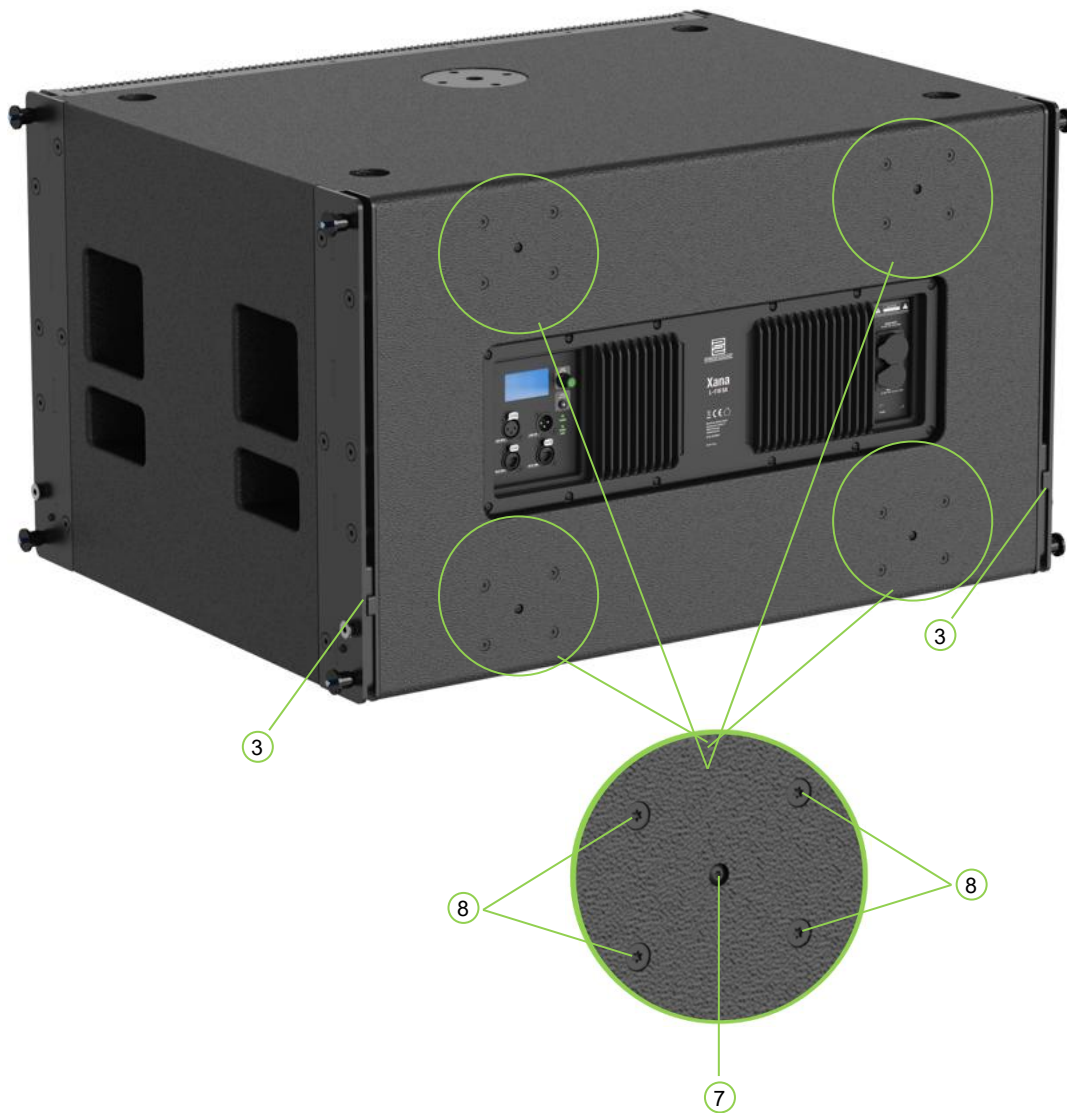

**No. Description of the**

- 7 Drive-in nut for fastening the rubber feet
- 8 M8 drive-in nuts for fastening transport rollers (hole size 80 mm x 60 mm)

## 3.2.2 Electronics

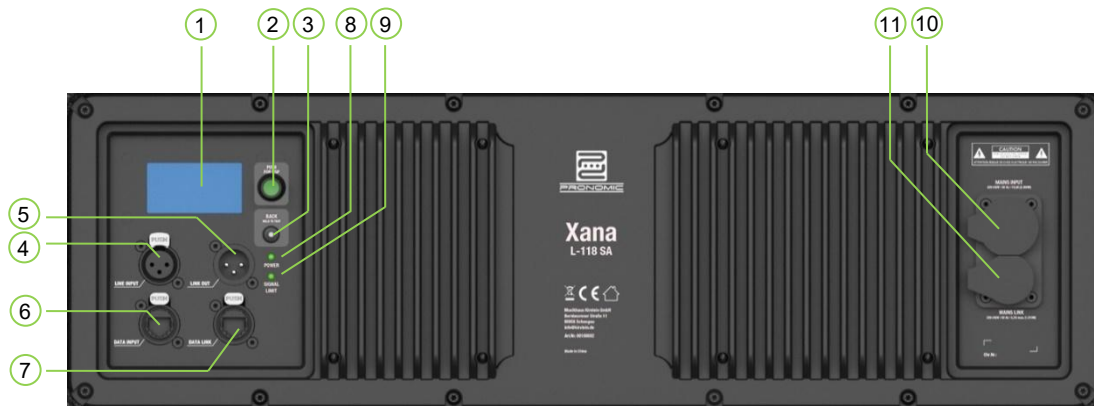

### No. Description of the

- 1 **LCD screen:** Provides access to speaker operating modes, DSP parameters, network settings and more
- 2 **PUSH FOR DSP:** Rotary control for parameter setting with push function to confirm the choice.
- 3 **BACK & HOLD TO TEST:** Button is used in conjunction with the rotary control to control the parameters displayed on the LCD screen.  
Short press = "back"  
Long press = (>5 sec.) starts a frequency sweep signal for speaker test
- 4 **LINE INPUT:** XLR input (balanced)  
The input signal is fed directly to the DSP.
- 5 **LINE OUT:** XLR output (balanced)  
The output receives the direct signal from the input and bypasses the DSP so that there is no latency. The output continues to function even in the event of a power failure.
- 6 **DATA INPUT:** etherCON network socket for controlling the parameters via RS485 protocol.
- 7 **DATA LINK:** etherCON network socket for connecting an additional device.
- 8 **POWER:** LED indicates whether the device is supplied with power.
- 9 **SIGNAL / LIMIT:** LED indicates whether a signal is present or whether the amplifier is being overdriven.
- 10 **MAINS INPUT:** Power connection input (powerCon True1 compatible)
- 11 **MAINS LINK:** Power connection output (powerCon True1 compatible) is used to supply power to other devices. ATTENTION: Do not exceed the max. power specifications.

## 3.3 Accessories

### 3.3.1 XANA L-208 TA Flying frame incl. flybar

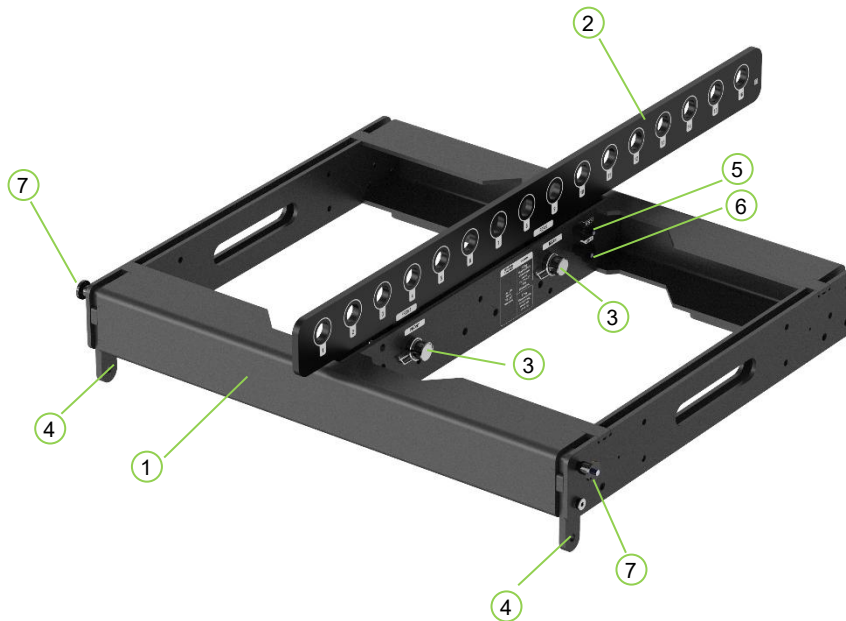

#### No. Description of the

- 1 The flying frame is designed to accommodate up to 16 flown XANA L-208 TAs
- 2 The flybar provides 16 possible hanging points (pick points). The diameter is 20 mm.
- 3 Connecting bolt between flying frame and flybar with safety pin
- 4 Front connecting slide for mounting an L-208 TA top unit
- 5 Rear connection point (LINK) for mounting the load bar of an L-208 TA top section
- 6 Rear connection point (LOCK) for fixing the position of the load bar of an L-208 TA top section
- 7 Socket pin with locking mechanism

The flybar can be used in both '**normal**' and '**inverse**' modes.

The '**normal**' mode is shown in the illustration. In this case, the '**FRONT**' marking on the flybar must be aligned with the '**FRONT**' marking on the airframe.

For "inverted" use, the flybar must be rotated by 180°. In this case, the "**FRONT**" marking on the flybar must be aligned with the "**REAR**" marking on the flying frame.

## 3.3.2 XANA L-118 SA flying frame incl. flybar

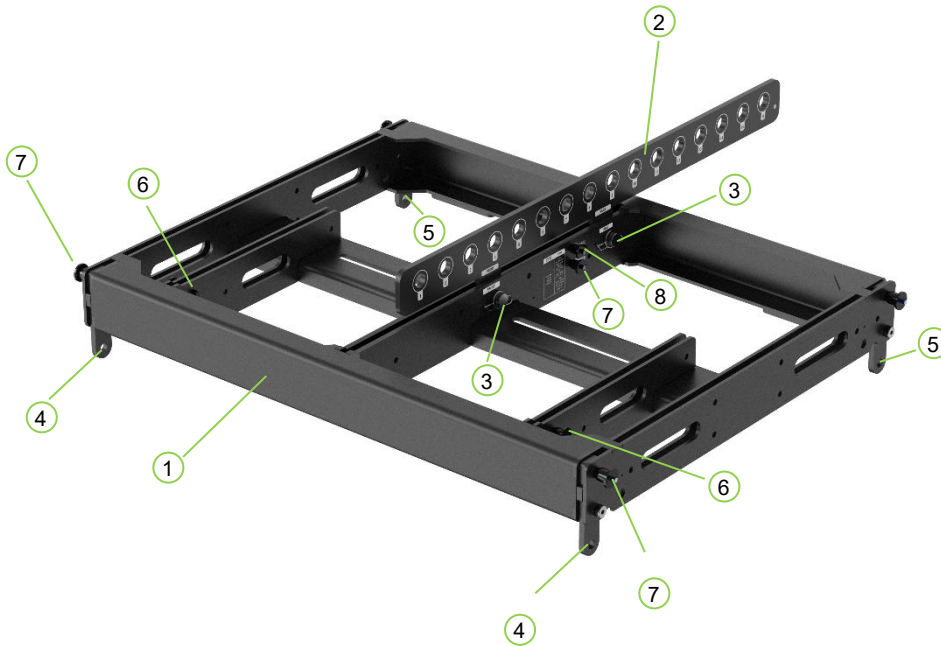

### No. Description of the

- 1 The flying frame is designed to accommodate up to 8 flown XANA L-118 subwoofers or 16 flown XANA L-208 subwoofers. Permitted combinations are also possible.
- 2 The flybar provides 16 possible hanging points (pick points). The diameter is 20 mm.
- 3 Connecting bolt between flying frame and flybar with safety pin
- 4 Front connecting slide for mounting an L-118 SA subwoofer
- 5 Rear connecting slide for mounting an L-118 SA subwoofer
- 6 Front connection point for mounting an L-208 TA top unit
- 7 Rear connection point (LINK) for mounting the load bar of an L-208 TA top section
- 8 Rear connection point (LOCK) for fixing the position of the load bar of an L-208 TA top section

The flybar can be used in both '**normal**' and '**inverse**' modes.

The '**normal**' mode is shown in the illustration. In this case, the '**FRONT**' marking on the flybar must be aligned with the '**FRONT**' marking on the airframe.

For "inverted" use, the flybar must be rotated by 180°. In this case, the "**FRONT**" marking on the flybar must be aligned with the "**REAR**" marking on the flying frame.

## 3.3.3 XANA L-208 TA Transport Dolly

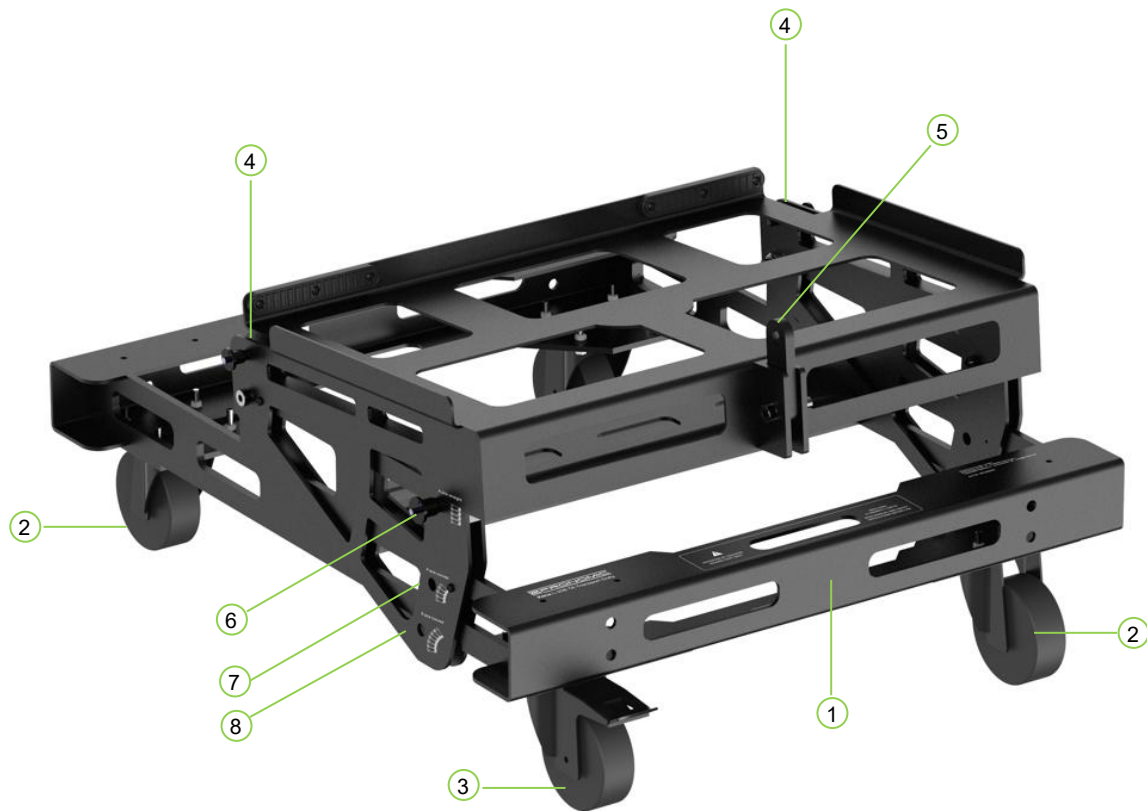

**No. Description of the**

- 1 The transport dolly is designed for convenient transport of up to 6 L-208 TA speakers
- 2 2 unbraked transport castors
- 3 2 braked transport castors
- 4 Connection opening for attaching the front connecting slide of the surface-mounted top section L-208 TA
- 5 Rear connection point for fixing the L-208 TA top in place via the LINK pin (similar to the load bracket of an L-208 TA top, only shortened)
- 6 "Straight" angle adjustment for upright mounting of up to 4 L-208 TA tops
- 7 Angle adjustment "4pcs curved" for angled mounting of up to 4 tops L-208TA
- 8 Angle adjustment "6pcs curved" for angled mounting of up to 6 tops L-208TA

### 3.3.4 XANA L-118 SA Transport Dolly

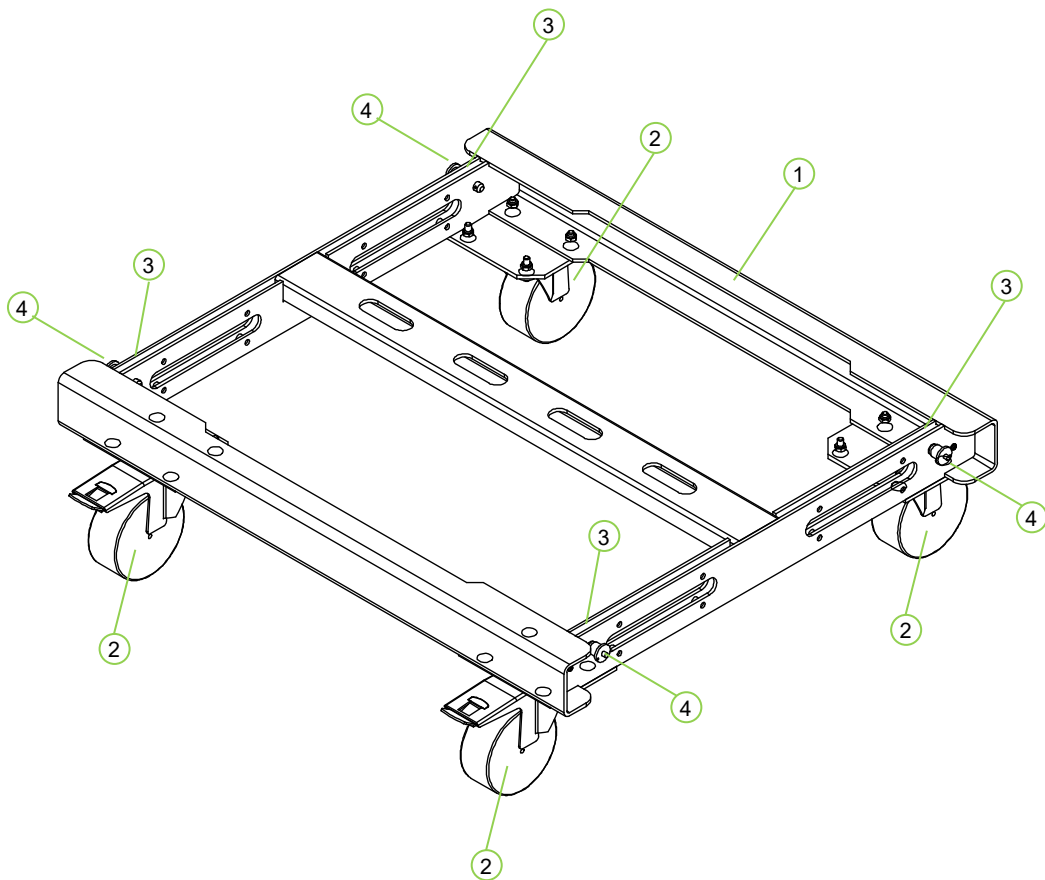
**Nr. Beschreibung**

- 1 The transport dolly is designed for convenient transport of up to 3 L-118 SA speakers
- 2 4 braked transport castors (125mm / 400kg load capacity)
- 3 Connection opening for attaching the speaker to the connecting slide of the flying frame or the subwoofer above it
- 4 Socket pin with locking mechanism

### 3.3.5 Other accessories

#### XANA Standbase für L-208TA Flugrahmen

For mounting the XANA L-208TA flying frame on the L-118SA subwoofer for use as a ground stack

Item no. 0011195

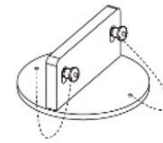

#### XANA Tilt Unit für L-208TA und L-118SA Flugrahmen

For connecting the XANA L-208TA speaker to the L-208TA and L-118SA flying frame. Angle settings from 0° to 10° possible.

Item no. 0011194

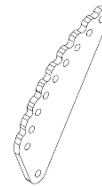

#### XANA L-208TA Schutzhülle für 4 Stück

Protective or transport cover for 4x XANA L-208TA speakers angled at 10° on the transport dolly.

Item no. 00108694



#### XANA L-208TA Schutzhülle für 6 Stück

Protective or transport cover for 6x XANA L-208TA speakers angled at 10° on the transport dolly.

Item no. 00108695



#### XANA L-118SA Schutzhülle

Protective and transport cover for XANA L-118SA subwoofer

Item no. 00108699

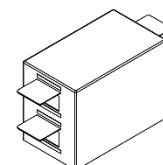

**XANA L-118SA Schutzhülle für 3 Stück**

Protective and transport cover for  
3x XANA L-118SA subwoofer on the dolly

Item no. 00108990

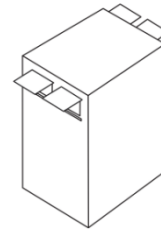

**XANA L-208 TA Regenschutz für Elektronik**

Metal frame with foldable fabric to protect  
the electronics

Item no. 00111201



**XANA L-118 SA Regenschutz für Elektronik**

Metal frame with foldable fabric to protect  
the electronics

Item no. 00111203



**Lenkrollen Satz 2x m.Bremse, 2x o.Bremse**

Castor set suitable for XANA L-118SA subwoofer  
hole size 80mm x 60mm / castor diameter 100mm

Item no. 00111805

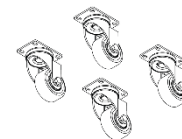

**Pronomic USB-RS485 Interface für P.sysManager**

USB interface with etherCon compatible network socket  
for controlling the XANA L-208TA and L-118SA speakers

Item no. 00108696



## 4 DSP settings

The LCD screen on the back provides a user-friendly interface for setting various devices, speaker and network parameters.

Navigation through the menus is via the **"PUSH FOR DSP" endless controller**:

- **Turn** the control to scroll through menus and options.
- **Press** the slider to start editing a selected parameter.
- **Turn** again to set the desired value and
- **Press** again to confirm the selected value.

Press the **"BACK" button** to return to the previous menu. If you are in a confirmation dialogue, you can cancel the process with the BACK button.

All settings on the appliance are retained even after a power failure.

### 4.1 XANA L-208 TA

#### 4.1.1 Start screen

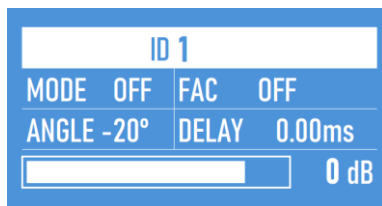

The start screen is displayed as soon as the device has completed the switch-on routine. Press the BACK button to return to the start screen from a submenu.

You can adjust the input sensitivity by turning the **Push For DSP** control.

Adjustable parameters: -80db to +12db

#### 4.1.2 Main menu

<b>HPF</b>	70Hz
ALC	OFF
FAC	OFF
MUTE	OFF
DELAY	0.00ms
TEST VOL	0dB
RESET	
INFO	0.05
ID	1
AOD	OFF

Pressing the **Push For DSP** control opens the main menu. You can access all submenus via the main menu.

The current menu position is highlighted in white. The white bar on the right-hand side indicates which area of the main menu you are in.

**4.1.3 Submenu**

HPF	70Hz
ALC	OFF
FAC	OFF
MUTE	OFF

**HPF** stands for High Pass Filter

Adjustable parameters: 70Hz - 120Hz

HPF	70Hz
ALC	4-6a
FAC	OFF
MUTE	OFF

**ALC** - Array Length Correction

Compensate the mid-range frequencies boost as the number of tops used increases

Adjustable parameters:

- 4 - 6a when using 4-6 tops
- 4 - 6b when using 4-6 tops
- 7 - 9a when using 7-9 tops
- 7 - 9b when using 7-9 tops
- 10 - 12 a when using 10-12 tops
- 10 - 12 b when using 10-12 tops
- 13+ a when using 13 or more L-208 TA
- 13+ b when using 13 or more L-208 TA
- 13+ c when using 13 or more L-208 TA

HPF	70Hz
ALC	OFF
FAC	1
MUTE	OFF

**FAC** - Field Ambience Correction

Compensate the high-range frequencies attenuation caused by increasing humidity and temperature

Adjustable parameters: 1 - 15

HPF	70Hz
ALC	OFF
FAC	OFF
MUTE	ON

**MUTE**

Mutes the input signal

Adjustable parameters: OFF / ON

DELAY	0.00ms
TEST VOL	0dB
RESET	
INFO	0.0.5

**DELAY**

Adjustable delay for runtime correction

Adjustable parameters: 0.00ms - 170.00ms

DELAY	0.00ms
TEST VOL	◀ 0dB
RESET	
INFO	0.0.5

**TEST VOL**

Adjustable volume of the loudspeaker test signals. The test signal is activated by pressing the BACK button for 5 seconds.

Adjustable parameters: 0dB to -18dB



**WARNING**

The test signal can be very loud and cause hearing damage

DELAY	0.00ms
TEST VOL	0dB
RESET	
INFO	0.0.5

**RESET**

Resets all parameters to factory settings.

Adjustable parameters: NO / YES

Security enquiry

**ARE YOU SURE?**

Return the device to its factory default condition

NO: back to the submenu  
 YES: Factory settings are loaded

DELAY	0.00ms
TEST VOL	0dB
RESET	
INFO	0.0.5

**INFO**

Firmware version of the device. Can be updated with the P.sys.MANAGER software.

RESET	
INFO	0.0.5
ID	1 ▶
AOD	OFF

**ID**

The identification number is used to assign the loudspeaker in the system. It must be set manually on the loudspeaker.

Adjustable parameters: 1 - 64

RESET	
INFO	0.05
ID	1
AOD	◀ 5Min ▶

## AOD

Auto Off Display switches the display off after the preset time

Adjustable parameters: OFF / 5 min. - 30 MIN.

## 4.2 XANA L-118 SA

### 4.2.1 Start screen

ID 2			
DELAY	0.00ms	ANGLE	0°
	NORMAL	HPF	30Hz
			0 dB

The start screen is displayed as soon as the device has completed the switch-on routine. Press the BACK button to return to the start screen from a submenu.

You can adjust the input sensitivity by turning the **Push For DSP** control.

Adjustable parameters: -80db to +12db

### 4.2.2 Main menu

LPF	40Hz
MODE	NORMAL
HPF	30Hz
MUTE	OFF
DELAY	0.00ms
POLARITY	0°
TEST VOL	0dB
RESET	
INFO	1.0.0
ID	2
AOD	OFF

Pressing the **Push For DSP** control opens the main menu. You can access all submenus via the main menu.

The current menu position is highlighted in white. The white bar on the right-hand side indicates which area of the main menu you are in.

### 4.2.3 Submenu

LPF	40Hz ▶
MODE	NORMAL
HPF	30Hz
MUTE	OFF

**LPF** stands for Low Pass Filter

Adjustable parameters: 40Hz - 120Hz

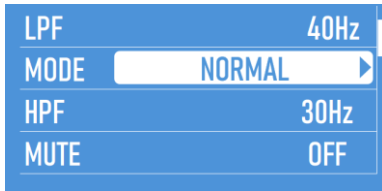

**MODE**

is used to set the cardioid function.

Adjustable modes: NORMAL  
CARDIOID FRONT  
CARDIOID REAR

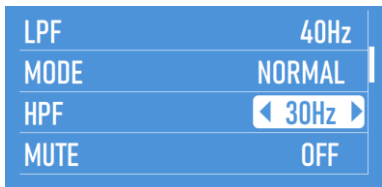

**HPF** stands for High Pass Filter

Adjustable parameters: 30Hz - 120Hz

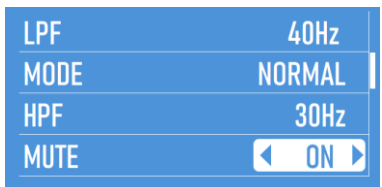

**MUTE**

Mutes the input signal

Adjustable parameters: OFF / ON

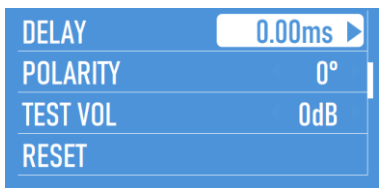

**DELAY**

Adjustable delay of the playback signal

Adjustable parameters: 0.00ms - 170.00ms

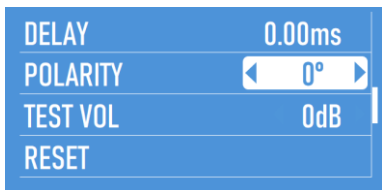

**POLARITY**

Adjustable phase position

Adjustable parameters: 0° and 180°

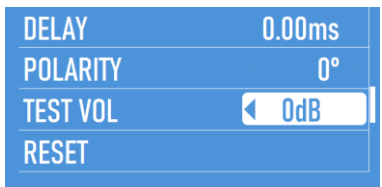

**TEST VOL**

Adjustable volume of the loudspeaker test signals. The test signal is activated by pressing the BACK button for 5 seconds.

Adjustable parameters: 0dB to -18dB



**WARNING**

The test signal can be very loud and cause hearing damage

DELAY	0.00ms
POLARITY	0°
TEST VOL	0dB
<b>RESET</b>	

**RESET**

Resets all parameters to factory settings.

Adjustable parameters: NO / YES

Security enquiry

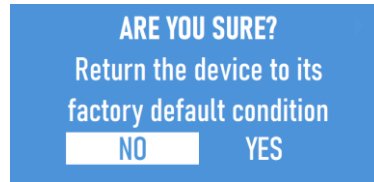

NO: back to the submenu

YES: Factory settings are loaded

<b>RESET</b>	
INFO	1.0.0
ID	2
AOD	OFF

**INFO**

Firmware version of the device. Can be updated with the P.sys.MANAGER software.

<b>RESET</b>	
INFO	1.0.0
ID	2
AOD	OFF

**ID**

The identification number is used to assign the loudspeaker in the system. It must be set manually on the loudspeaker.

Adjustable range: 1 - 64

<b>RESET</b>	
INFO	1.0.0
ID	2
AOD	5Min

**AOD**

Auto Off Display switches the display off after the preset time

Adjustable range: OFF / 5 min. - 30 MIN.

## 5 P.sysMANAGER - Software



The P.sysMANAGER software was specially designed to control the XANA line array systems and runs under Microsoft Windows® 10 or later .

The "Pronomic USB-RS485 Interface for P.sysManager" Art.No.00108696 is required for the connection between the computer and the loudspeakers.

The software gives you access to all the parameters of each individual speaker connected to the interface. Additional functions such as EQ, grouping etc. are also available.

For convenient system planning, the software also works offline (without connected devices) so that configurations can be saved as projects before installation.

You can download the software under the link: <https://www.kirstein.de/Xana>

## 6 EASE Focus 3 - Software

The EASE Focus 3 software is available for acoustic and mechanical simulation of the XANA line array system.

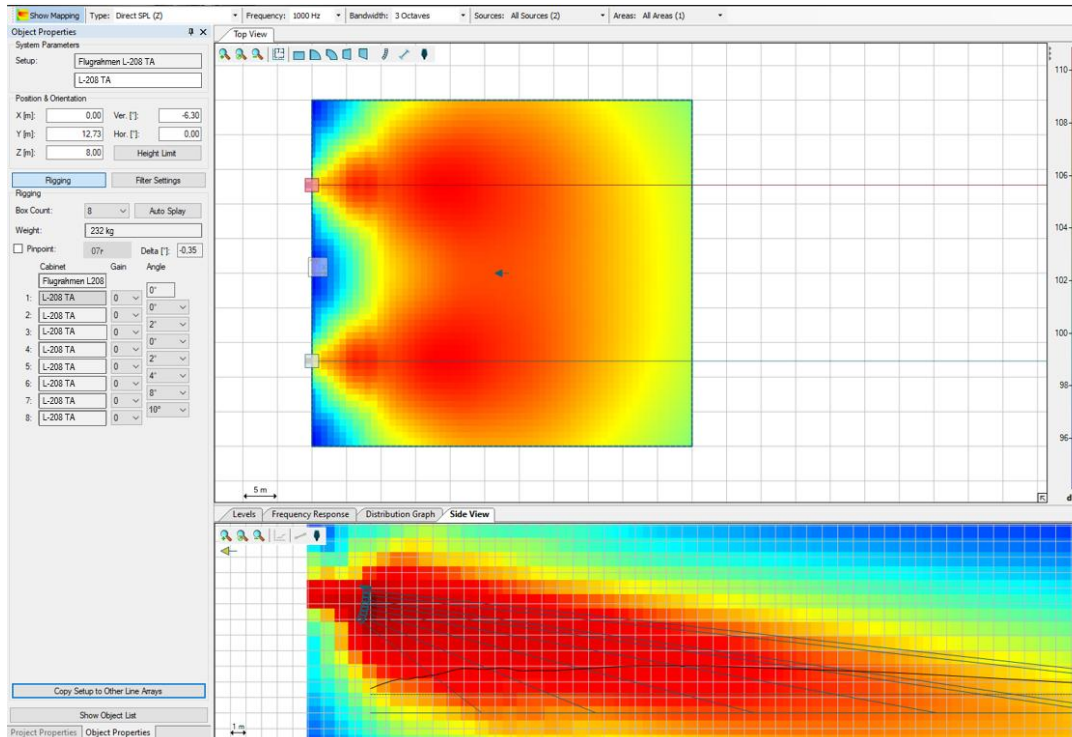

### Using EASE Focus 3

You can download the software free of charge from <https://www.afmg.eu/en/ease-focus>. The software can be used to easily determine how the XANA line array speakers need to be tilted and angled in order to achieve optimum sound distribution in the audience area. Please observe all warnings displayed during use and always check the plausibility of the simulation results.

You can download the XANA simulation data for use in EASE Focus via the following link: <https://www.kirstein.de/Xana>



If the software issues a warning, the system is mechanically overloaded. The system must not be flown in this configuration under any circumstances. In such a case, adjust the configuration so that the warning disappears.

## Optimum alignment of the line array system

Use the "Auto-Splay function" of the software to determine the required angle settings. The lowest unit of the array should be just above the head height of the people standing on the stage. This allows the entire system to be operated with only slight angles between the individual elements - a decisive advantage for acoustic coupling (cylindrical wave principle).



### Important notes on security and system configuration

Also pay attention to the permissible loads listed in the following **section 7 "Load limits"**. Even minor deviations in the overall inclination or angle configuration can significantly affect both, the physical load limits and the acoustic result.

## 7 Load limits

The products and accessories in the XANA Line Array series have been designed in accordance with the guidelines of DGUV regulation 17 (BGV-C1) with a minimum breakage safety factor of 1:3.75.

Up to 16 L-208TA tops can be flown on the XANA L-208TA Flying Frame. The XANA L-118SA Flying Frame allows up to 8 L-118SA subwoofers or a combination of 2x L-118SA subwoofers and a maximum of 12x L-208TA tops to be flown.

However, the actual number of units permitted depends on the downtilt of the array and the pickpoint used. The downtilt itself depends on:

- the length of the array
- the position of the pickpoint and
- the angulation of the individual XANA elements.

As the Flying Frame is always connected to the uppermost top section or subwoofer at an angle of 0°, the inclination of the frame automatically corresponds to the inclination of the uppermost element. **Note:** For a 0° alignment of the uppermost top section L-208TA on the flying frame, the LINK pin must be set at 2°.

## Important note on planning

Before installation, it is recommended to simulate the desired system configuration using the EASE Focus 3 software.

The maximum possible loads can be found in the table below. If the software nevertheless issues a warning, the system is mechanically overloaded. The system must not be flown in this configuration under any circumstances. In such a case, adjust the configuration so that the warning disappears.

### 7.1 XANA L-208 TA flying frame incl. flybar

Load specifications apply to the flybar in the **'normal'** and **'invers'** positions

Hanging point (pick point)	Max. permissible number Tops L-208 TA
<b>1 - 12</b>	16
<b>13</b>	15
<b>14</b>	14
<b>15</b>	12
<b>16</b>	10

## 7.2 XANA L-118 SA flying frame incl. flybar

### 7.2.1 Flybar in position “normal”

Hanging point (pick point)	Max. permissible number Tops L-208 TA	Max. permissible number Subwoofer L-118 SA	Max. permissible combination of 2x subwoofers L-118 SA + number of L-208 TA tops
1	9	3	+ 3
2	15	4	+ 4
3	16	5	+ 6
4	16	5	+ 8
5	16	8	+ 12
6	16	8	+ 12
7	16	8	+ 12
8	16	8	+ 12
9	16	8	+ 12
10	15	8	+ 12
11	14	8	+ 12
12	13	8	+ 12
13	12	6	+ 11
14	12	5	+ 7
15	10	4	+ 4
16	6	3	+ 3

**7.2.2 Flybar in position "invers"**

Hängepunkt (Pickpoint)	Max. zulässige Anzahl Topteile L-208 TA	Max. zulässige Anzahl Subwoofer L-118 SA	Max. zulässige Kombination aus 2x Subwoofer L-118 SA + Anzahl Topteile L-208 TA
1	10	3	+ 3
2	11	4	+ 4
3	12	6	+ 6
4	14	5	+ 8
5	15	8	+ 12
6	16	8	+ 12
7	16	8	+ 12
8	16	8	+ 12
9	16	8	+ 12
10	16	8	+ 12
11	16	8	+ 12
12	16	8	+ 12
13	15	6	+ 11
14	14	5	+ 7
15	11	4	+ 4
16	10	3	+ 3

## 8 Assembly

### 8.1 Connections

#### 8.1.1 Locking pin with locking mechanism

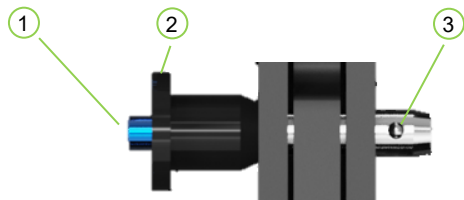

No.	Description of the
-----	--------------------

- |   |               |
|---|---------------|
| 1 | Spring button |
| 2 | Retaining rim |
| 3 | Locking       |

Press and hold the spring button during the insertion process. As soon as the bolt is fully inserted, release the spring button. Make sure that it then pops out again completely and the plug-in bolt is locked in place.



#### WARNING

Do not use force! If handled correctly, all connection points are easy to move!

Never plug or unplug connections under load.

Always ensure that all the connection points described have been established and securely connected.

### 8.1.2 Connecting bolt with safety split pin

There is a groove in the centre of the flying frame (1.) into which the flybar (2.) must be inserted. Make sure that the "FRONT" marking on the flybar points to the "FRONT" marking on the flying frame. Insert the flybar (2.) so deeply into the flying frame (1.) that the two connection openings (3.) are parallel to each other. Now insert the connecting bolt (4.) through the connecting opening (3.). Then secure the connecting bolt (4.) with the safety split pin (5.) to prevent it from falling out.

Proceed with the "REAR" connection in the same way as the "FRONT" connection

The flybar can also be used 'inversely'. In some situations, the flybar needs to be rotated by 180° (mounted inversely). In this case, the 'FRONT' marking on the flybar points towards the 'REAR' of the airframe.

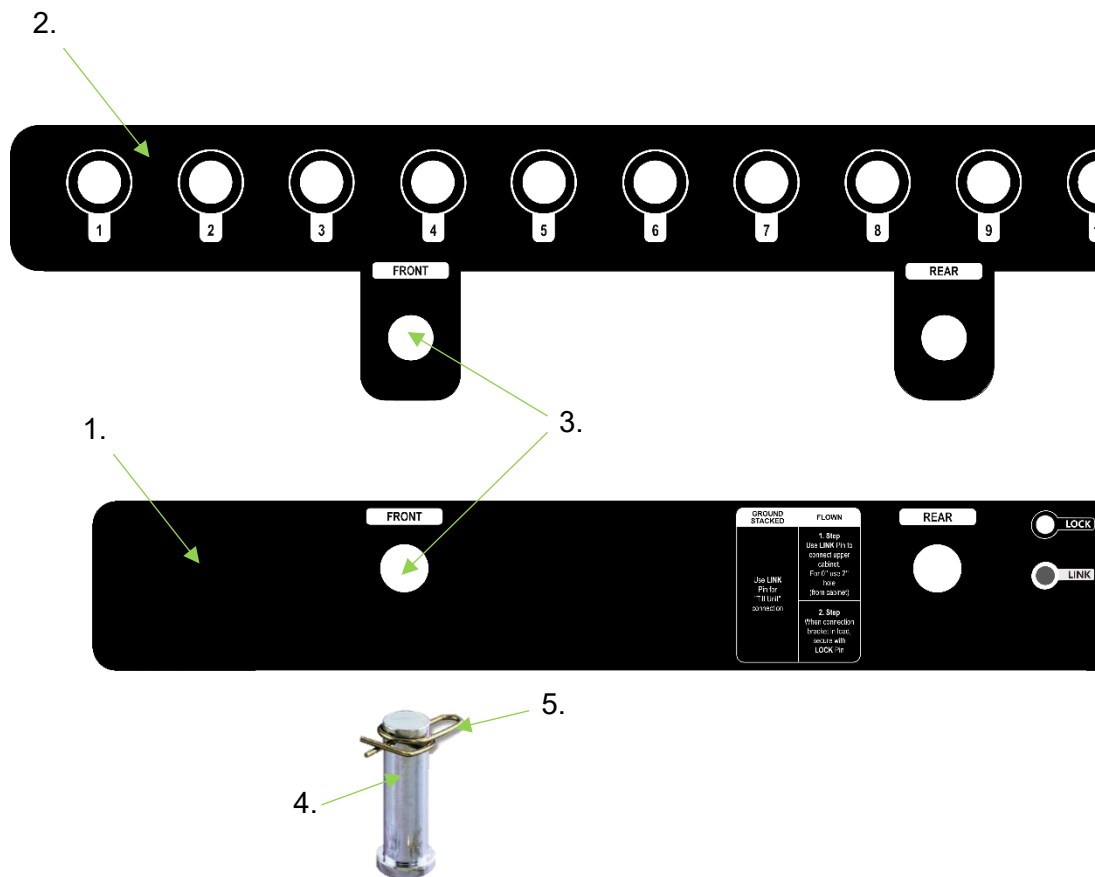

Check that the connecting bolts and safety cotter pins are correctly and securely seated before each use!

**8.2 Transport dolly**

**8.2.1 Adjusting the base plate**

First decide how many tops you want to transport on the dolly. You have the option of stacking either 4 or 6 elements.

There are two tilt positions for the base plate

To adjust the tilt, remove the two pins on the long side of the dolly. Tilt the base plate to the desired position using the illustrations and fix the plug pin in the corresponding hole.

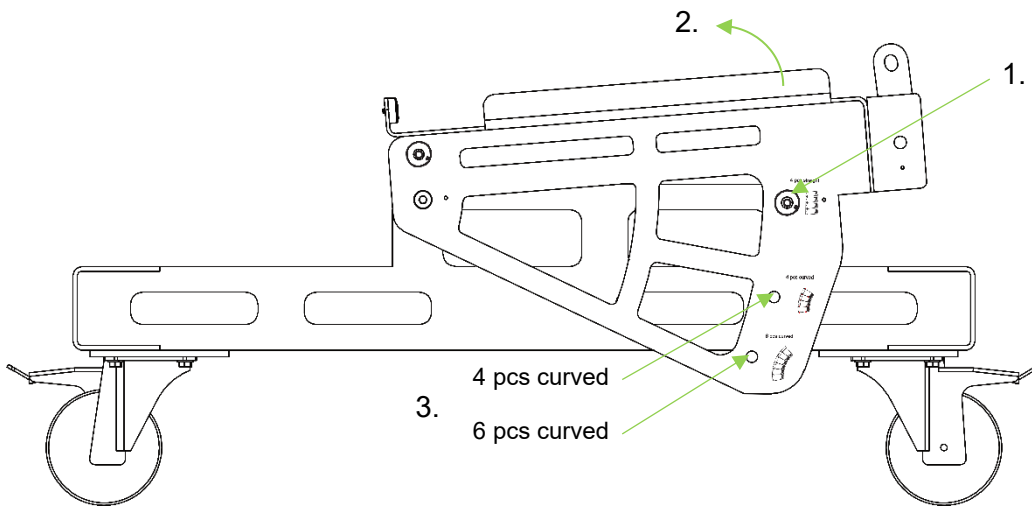

4 pcs curved

6 pcs curved

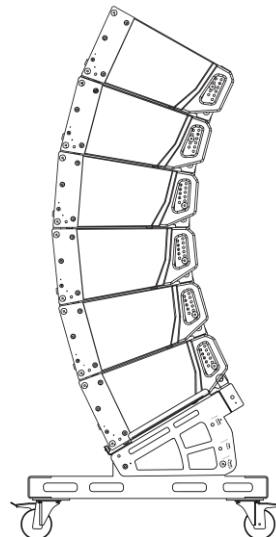
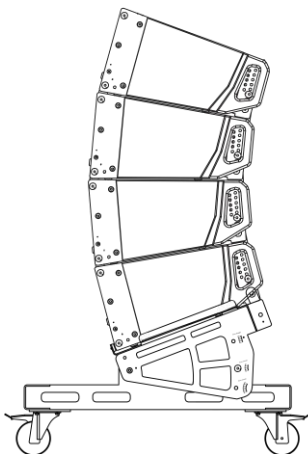

Info: There is a third position for stacking the tops with a fixed 0° angle. To do this, please follow the steps in the "Ground stack" section

### 8.2.2 Fixing the top section to the base plate

- Lift the first top section (1.) flush with the front grille onto the base plate and remove the two plug-in bolts (2.) at the front end of the base plate.
- Then remove the front plug-in bolts of the top section (3.), causing the connecting slide (4.) to slide downwards out of the housing. Secure the slide directly with these plug-in bolts (3.) in the same plug-in position.
- Then make the connection with the hole in the connecting slide by inserting the pins (2.) of the base plate back into position.
- Remove the LINK pin (5.) on the back of the top section. You can then fold the rear hinged bracket of the base plate (6.) upwards and secure it to the top section (5.) using the LINK pin.

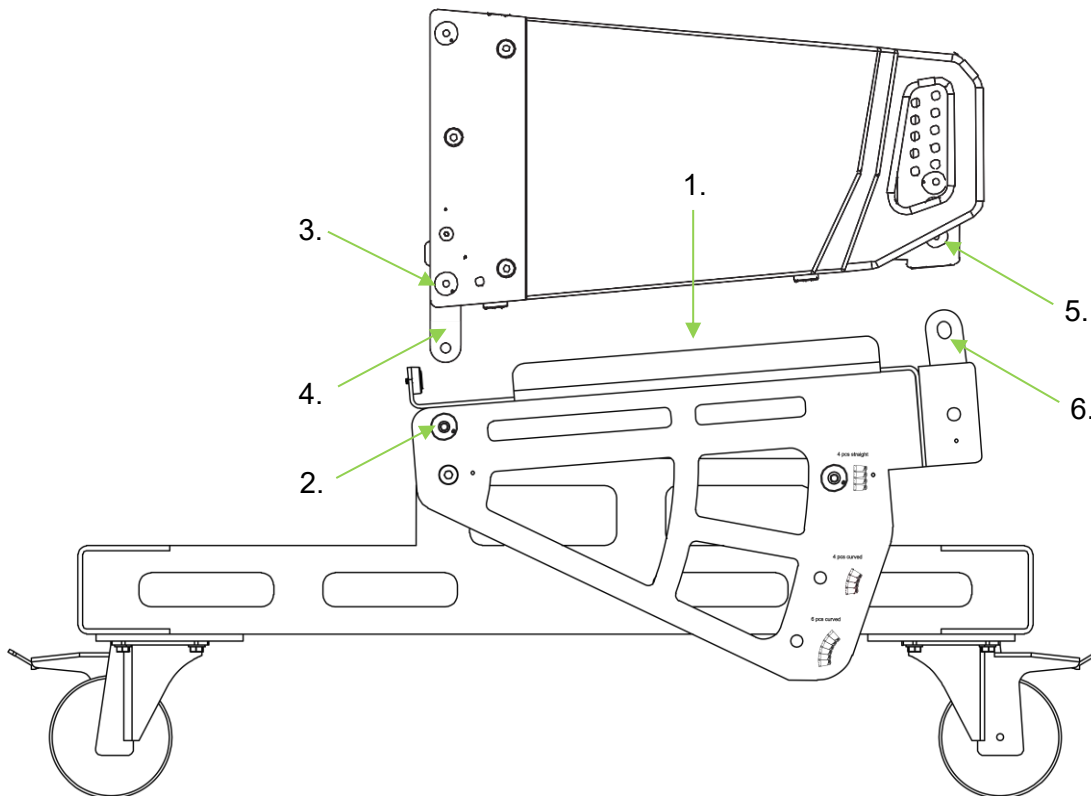

### 8.2.3 Fixing top section to top section

- Lift the next top section flush with the front grille onto the previous top section so that the rubber feet engage in the recesses (1.).
- Then remove the front plug-in bolts (3.) of the top section, allowing the connecting slide (4.) to slide downwards out of the housing. Secure the connecting slide directly with these plug-in bolts (3.) in the same plug-in position.
- Then make the connection with the hole in the connecting slide by inserting the rear pins (5.) of the top section into the holes on the top of the top section underneath (6.), where the ends of the connecting slides are also inserted.
- Remove the LINK pin (7.) on the back of the top section. Now push the load bar (8.) of the lower top section upwards until it touches the LOCK pin (9.) of the upper top section.
- The load bracket can be fixed in this position with the LINK pin (7.).
- Repeat this step according to the number of top sections set.

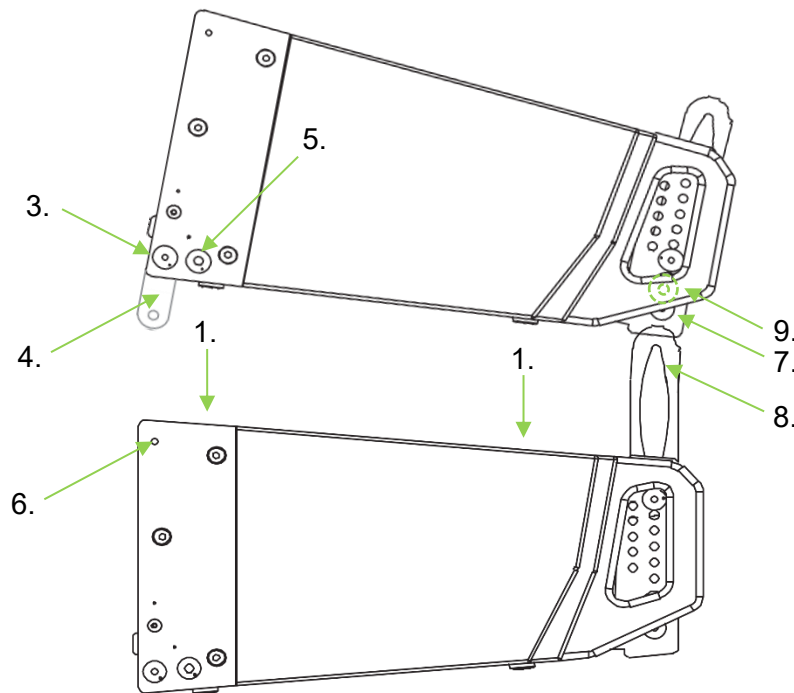

### 8.3 Ground stack

#### 8.3.1 Fixing subwoofer to subwoofer

- Lift the subwoofer flush with the front grille onto the lower subwoofer so that the rubber feet (1.) engage in the recesses. Two people are required for this.
- Remove the lower four plug-in bolts of the upper subwoofer (3.), the connecting slide (4.) will slide downwards out of the housing. Secure the connecting slide (4.) directly in the upper holes of the lower subwoofer (2.) using the same plug-in bolts (3.).
- Repeat this step for several subwoofers if necessary.

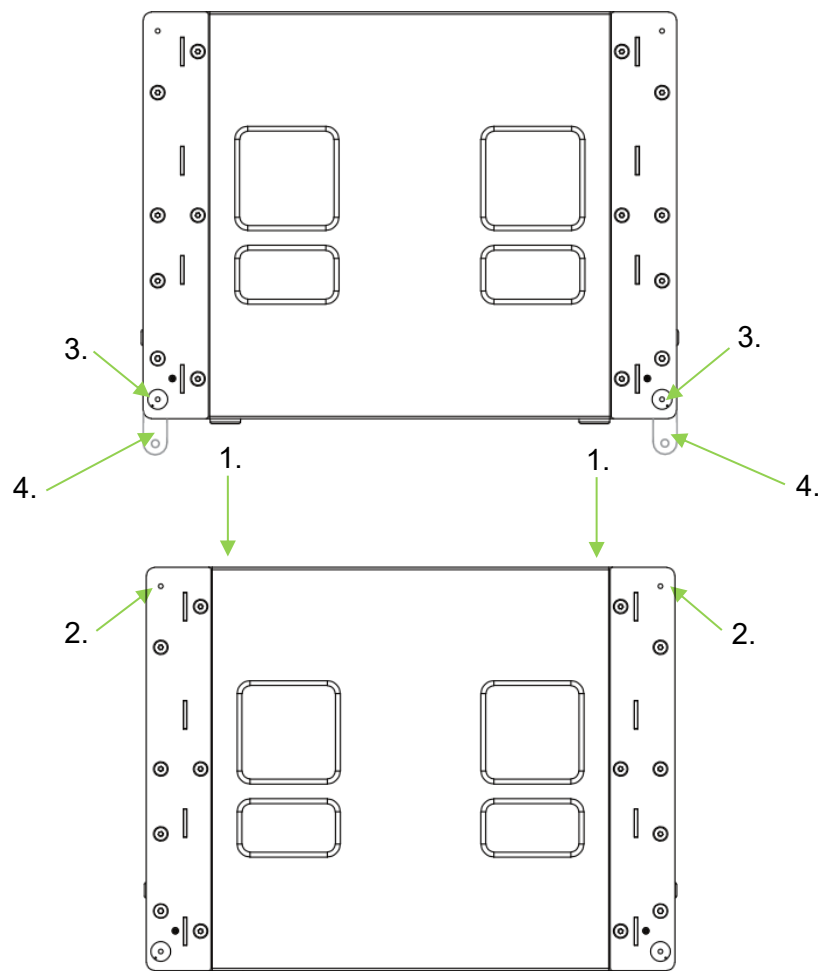

### 8.3.2 Flying frame on subwoofer

#### 8.3.2.1 Using the Xana L-118 SA flying frame

- Remove the four lower pins (1.) at the corners of the flying frame. The connecting slides (4.) with slotted hole fold out of the frame. Then push the socket pins (1.) back into their parking position.
- Remove the upper plug pin (2.) at each corner and slide the connecting slide along the slotted hole towards the position where the upper plug pin (2.) was and fix the slide there.
- Lift the flying frame flush with the outer edges onto the subwoofer. Use the labelling to ensure the correct orientation (top/bottom; front/rear). The instructions are located on the back of the frame.
- Then fix the flying frame to the subwoofer by inserting the parked lower four plug-in bolts (1.) of the flying frame into the upper four holes of the flying frame (5.) (through the connecting slide).

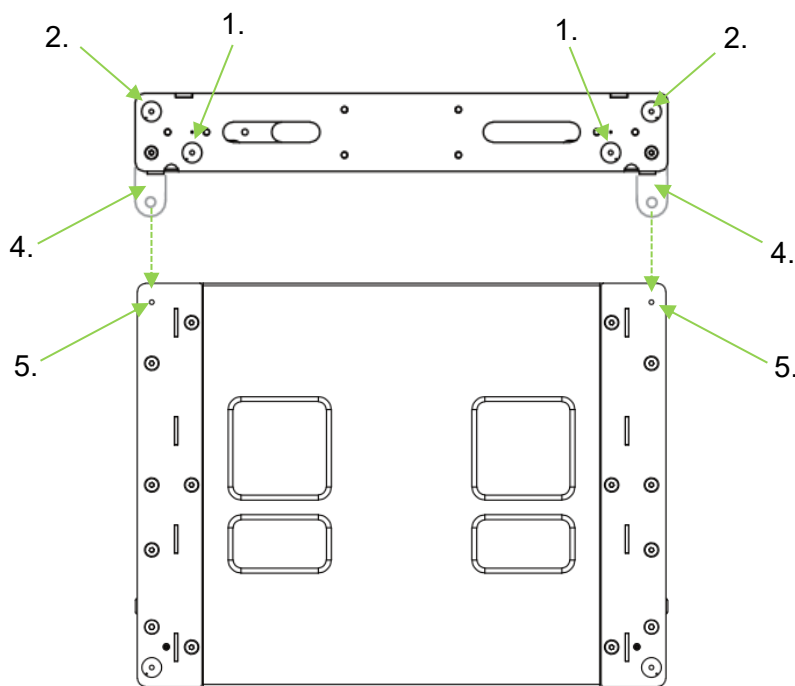

### 8.3.2.2 Using the Xana L-208 SA flying frame with standbase

- Screw the standbase (1.) (accessory item XANA standbase for L-208TA flying frame art. no. 0011195) into the M20 thread (2.) of the upper subwoofer and open the two plug-in bolts of the standbase (5.).
- Lift the flying frame (3.) onto the subwoofer, so that the steel plate of the standbase is in the centre of the flying frame in the gap between the two centre struts (4.). Use the labelling to ensure the correct alignment (top/bottom; front/rear). The connecting slides of the flying frame remain in the park position.
- Move the flying frame back and forth on the subwoofer until the hole pattern in the flying frame matches the hole pattern in the standbase. Now secure the flying frame to the standbase using the two plug-in bolts (5.).

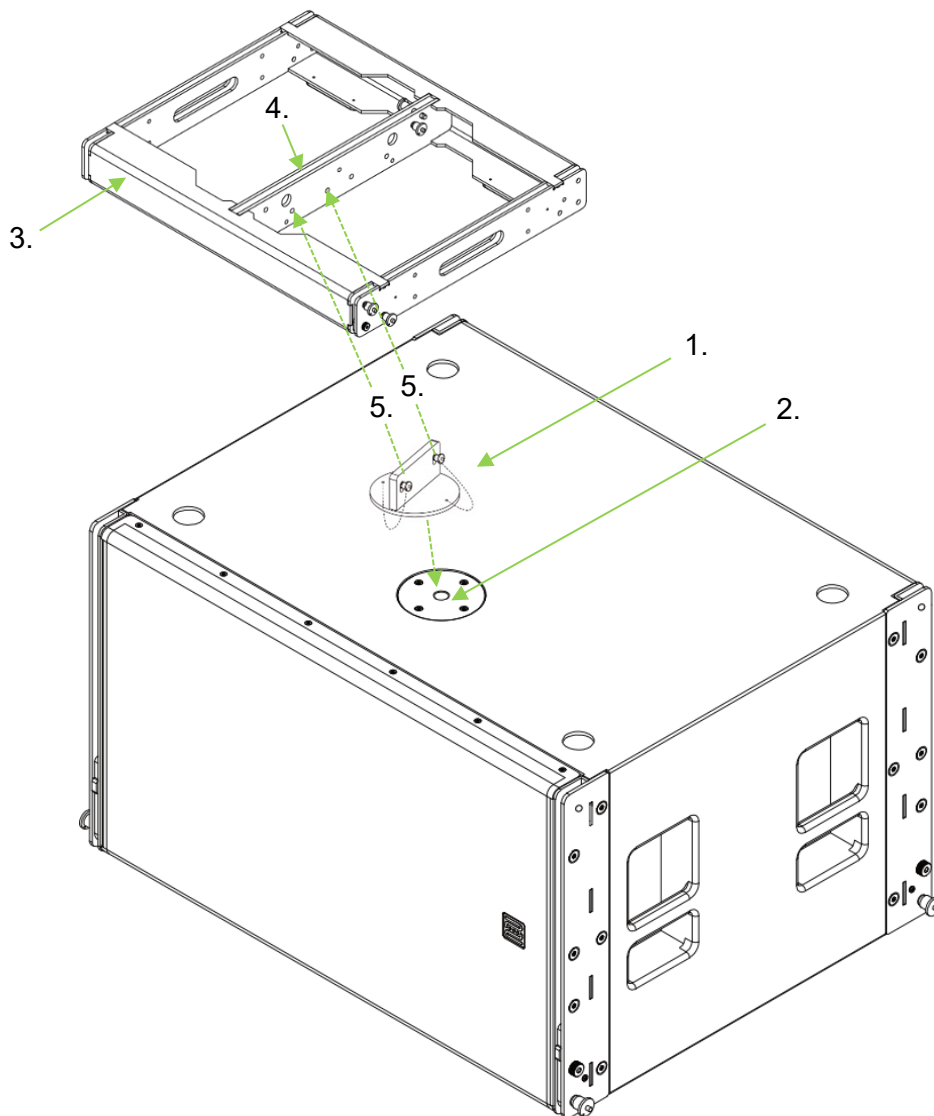

### 8.3.3 Fixing the top section to the flying frame

- Insert the tilt unit (1.) (accessory item no. 0011194) at the position of the LINK pin (2.) so that the toothed side is facing the front.
- Lift the first top flush with the front grille onto the flying frame.
- Remove the two front pins (3.) on the flying frame.
- Then remove the front plug-in bolts of the top section (4.), causing the connecting slide (5.) to slide downwards out of the housing. Then secure the connecting slide again directly with the plug-in bolts (4.) in the same plug-in position.
- Now connect the top section to the flying frame by pushing the front plug-in bolts (3.) of the flying frame back into position.
- Now remove the LINK pin (6.) on the back of the top section. Fold the tilt unit (1.) upwards and connect the tilt unit to the top section by inserting the LINK pin through the hole with the desired angle.

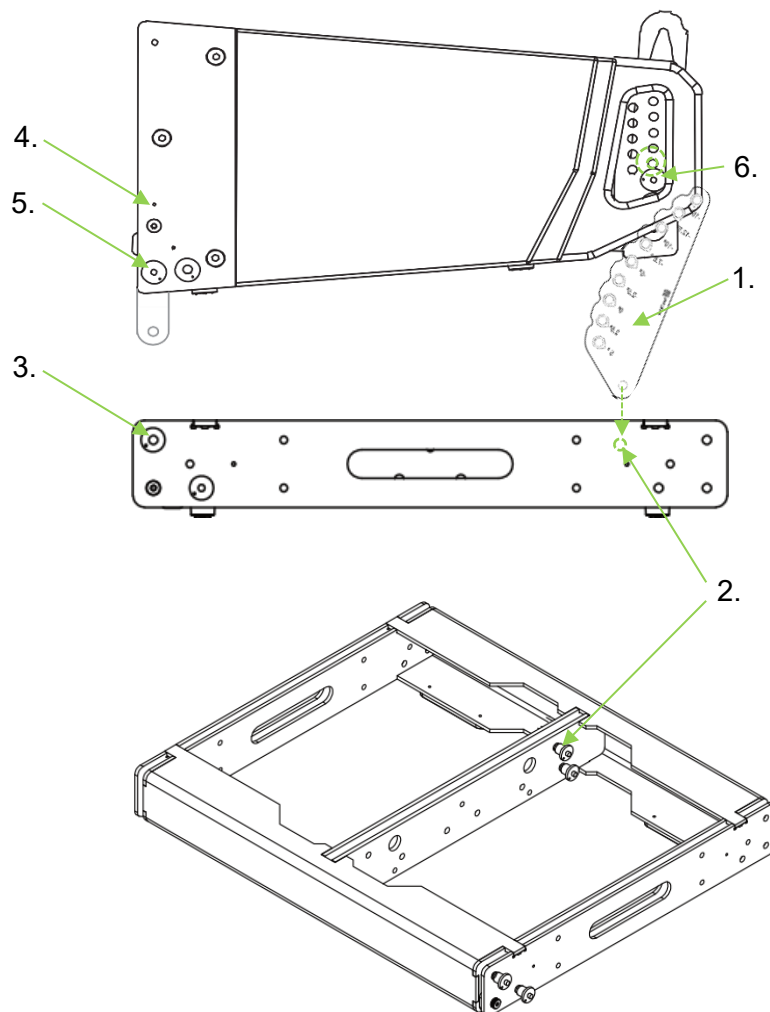

### 8.3.4 Fixing the top section to the top section

- Lift the next top section flush with the front grille onto the previous top section so that the rubber feet engage in the recesses (1.).
- Then remove the front plug-in bolts (3.) of the top section, allowing the connecting slide (4.) to slide downwards out of the housing. Secure the connecting slide directly with these plug-in bolts (3.) in the same plug-in position.
- Then make the connection with the hole in the connecting slide by inserting the rear plug pins (5.) of the top section into the holes on the top of the top section below (6.), where the ends of the connecting slides are also inserted.
- Remove the LINK pin (7.) on the back of the top section. Now push the load bar (8.) of the lower top section upwards, until it touches the LOCK pin (9.) of the upper top section.
- To set the desired angle, lift the top section sideways by the handles until the groove in the load bracket matches the desired angle on the scale on the right-hand side of the mounting rail.
- Then insert the connecting pin (10.) from the left-hand side of the mounting rail through the hole with the desired angle
- Repeat this step according to the number of top sections set.

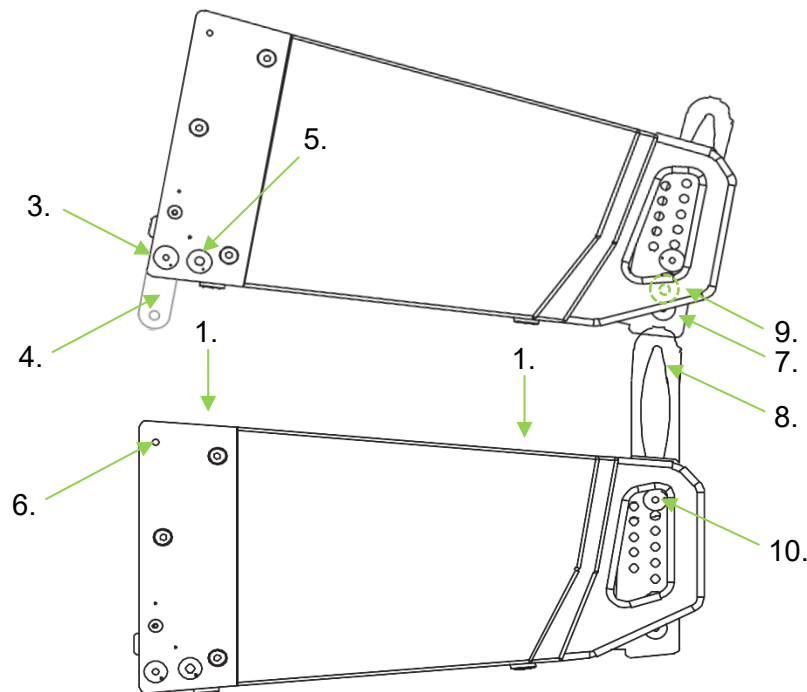

## 8.4 Flown system without subwoofer

### 8.4.1 Fixing the flying frame to top sections with transport dolly

- Remove the two lower pins (1.) on the left and right at the front corners of the flying frame. The connecting slides (2.) with slotted hole fold out of the frame. Then push the locking pins (1.) back into their park position.
- Remove the upper plug pin (3.) at the front corners. Slide the connecting slide along the slotted hole towards the position where the upper plug pin (3.) was and fix the slide there.
- Now lift the flying frame with these connecting slides flush to the front into the corresponding grooves of the top section (4.)
- Fix the connecting slides (2.) through the upper holes on the front of the top section (4.) with the lower plug-in bolts (1.) of the flying frame.
- Remove the rear LINK pin (5.) of the flying frame
- Now push the load bar (6.) of the uppermost top section upwards until it touches the LOCK pin (7.) of the flying frame.
- The load bracket (6.) can be fixed in this position with the LINK pin (5.).
- Now remove the LOCK pins (8.) from all top units on the transport dolly. The LINK pins (10.) always remain inserted.
- To set the desired angle, remove the angle pin (9.) from the top section underneath and slide the load bracket (6.) upwards, until the groove in the load bracket matches the desired angle on the scale on the right-hand side of the mounting rail
- Then insert the angle pin (9.) from the left-hand side of the mounting rail through the hole with the desired angle
- Repeat this step accordingly with the next top sections.

#### NOTE

To connect the uppermost top section to the flying frame, set ALWAYS set 2° to achieve a 0° angle. Follow the instructions on the flying frame!

- Now remove the three plug-in bolts (11.) that secure the top sections on the transport dolly.
- You can now lift the tops out of the dolly. This will automatically create the set angles.
- As soon as the array is under load, put all the LOCK pins (8.) back into position to lock the brackets in place.

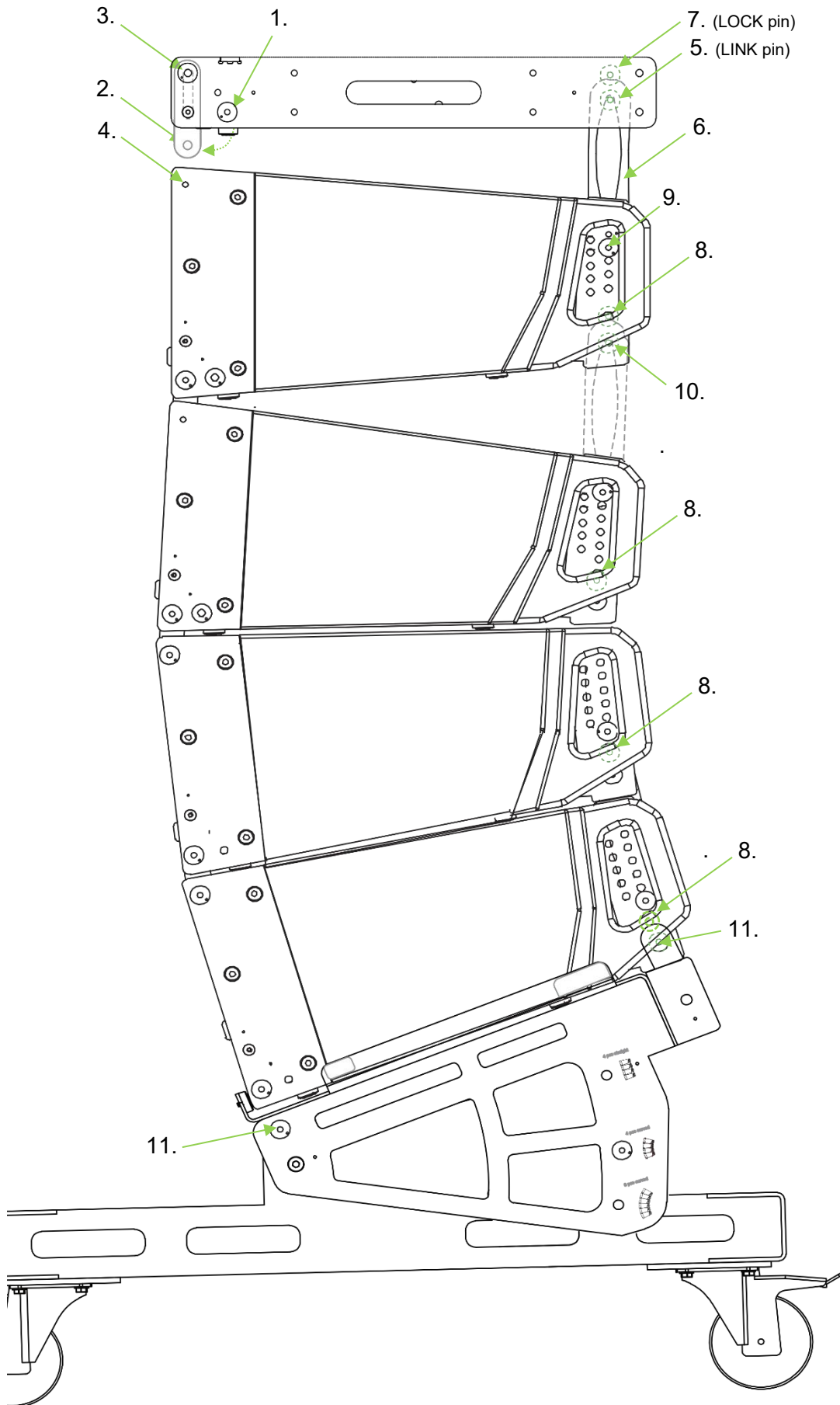

#### 8.4.2 Fixing flying top section on top section with transport dolly

- Remove the front plug-in bolts (1.) from the bottom top section of the array. The connecting slide (2.) will slide downwards out of the housing. Secure the slide directly with the plug-in bolts (1.) in the same plug-in position.
- Now lift the array with these connecting slides flush to the front into the corresponding grooves of the top section of the next transport dolly.
- Then make the connection with the hole in the connecting slide by inserting the rear pins (3.) of the lowest suspended top section into the holes (4.) on the top of the top section below, where the ends of the connecting slides (2.) are also inserted.
- Remove the LINK pin (5.) of the lowest suspended top section
- Now push the load bar (6.) of the topmost top section on the transport dolly upwards until it touches the LOCK pin (7.) of the lowest suspended top section.
- The load bracket (6.) can be fixed in this position with the link pin (5.).
- Now remove the LOCK pins (8.) from all tops on the transport dolly. The LINK pins always remain inserted.
- To set the desired angle, remove the angle pin (9.) from the top section underneath and slide the load bracket (10.) upwards, until the groove in the load bracket matches the desired angle on the scale on the right-hand side of the mounting rail (for details, see chapter 3.1.1)
- Then insert the angle pin (11.) from the left-hand side of the mounting rail through the hole with the desired angle
- Repeat this step accordingly with the next top sections.
- Now remove the three pins (12.) that secure the top sections on the transport dolly.
- You can now lift the tops out of the dolly. This will automatically create the set angles.
- As soon as the array is under load, put all LOCK pins (8.) back into position to lock the brackets.

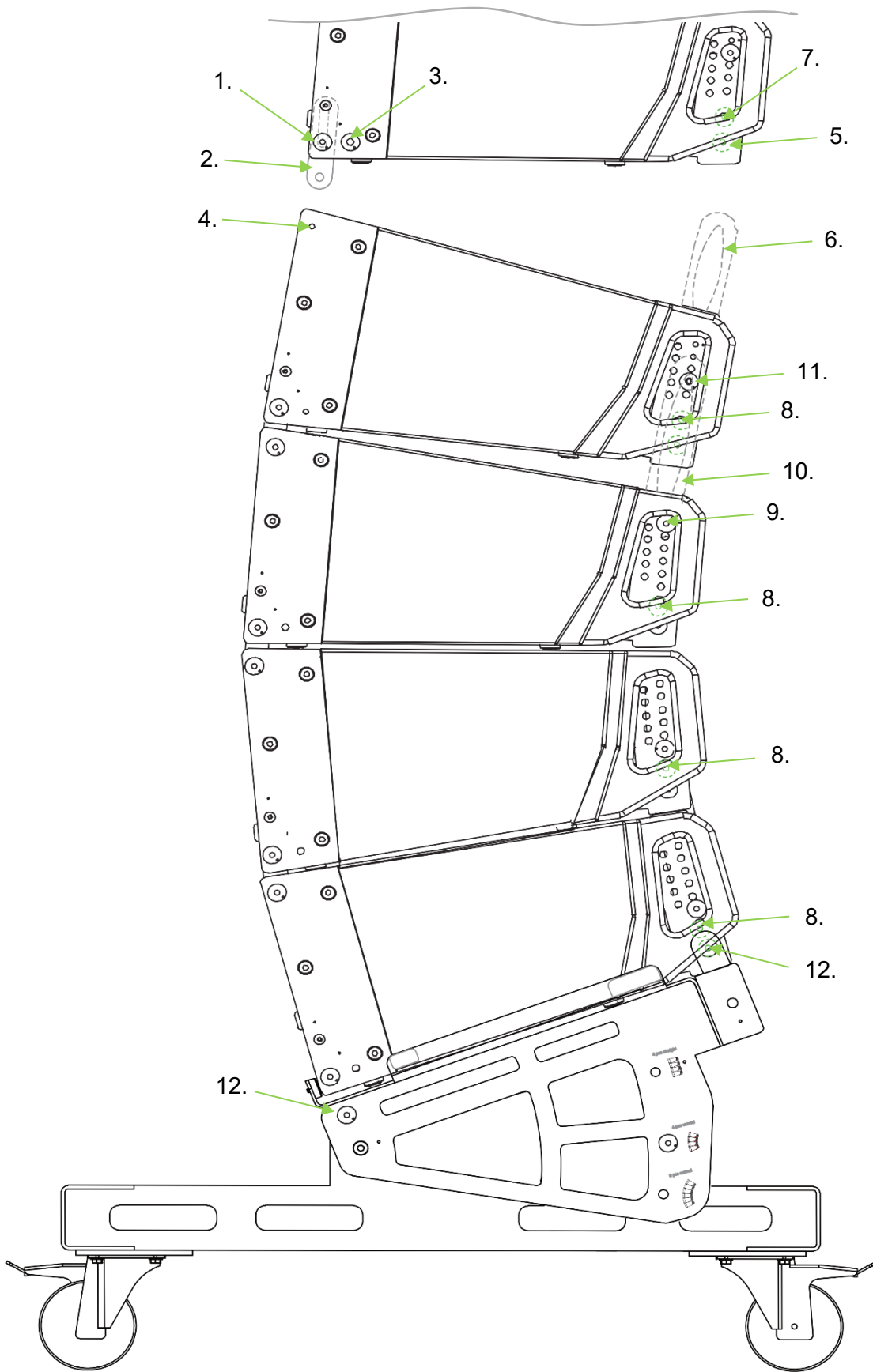

## 8.5 Flown system with subwoofer

### 8.5.1 Fixing the L-118 SA flying frame to the subwoofer

- Remove the four lower pins (1.) at the corners of the flying frame. The connecting slides (4.) with slotted hole fold out of the frame. Then push the socket pins (1.) back into their parking position.
- Remove the upper plug pin (2.) at each corner and slide the connecting slide along the slotted hole towards the position where the upper plug pin (2.) was and fix the slide there.
- Lift the flying frame flush with the outer edges onto the subwoofer. Use the labelling to ensure the correct orientation (top/bottom; front/rear). The instructions are located on the back of the frame.
- Then fix the flying frame to the subwoofer by inserting the parked lower four plug-in bolts (1.) of the flying frame into the upper four holes of the flying frame (5.) (through the connecting slide).

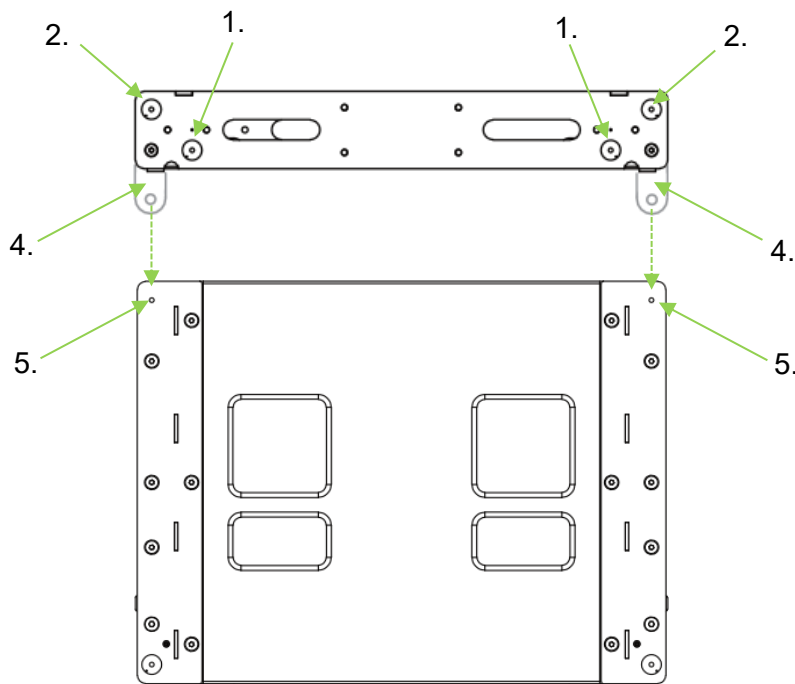

### 8.5.2 Fixing the L-118 SA flying frame under the subwoofer

- Lift the subwoofer(s) flush with the front grille onto the flying frame. Two people or suitable lifting gear are required for this. Use the labelling to ensure the correct orientation (top/bottom; front/rear). The connecting slides (1.) of the flying frame remain in the park position.
- Remove the four upper pins (2.) at the corners of the flying frame.
- Then remove the lower four plug-in bolts (3.) of the subwoofer on the flying frame. The connecting slide (4.) will slide downwards out of the housing. Then push the plug-in bolt (3.) back into its original position.
- Then make the connection with the hole in the connecting slide by inserting the upper pins (2.) of the flying frame back into their position, where the ends of the connecting slides (4.) are also inserted.

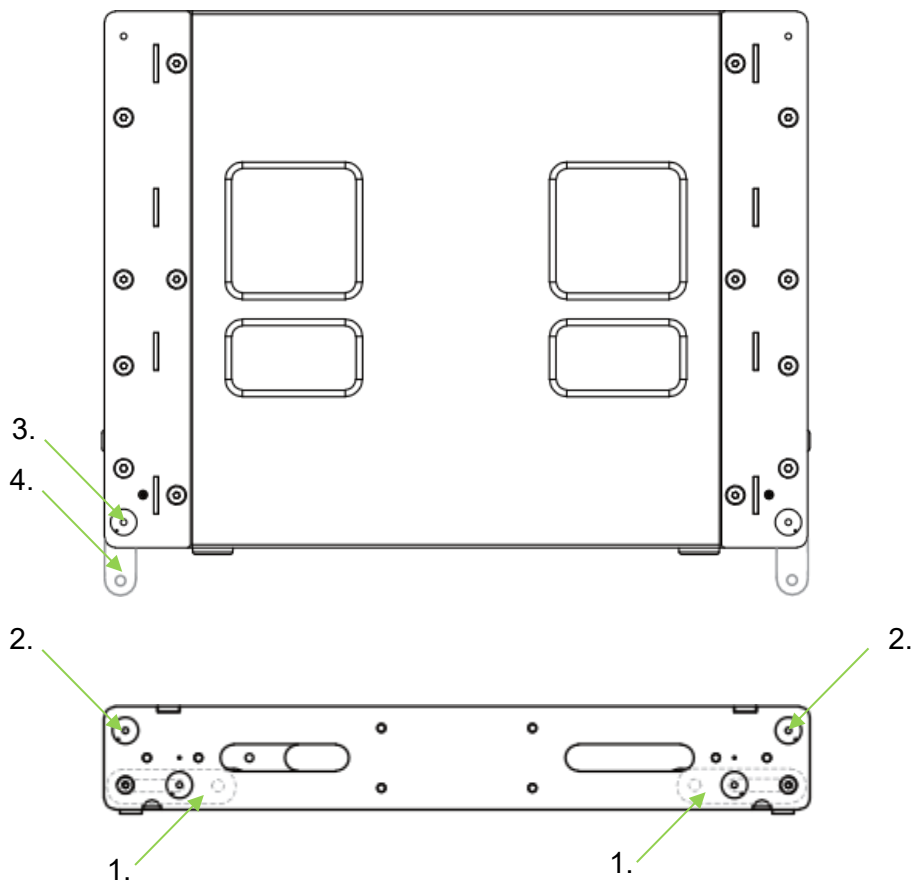

### 8.5.3 Fixing the top section under the L-118 SA flying frame of the transport dolly

- Remove the two internal front plug-in bolts (1.) in the flying frame. The connecting slides (2.) for connecting a top section fold downwards.
- Now lift the array with these connecting slides (2.) into the corresponding grooves (left and right of the front grille) of the top section of the next transport dolly.
- Fix the connecting slides through the upper holes (3.) on the front of the top section with the internal plug-in bolts (1.) of the flying frame.
- Remove the rear internal LINK pin (4.) of the flying frame
- Now push the load bar (5.) of the top section upwards, until it touches the LOCK pin (6.) of the flying frame.
- Now secure the load bracket (5.) with the LINK pin (4.).
- Remove the LOCK pins (7.) from all top sections on the transport dolly. The LINK pins (10.) always remain inserted.
- To set the desired angle, remove the angle pin (8.) from the top section underneath and slide the load bracket (9.) upwards until the groove in the load bracket matches the desired angle on the scale on the right-hand side of the mounting rail
- Then insert the angle pin (8.) from the left-hand side of the mounting rail through the hole with the desired angle
- Repeat this step accordingly with the next top sections.

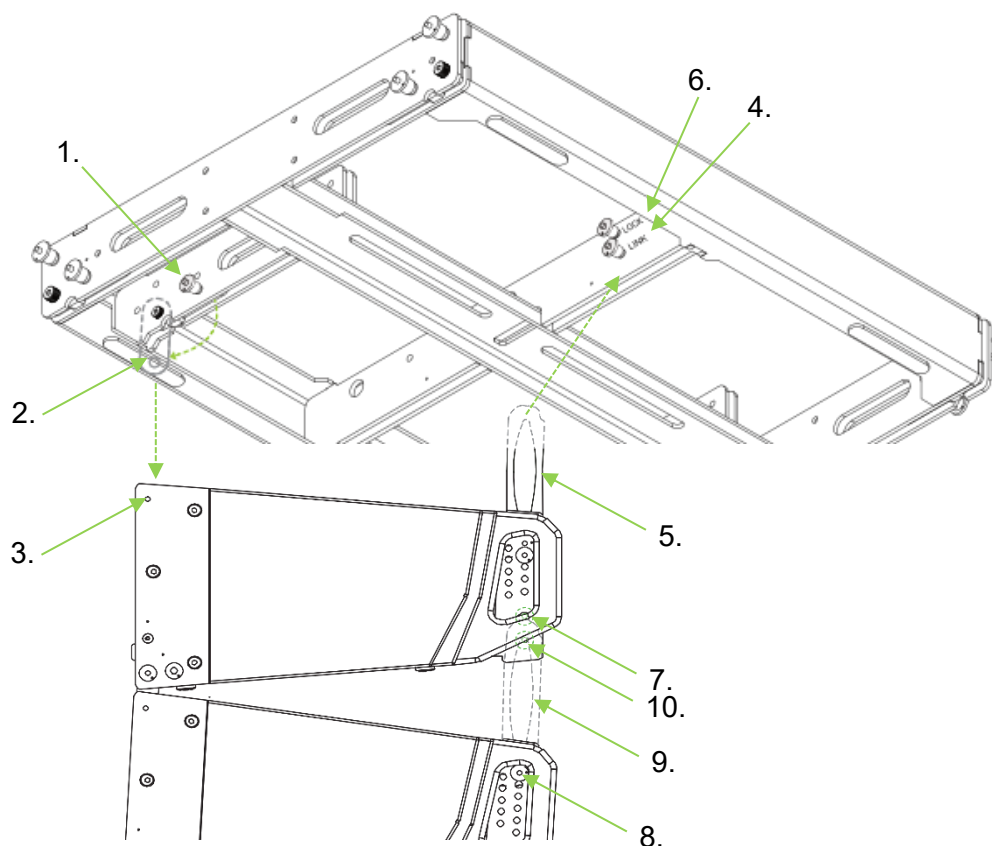

**NOTE**

To connect the uppermost top section to the flying frame, ALWAYS set 2° to achieve a 0° angle.

Follow the instructions on the flying frame!

- Now remove the three plug-in bolts (11.) that secure the top sections on the transport dolly.
- You can now lift the tops out of the dolly. This will automatically create the set angles.
- As soon as the array is under load, put all the lock pins back into position to lock the brackets in place.

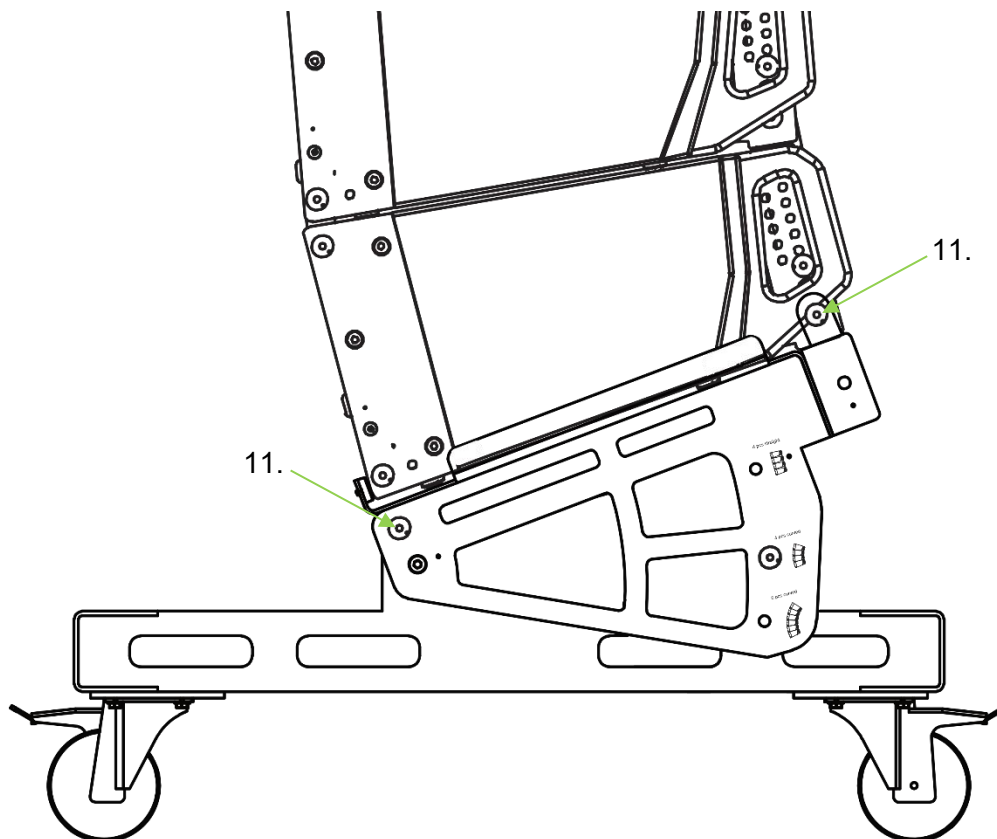

#### 8.5.4 Fixing the top section to the top section of the transport dolly

- Remove the front plug-in bolts (1.) from the bottom top section of the array. The connecting slide (2.) will slide downwards out of the housing. Secure the slide directly with the plug-in bolts (1.) in the same plug-in position.
- Now lift the array with these connecting slides flush to the front into the corresponding grooves of the top section of the next transport dolly.
- Then make the connection with the hole in the connecting slide by inserting the rear pins (3.) of the lowest suspended top section into the holes (4.) on the top of the top section below, where the ends of the connecting slides (2.) are also inserted.
- Remove the LINK pin (5.) from the lowest suspended top section.
- Now push the load bar (6.) of the topmost top section on the transport dolly upwards, until it touches the LOCK pin (7.) of the lowest hanging top section.
- The load bracket (6.) can be fixed in this position with the LINK pin (5.).
- Now remove the LOCK pins (8.) from all tops on the transport dolly. The LINK pins always remain inserted.
- To set the desired angle, remove the angle pin (9.) from the top section underneath and slide the load bracket (10.) upwards, until the groove in the load bracket matches the desired angle on the scale on the right-hand side of the mounting rail (for details, see chapter 3.1.1)
- Then insert the angle pin (11.) from the left-hand side of the mounting rail through the hole with the desired angle
- Repeat this step accordingly with the next top sections.
- Now remove the three pins (12.) that secure the top sections on the transport dolly.
- You can now lift the tops out of the dolly. This will automatically create the set angles.
- As soon as the array is under load, put all LOCK pins (8.) back into position to lock the brackets.

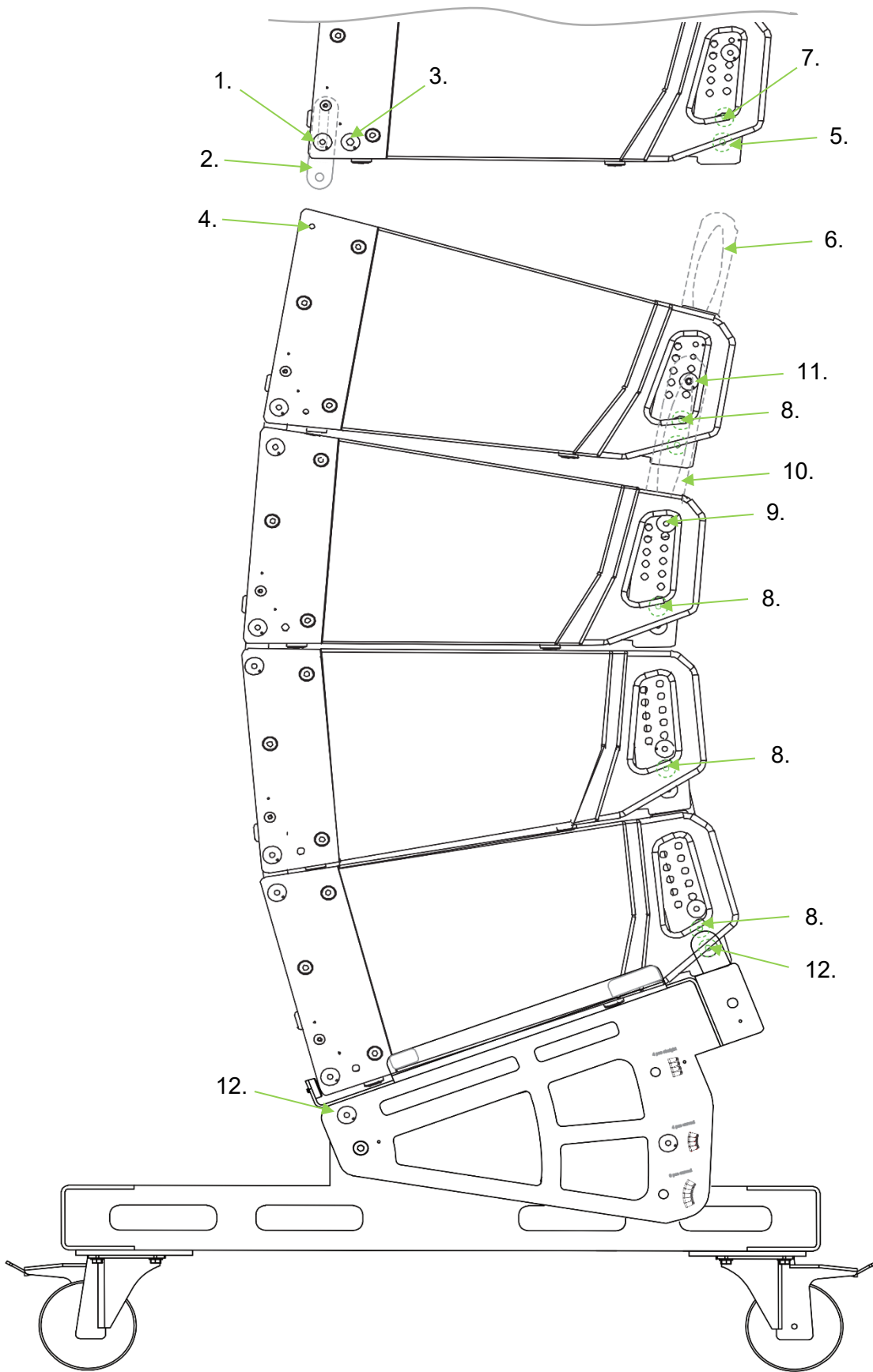

## 9 Specifications

### 9.1 XANA L-208 TA Line Array Top 1,400W

<b>Structure</b>	3-way active
<b>Frequency response</b>	65Hz - 20KHz (-10dB)
<b>Max SPL</b>	132 dB
<b>Loudspeaker</b>	2x 1.35" / 8Ω / CD horn 2x 8" neodymium / 4Ω / 2 "v.c
<b>Beam angle</b>	90° horizontal 12° vertical
<b>Amplifier power</b>	1,400 W RMS 2,800 W peak
<b>Cooling</b>	No fan, convection cooling
<b>Mains voltage</b>	220-240V / 50-Hz
<b>Controller</b>	DSP 32 bit
<b>Network</b>	RS 485 Protocol
<b>LED display</b>	Input signal, limit
<b>Signal connections</b>	Line Input 1x XLR 3-pin female, balanced Line Out 1x XLR 3-pin female, balanced
<b>Network connections</b>	DATA Input Network b. (etherCON compatible) DATA Link Netzwerk b. (etherCON compatible)
<b>Power connections</b>	Mains Input 1x PowerCON TRUE1 Mains Link 1x PowerCON TRUE1
<b>Power consumption</b>	3.7A max. (850W)
<b>Work area</b>	-5°C to 40°C   max. 5,000m above sea level
<b>Housing</b>	Birch plywood with polyurethane coating
<b>Flight system</b>	3 point
<b>Width x height x depth</b>	620 x 250 x 470 mm
<b>Weight</b>	27.5 kg

## 9.2 XANA L-118 SA line array subwoofer 2,800W

<b>Structure</b>	Active line array subwoofer, airborne
<b>Frequency response</b>	34Hz - 150Hz (-10dB)
<b>Max SPL</b>	138 dB
<b>Loudspeaker</b>	1x 18" neodymium / 4Ω / 4" v.c
<b>Amplifier power</b>	2,400 W RMS 4,800 W peak
<b>Cooling</b>	No fan, convection cooling
<b>Mains voltage</b>	220 - 240V / 50Hz
<b>Controller</b>	DSP 32 bit
<b>Network</b>	RS 485 protocol
<b>LED display</b>	Input signal, limit
<b>Signal connections</b>	Line Input 1x XLR 3-pin female, balanced Line Out 1x XLR 3-pin female, balanced
<b>Network connections</b>	DATA Input Network b. (etherCON compatible) DATA Link Netzwerk b. (etherCON compatible)
<b>Power connections</b>	Mains Input 1x PowerCON TRUE1 Mains Link 1x PowerCON TRUE1
<b>Power consumption</b>	10.3A max. (2,360W)
<b>Work area</b>	-5°C to 40°C   max. 5,000m above sea level
<b>Housing</b>	Birch plywood with polyurethane coating
<b>Flight system</b>	4 point
<b>Width x height x depth</b>	840 x 495 x 655 mm
<b>Weight</b>	71.4 kg

### 9.3 XANA L-208 TA flying frame

<b>Structure</b>	Steel construction
<b>Diameter pick point</b>	20mm
<b>Width x height x depth (without pins)</b>	622 x 84 x 520 mm
<b>Weight</b>	15.65 kg

### 9.4 XANA L-118 SA flying frame

<b>Structure</b>	Steel construction
<b>Diameter pick point</b>	20mm
<b>Width x height x depth (without pins)</b>	840 x 85 x 650 mm
<b>Weight</b>	31.81 kg

## 10 Maintenance



**DANGER**

Suspension systems consist of mechanical components and must therefore be regularly inspected and maintained to ensure their proper function and safety.

Before installing a loudspeaker system, it is essential to ensure that all components - such as the housing, flying frame, bolts, locking pins, split pins, etc. - are checked for cracks, deformation, corrosion and missing, loose or damaged parts. Such defects can significantly impair the load-bearing capacity and safety of the entire system.

A loudspeaker must not be suspended or placed on a stand until all necessary measures have been taken to rectify any defects found.

Installed systems must be inspected at least once a year. This inspection should include a visual inspection of all load-bearing components - in particular for cracks, deformation, moisture damage or other signs that could jeopardise the structural integrity of the speaker enclosure. Defective components must not be put into operation.



## 11 Cleaning

Use a lint-free and only slightly damp cloth for cleaning. Chemical cleaners may contain solvents, which can damage the surfaces.

### WEEE declaration (Waste of Electrical and Electronic Equipment)

Your product has been developed and manufactured using high-quality materials and components that are recyclable and reusable. The symbol means that your product must be disposed of separately from household waste at the end of its service life.

Dispose of this appliance at your local collection point or recycling centre.

Please help to protect the environment in which we all live.

All technical data and appearances are subject to change without prior notice. All information was correct at the time of printing. Musikhaus Kirstein GmbH accepts no liability for the accuracy or completeness of the descriptions, photos or statements contained in this manual. Printed colours and specifications may differ slightly from the product. Musikhaus Kirstein GmbH products are only sold through authorised dealers. Distributors and dealers are not representatives of Musikhaus Kirstein GmbH and are not authorised to legally bind Musikhaus Kirstein GmbH in any way.

**Musikhaus Kirstein GmbH**  
**Bernbeurener Street 11**  
**86956 Schongau - Germany**  
**Phone: 0049-8861/909494-0**  
**info@kirstein.de**



## XANA Line Array System



Operating instructions

## Contents

<b>1 Safety instructions and warning symbols .....</b>	<b>1</b>
1.1 General information.....	1
1.2 Intended use .....	1
1.3 Explanation of symbols and terms.....	2
1.4 Safety instructions .....	3
<b>2 Packaging.....</b>	<b>6</b>
2.1 Note .....	6
2.2 Scope of delivery.....	6
<b>3 System components.....</b>	<b>7</b>
3.1 XANA L-208 TA Line Array Top 1,400W .....	7
3.1.1 Mechanics .....	7
3.1.2 Electronics .....	9
3.2 XANA L-118 SA line array subwoofer 2,400W.....	10
3.2.1 Mechanics .....	10
3.2.2 Electronics .....	12
3.3 Accessories.....	13
3.3.1 XANA L-208 TA flying frame incl. flybar .....	13
3.3.2 XANA L-118 SA flying frame incl. flybar .....	14
3.3.3 XANA L-208 TA Transport Dolly .....	15
3.3.4 Other accessories.....	16
<b>4 DSP settings .....</b>	<b>19</b>
4.1 XANA L-208 TA.....	19
4.1.1 Start screen .....	19
4.1.2 Main menu.....	19
4.1.3 Submenu .....	20
4.2 XANA L-118 SA .....	22
4.2.1 Start screen .....	22
4.2.2 Main menu.....	22

4.2.3 Submenu .....	22
<b>5 P.sysMANAGER - Software.....</b>	<b>25</b>
<b>6 EASE Focus 3 - Software .....</b>	<b>26</b>
<b>7 Load limits.....</b>	<b>27</b>
7.1 XANA L-208 TA flying frame incl. flybar.....	28
7.2 XANA L-118 SA flying frame incl. flybar .....	29
<b>8 Assembly.....</b>	<b>30</b>
8.1 Connections .....	31
8.1.1 Locking pin with locking mechanism .....	31
8.1.2 Connecting bolt with safety split pin .....	32
8.2 Transport dolly .....	33
8.2.1 Adjusting the base plate.....	33
8.2.2 Fixing the top section to the base plate.....	34
8.2.3 Fixing top section to top section .....	35
8.3 Ground stack.....	36
8.3.1 Fixing subwoofer to subwoofer.....	36
8.3.2 Flying frame on subwoofer.....	37
8.3.2.1 Using the Xana L-118 SA flying frame.....	37
8.3.2.2 Using the Xana L-208 SA flying frame with stand base .....	38
8.3.3 Fixing the top section to the flying frame .....	39
8.3.4 Fixing the top section to the top section .....	40
8.4 Flown system without subwoofer.....	41
8.4.1 Fixing the flying frame to top sections with transport dolly.....	41
8.4.2 Fixing flying top section on top section with transport dolly .....	43
8.5 Flown system with subwoofer.....	45
8.5.1 Fixing the L-118 SA flying frame to the subwoofer .....	45
8.5.2 Fixing the L-118 SA flying frame under the subwoofer .....	46
8.5.3 Fixing the top section under the L-118 SA flying frame of the transport dolly .....	47
8.5.4 Fixing the top section to the top section of the transport dolly .....	49

<b>9 Specifications</b> .....	<b>51</b>
9.1 XANA L-208 TA Line Array Top 1,400W .....	51
9.2 XANA L-118 SA line array subwoofer 2,800W.....	52
9.3 XANA L-208 TA flying frame .....	53
9.4 XANA L-118 SA flying frame .....	53
<b>10 Maintenance</b> .....	<b>53</b>
<b>11 Cleaning</b> .....	<b>55</b>

© 2025

These operating instructions are protected by copyright. Reproduction of these operating instructions, even in part, is only permitted with the authorisation of Musikhaus KIRSTEIN GmbH. The same applies to the reproduction or copying of images, even in modified form.

Thank you for choosing a product from PRONOMIC. You have made a good choice. PRONOMIC has been synonymous with high-quality audio products at a fair price-performance ratio for many years. You can find more information about the XANA series at <https://www.kirstein.de/Xana> . We wish you many interesting and successful projects using the XANA line array series.

## **1 Safety instructions and warning symbols**

### **1.1 General information**

Please read these operating instructions carefully and completely before using the XANA line array system. Only then, a safe and trouble-free operation is guaranteed.

If any formulations, specifications or procedures in these instructions are unclear to you, do not use the system under any circumstances.

Observe the warnings on the device and in the operating instructions.

Keep these operating instructions in a safe place within easy reach. The operating instructions are an integral part of the product and must be passed on to all subsequent users.

### **1.2 Intended use**

The devices of the Pronomic XANA series have been developed for professional audio applications. Therefore, they are only intended for use by qualified personnel with specialist knowledge. These devices are not suitable for domestic use. Any use outside the described technical data and application conditions is considered improper use!

The products of the XANA Line Array series are not suitable for children and persons with insufficient experience and training. No liability is accepted for damage, including damage to third parties and their property, caused by improper use.

All information in these operating instructions have been checked to the best of our knowledge and belief. However, neither the author nor the publisher can be held liable for any damages related to the use of these operating instructions.

Other product, brand and company names mentioned in this document may be the trademarks of their respective owners. Compliance with all applicable copyright laws is the responsibility of the user of this document.

### 1.3 Explanation of symbols and terms



The manual refers the user to additional information on the product.



The exclamation mark draws the user's attention to important information in the operating instructions that must be observed.



The hearing protection warns the user of the dangers of high volumes.



The flash warns the user of the dangers of electric current and magnetic fields.

#### **DANGER**

Indicates an immediately life-threatening situation. Failure to comply poses an acute danger to life and limb. Can be supplemented by a symbol.

#### **WARNING**

Indicates a potentially hazardous situation which, if not avoided, could result in serious injury or death. Can be supported by a symbol.

#### **NOTE**

The signal word NOTICE indicates general precautionary measures that should be observed when handling the product. Can be supplemented by a symbol.

## 1.4 Safety instructions

These operating instructions apply to persons who have been supervised or instructed in the operation of the appliance by a person responsible for their safety and who have demonstrated that they are able to handle the appliance.



**Children should be supervised to ensure that they do not play with the appliance.  
Do not leave children unattended.**



**DANGER**

Never disassemble your appliance. An incorrectly repaired appliance can be dangerous for the user. If you have any problems, please contact our service centre.

Comply with the trade association regulation "BGV A2 - Electrical systems and equipment".

Do not use the appliance near water (e.g. near a bathtub, washbasin, sink, in a damp cellar or near a swimming pool, etc.).

Check the mains cable for damage before each use. If you notice any damage, the mains cable must be replaced.

The speaker system must not be set up near heat sources such as radiators, fan heaters or other devices that generate heat. The speakers must be protected from direct sunlight, as this can cause the electronics to fail due to overheating.

The appliance may only be connected to a power supply that corresponds to the type described in the operating instructions or indicated on the appliance.

The product should be serviced by qualified service personnel if:

- objects have fallen into the appliance or liquid has been spilled on the appliance
- The device was exposed to rain
- The device does not appear to be functioning normally or there is a significant change in performance
- The device has been dropped or the housing has been damaged
- Do not attempt to service the appliance beyond the measures described in the maintenance instructions. All other maintenance work should be carried out by qualified service personnel.

**WARNING**

This loudspeaker system can generate sound levels that can lead to permanent hearing loss. During operation, ensure that you comply with the legal requirements for accident prevention and the "BGV B3 - Noise" of the employers' liability insurance association.

Do not operate the device at a high volume or at a level that is uncomfortable for a long period of time. If you notice hearing loss or ringing in your ears, you should consult an ear specialist.

Wear hearing protection during operation and do not stand in the immediate vicinity of the speakers.

Never climb on the hanging or standing system.

**NOTE**

Read all instructions before using the product.

Images and screen displays in these operating instructions may differ slightly from the appearance of the actual product as long as this has no negative impact on the technical properties and safety of the product.

All personal formulations in these operating instructions are to be regarded as gender-neutral.

The warranty is void if the product is damaged due to improper use.

Make sure that no objects fall into the openings of the housing and that no liquids penetrate.

Do not cover any ventilation openings.

Protect the speaker system from rain or moisture. The operating temperature range is between +40°C and -5°C.

**DANGER**

Only use the accessories specified by the manufacturer.

Ensure that suitable protective clothing is worn during assembly and dismantling and observe all relevant accident prevention regulations.

During assembly and dismantling, mechanically moving devices and falling parts can pose a considerable risk of injury. Therefore, please observe the relevant trade association regulations:

- DGUV Regulation 54 - "Winches, lifting and pulling equipment"
- DGUV Regulation 1 - "Principles of prevention"
- DGUV Regulation 17 - "Event and production venues for scenic presentation"

DGUV Information 215-313 "Loads above persons" must also be observed.

The mounting accessories supplied with the XANA line array system or specially designed for this purpose must also be checked for wear and functionality at least once a year - or in accordance with applicable local regulations. Particular attention must be paid to signs of corrosion, bending, material fatigue or other impairment of stability.

The respective inspection and maintenance specifications of the manufacturer apply to other slings.

Before any installation, a competent person with experience and training in handling speaker suspension systems should carefully check all components and connections.

The structure is designed for operation in enclosed spaces (exhibition halls, event halls, etc.). Outdoor operation is permitted, provided that the wind loads at the top and bottom ends are transferred horizontally and the structure is lowered at wind speeds above 8 Bft.

All slings must be dimensioned, planned and their installation monitored by specialised personnel in accordance with the explanations in DGUV Information 215-313 (BGI 810-3) on DGUV Regulation 17 (UVV BGV-C1).

All connections must be secured against loosening.

Please refer to the information in IGWV Guideline SQ P1 regarding protective equipotential bonding, lightning protection and defect testing of the components used.

## 2 Packaging

### 2.1 Note



Open the shipping carton carefully and check for visible damage. Each PRONOMIC XANA Series device is fully tested and inspected before leaving the factory and should arrive in perfect condition. If you notice any damage, notify the shipping company immediately. Save the carton and all packing materials for inspection by the carrier.

### 2.2 Scope of delivery

#### XANA L-208 TA Line Array Top

- 1x L-208 TA Line Array top unit
- 1x operating instructions
- 1x mains cable

#### XANA L-118 TA Line Array Subwoofer

- 1x L-118 SA line array subwoofer
- 1x operating instructions
- 1x mains cable

#### XANA flying frame L-208 TA and L-118 SA

- 1x flying frame
- 1x flybar
- 1x operating instructions

#### XANA L-208 TA and L-118SA Transport Dolly

- 1x transport dolly
- 4x swivel castor
- 1x operating instructions

## 3 System components

### 3.1 XANA L-208 TA Line Array Top 1,400W

#### 3.1.1 Mechanics

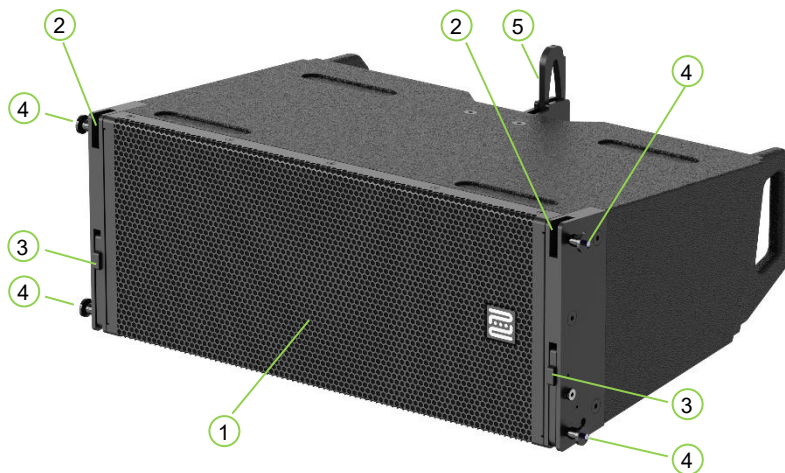

**No. Description of the**

- 1 XANA L-208 TA top
- 2 Connection opening for attaching the speaker to the front connecting slide of the flying frame or the top section above it
- 3 Front connecting slide for attaching an additional L-208 TA top unit
- 4 Socket pin with locking mechanism
- 5 Load bracket for connecting the speaker to the flying frame or for connecting to the top above it

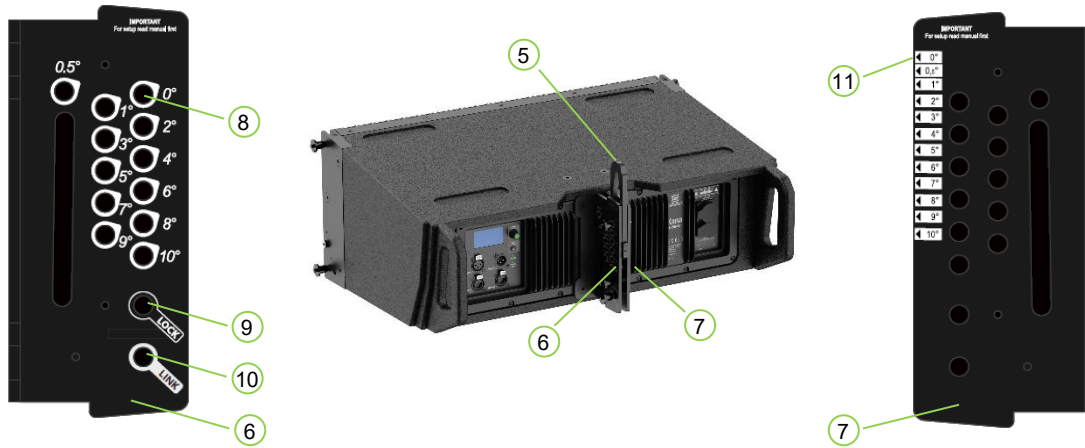

**No. Description of the**

- 5 Load bracket for connecting the speaker to the flying frame or for connecting to the top above it
- 6 Mounting rail (left side) incl. load bracket
- 7 Mounting rail (right-hand side) incl. load bracket
- 8 12 plug-in positions for the connecting pin to set the desired angle between 0.5° and 10°. This is used to fix the load bracket (5).
- 9 Plug-in position (LOCK) for fixing the position of the load bar of an L-208 TA top unit
- 10 Plug-in position (LINK) for mounting the load bracket of an L-208 TA top underneath
- 11 Imprint for checking the angle setting of 0.5°-10°. The angle is set with the arrow pointing to the marking (groove) in the load bracket (see Fig. 2)
- 12 Marking (groove) in the load bar

**Example:**

Image 1: Socket pin was set at 10°

Image 2: Groove in the load bracket points to 10° marking

Picture 1

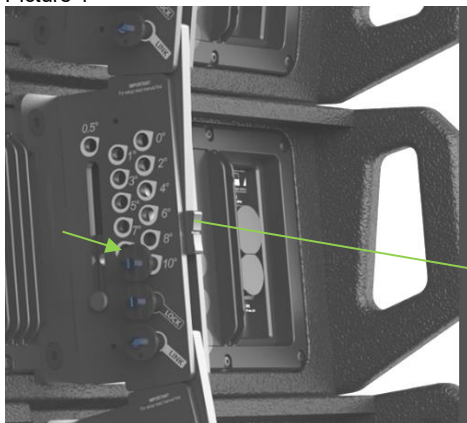

Picture 2



## 3.1.2 Electronics

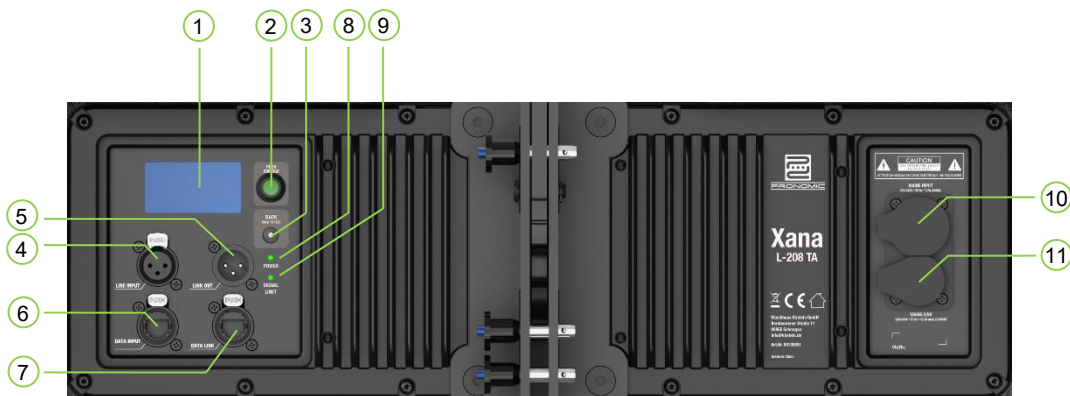

### No. Description of the

- 1 **LCD screen:** Provides access to speaker operating modes, DSP parameters, network settings and more
- 2 **PUSH FOR DSP:** Rotary control for parameter setting with push function to confirm the choice.
- 3 **BACK & HOLD TO TEST:** Button is used in conjunction with the rotary control to control the parameters displayed on the LCD screen.  
Short press = "back"  
Long press = (>5 sec.) starts a frequency sweep signal for speaker test
- 4 **LINE INPUT:** XLR input (balanced)  
The input signal is fed directly to the DSP.
- 5 **LINE OUT:** XLR output (balanced)  
The output receives the direct signal from the input and bypasses the DSP so that there is no latency. The output continues to function even in the event of a power failure.
- 6 **DATA INPUT:** etherCON network socket for controlling the parameters via RS485 protocol.
- 7 **DATA LINK:** etherCON network socket for connecting an additional device.
- 8 **POWER:** LED indicates whether the device is supplied with power.
- 9 **SIGNAL / LIMIT:** LED indicates whether signal is present or the amplifier is being overdriven
- 10 **MAINS INPUT:** Power connection input (powerCon True1 compatible)
- 11 **MAINS LINK:** Power connection output (powerCon True1 compatible) is used to supply power to other devices. ATTENTION: Do not exceed the max. power specifications.

**3.2 XANA L-118 SA line array subwoofer 2,400W**

3.2.1 Mechanics

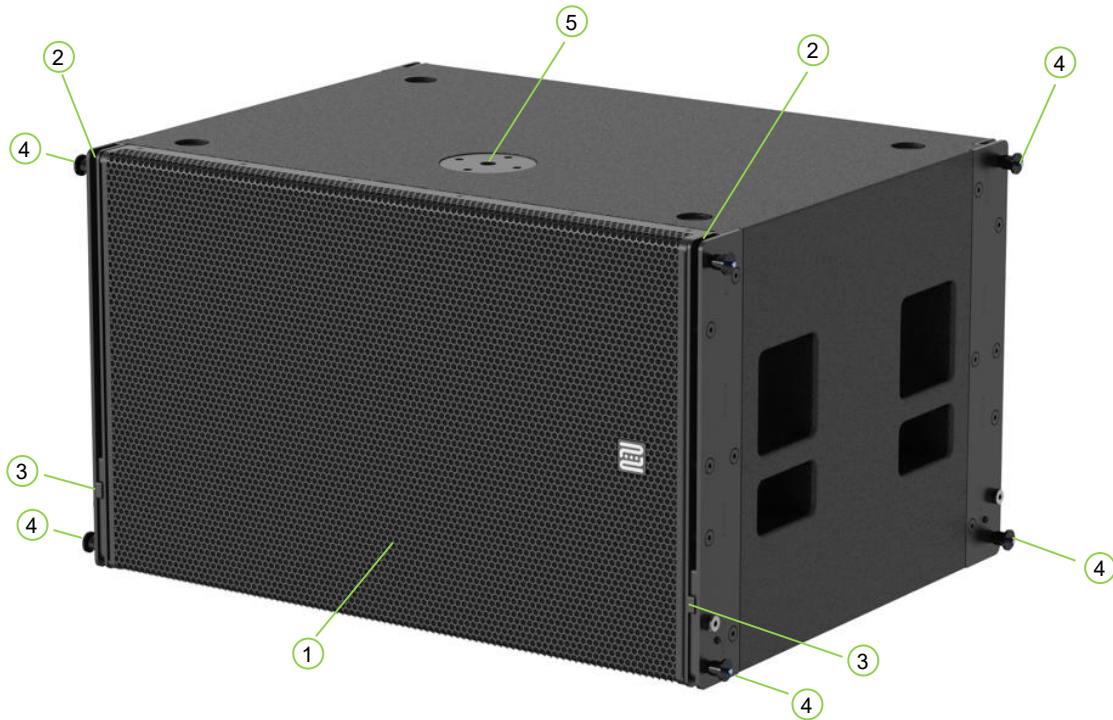

**No. Description of the**

- 1 XANA L-118 SA subwoofer
- 2 Connection opening for attaching the speaker to the connecting slide of the flying frame or the subwoofer above it
- 3 Connecting slide for mounting an L-118 SA subwoofer underneath
- 4 Socket pin with locking mechanism
- 5 M20 threaded sleeve

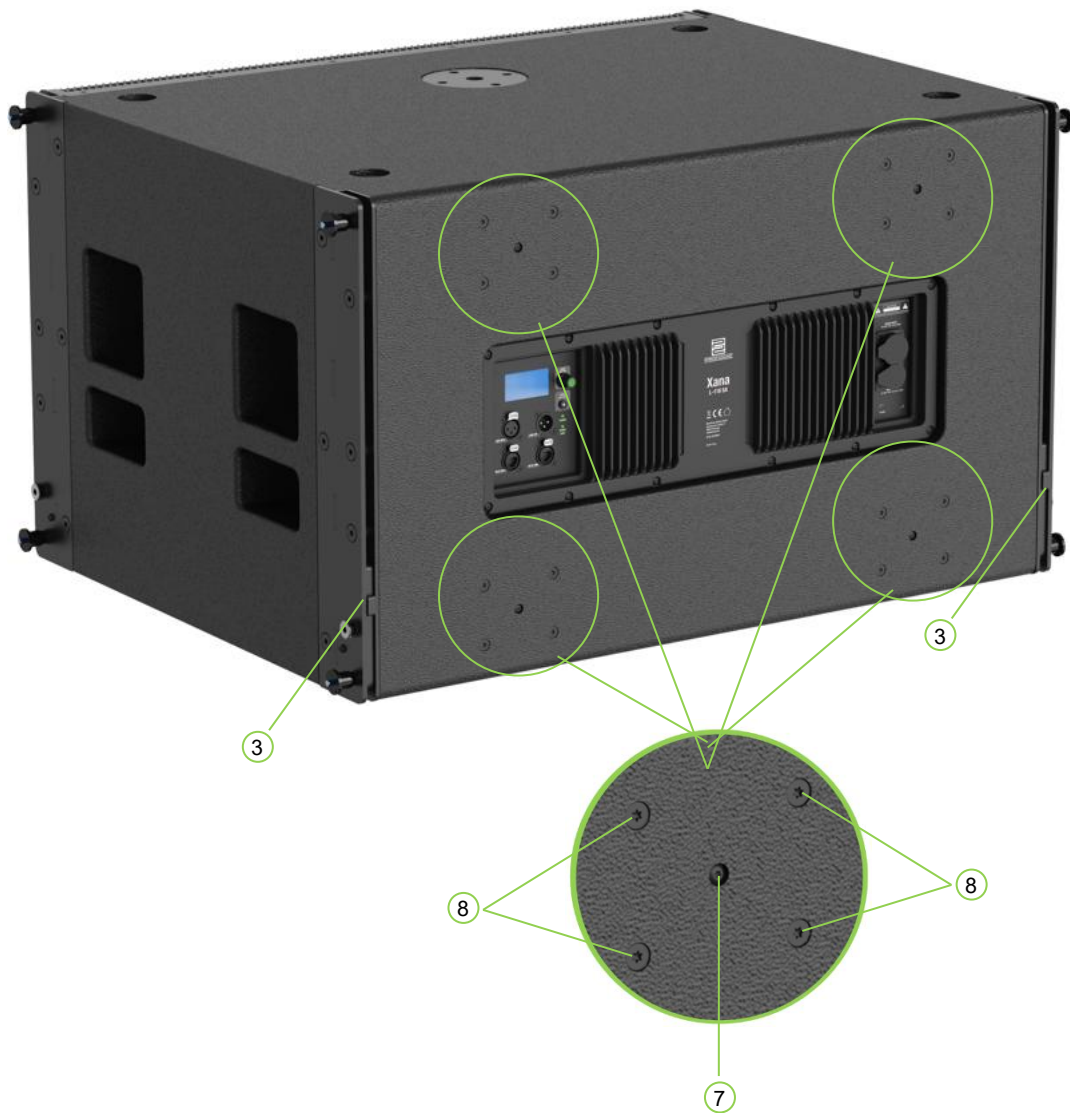

**No. Description of the**

- 7 Drive-in nut for fastening the rubber feet
- 8 M8 drive-in nuts for fastening transport rollers (hole size 80 mm x 60 mm)

## 3.2.2 Electronics

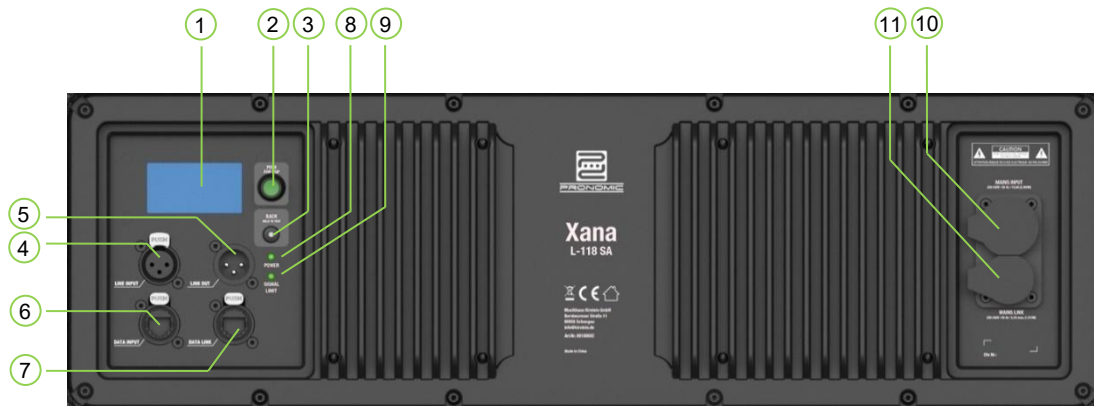

### No. Description of the

- 1 **LCD screen:** Provides access to speaker operating modes, DSP parameters, network settings and more
- 2 **PUSH FOR DSP:** Rotary control for parameter setting with push function to confirm the choice.
- 3 **BACK & HOLD TO TEST:** Button is used in conjunction with the rotary control to control the parameters displayed on the LCD screen.  
Short press = "back"  
Long press = (>5 sec.) starts a frequency sweep signal for speaker test
- 4 **LINE INPUT:** XLR input (balanced)  
The input signal is fed directly to the DSP.
- 5 **LINE OUT:** XLR output (balanced)  
The output receives the direct signal from the input and bypasses the DSP so that there is no latency. The output continues to function even in the event of a power failure.
- 6 **DATA INPUT:** etherCON network socket for controlling the parameters via RS485 protocol.
- 7 **DATA LINK:** etherCON network socket for connecting an additional device.
- 8 **POWER:** LED indicates whether the device is supplied with power.
- 9 **SIGNAL / LIMIT:** LED indicates whether a signal is present or whether the amplifier is being overdriven.
- 10 **MAINS INPUT:** Power connection input (powerCon True1 compatible)
- 11 **MAINS LINK:** Power connection output (powerCon True1 compatible) is used to supply power to other devices. ATTENTION: Do not exceed the max. power specifications.

## 3.3 Accessories

### 3.3.1 XANA L-208 TA Flying frame incl. flybar

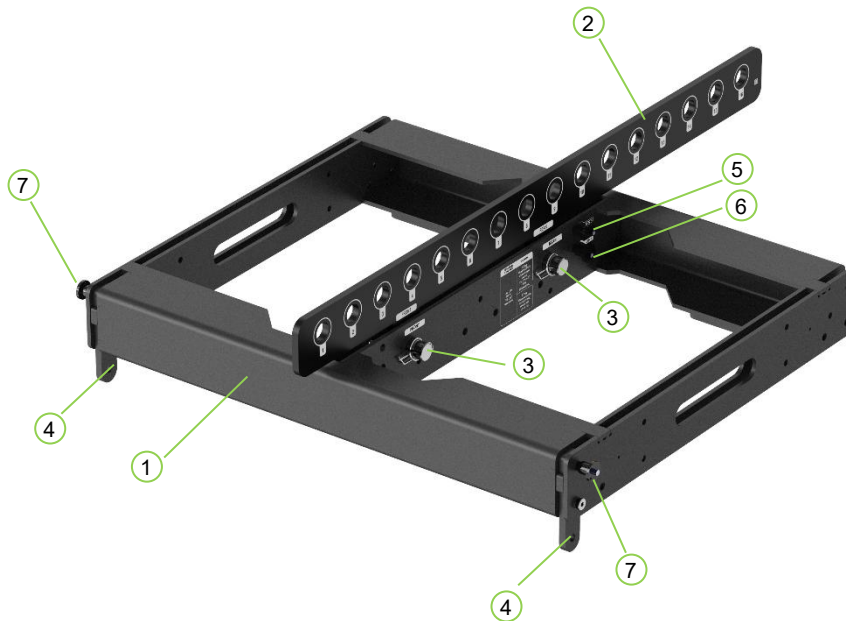

#### No. Description of the

- 1 The flying frame is designed to accommodate up to 16 flown XANA L-208 TAs
- 2 The flybar provides 16 possible hanging points (pick points). The diameter is 20 mm.
- 3 Connecting bolt between flying frame and flybar with safety pin
- 4 Front connecting slide for mounting an L-208 TA top unit
- 5 Rear connection point (LINK) for mounting the load bar of an L-208 TA top section
- 6 Rear connection point (LOCK) for fixing the position of the load bar of an L-208 TA top section
- 7 Socket pin with locking mechanism

The flybar can be used in both '**normal**' and '**inverse**' modes.

The '**normal**' mode is shown in the illustration. In this case, the '**FRONT**' marking on the flybar must be aligned with the '**FRONT**' marking on the airframe.

For "inverted" use, the flybar must be rotated by 180°. In this case, the "**FRONT**" marking on the flybar must be aligned with the "**REAR**" marking on the flying frame.

## 3.3.2 XANA L-118 SA flying frame incl. flybar

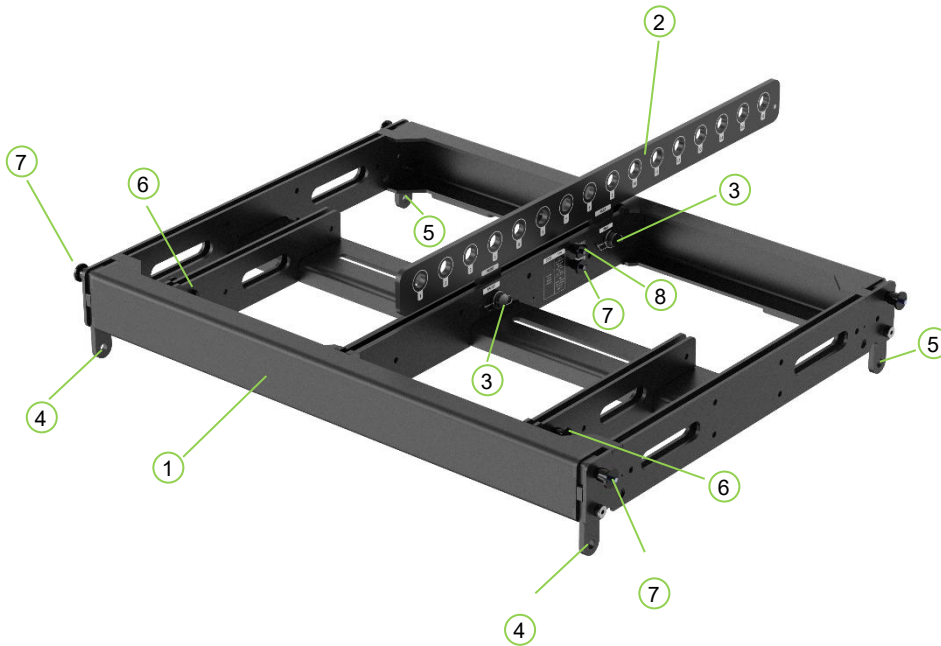

### No. Description of the

- 1 The flying frame is designed to accommodate up to 8 flown XANA L-118 subwoofers or 16 flown XANA L-208 subwoofers. Permitted combinations are also possible.
- 2 The flybar provides 16 possible hanging points (pick points). The diameter is 20 mm.
- 3 Connecting bolt between flying frame and flybar with safety pin
- 4 Front connecting slide for mounting an L-118 SA subwoofer
- 5 Rear connecting slide for mounting an L-118 SA subwoofer
- 6 Front connection point for mounting an L-208 TA top unit
- 7 Rear connection point (LINK) for mounting the load bar of an L-208 TA top section
- 8 Rear connection point (LOCK) for fixing the position of the load bar of an L-208 TA top section

The flybar can be used in both 'normal' and 'inverse' modes.

The 'normal' mode is shown in the illustration. In this case, the 'FRONT' marking on the flybar must be aligned with the 'FRONT' marking on the airframe.

For "inverted" use, the flybar must be rotated by 180°. In this case, the "FRONT" marking on the flybar must be aligned with the "REAR" marking on the flying frame.

## 3.3.3 XANA L-208 TA Transport Dolly

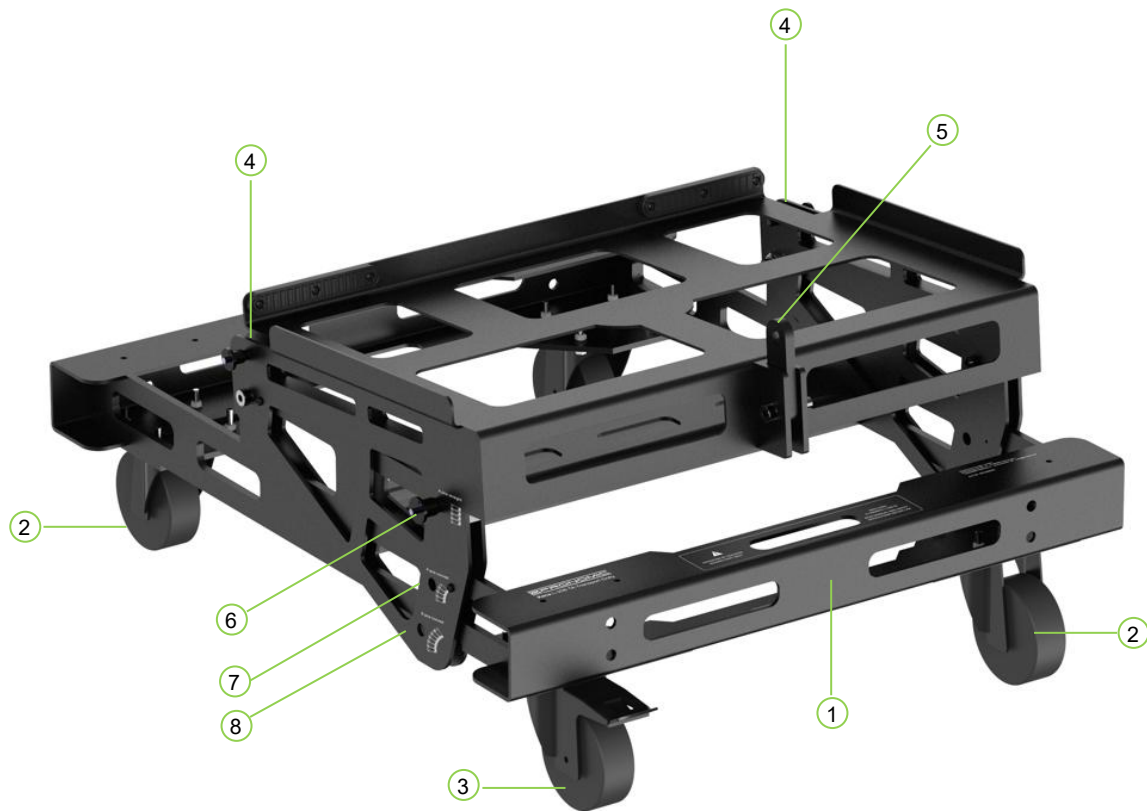

**No. Description of the**

- 1 The transport dolly is designed for convenient transport of up to 6 L-208 TA speakers
- 2 2 unbraked transport castors
- 3 2 braked transport castors
- 4 Connection opening for attaching the front connecting slide of the surface-mounted top section L-208 TA
- 5 Rear connection point for fixing the L-208 TA top in place via the LINK pin (similar to the load bracket of an L-208 TA top, only shortened)
- 6 "Straight" angle adjustment for upright mounting of up to 4 L-208 TA tops
- 7 Angle adjustment "4pcs curved" for angled mounting of up to 4 tops L-208TA
- 8 Angle adjustment "6pcs curved" for angled mounting of up to 6 tops L-208TA

### 3.3.4 XANA L-118 SA Transport Dolly

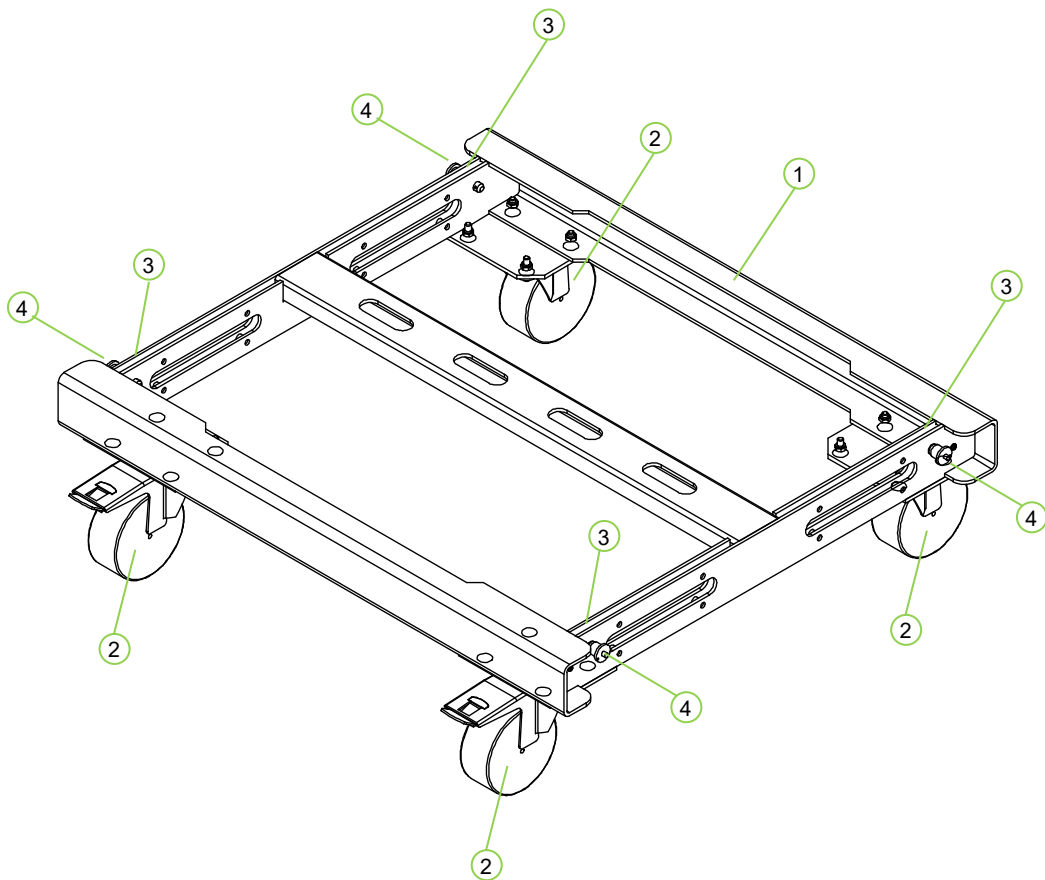
**Nr. Beschreibung**

- 1 The transport dolly is designed for convenient transport of up to 3 L-118 SA speakers
- 2 4 braked transport castors (125mm / 400kg load capacity)
- 3 Connection opening for attaching the speaker to the connecting slide of the flying frame or the subwoofer above it
- 4 Socket pin with locking mechanism

### 3.3.5 Other accessories

#### XANA Standbase für L-208TA Flugrahmen

For mounting the XANA L-208TA flying frame on the L-118SA subwoofer for use as a ground stack

Item no. 0011195

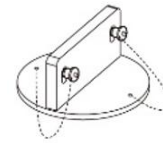

#### XANA Tilt Unit für L-208TA und L-118SA Flugrahmen

For connecting the XANA L-208TA speaker to the L-208TA and L-118SA flying frame. Angle settings from 0° to 10° possible.

Item no. 0011194

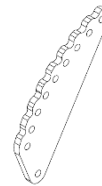

#### XANA L-208TA Schutzhülle für 4 Stück

Protective or transport cover for 4x XANA L-208TA speakers angled at 10° on the transport dolly.

Item no. 00108694



#### XANA L-208TA Schutzhülle für 6 Stück

Protective or transport cover for 6x XANA L-208TA speakers angled at 10° on the transport dolly.

Item no. 00108695



#### XANA L-118SA Schutzhülle

Protective and transport cover for XANA L-118SA subwoofer

Item no. 00108699

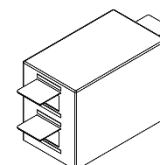

**XANA L-118SA Schutzhülle für 3 Stück**

Protective and transport cover for  
3x XANA L-118SA subwoofer on the dolly

Item no. 00108990

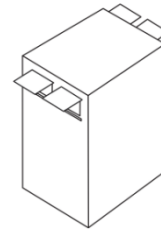

**XANA L-208 TA Regenschutz für Elektronik**

Metal frame with foldable fabric to protect  
the electronics

Item no. 00111201



**XANA L-118 SA Regenschutz für Elektronik**

Metal frame with foldable fabric to protect  
the electronics

Item no. 00111203



**Lenkrollen Satz 2x m.Bremse, 2x o.Bremse**

Castor set suitable for XANA L-118SA subwoofer  
hole size 80mm x 60mm / castor diameter 100mm

Item no. 00111805



**Pronomic USB-RS485 Interface für P.sysManager**

USB interface with etherCon compatible network socket  
for controlling the XANA L-208TA and L-118SA speakers

Item no. 00108696



## 4 DSP settings

The LCD screen on the back provides a user-friendly interface for setting various devices, speaker and network parameters.

Navigation through the menus is via the **"PUSH FOR DSP" endless controller**:

- **Turn** the control to scroll through menus and options.
- **Press** the slider to start editing a selected parameter.
- **Turn** again to set the desired value and
- **Press** again to confirm the selected value.

Press the **"BACK" button** to return to the previous menu. If you are in a confirmation dialogue, you can cancel the process with the BACK button.

All settings on the appliance are retained even after a power failure.

### 4.1 XANA L-208 TA

#### 4.1.1 Start screen

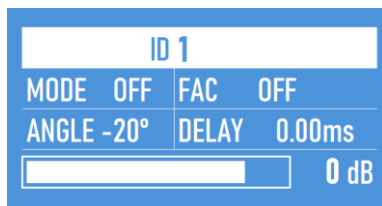

The start screen is displayed as soon as the device has completed the switch-on routine. Press the BACK button to return to the start screen from a submenu.

You can adjust the input sensitivity by turning the **Push For DSP** control.

Adjustable parameters: -80db to +12db

#### 4.1.2 Main menu

<b>HPF</b>	70Hz
ALC	OFF
FAC	OFF
MUTE	OFF
DELAY	0.00ms
TEST VOL	0dB
RESET	
INFO	0.05
ID	1
AOD	OFF

Pressing the **Push For DSP** control opens the main menu. You can access all submenus via the main menu.

The current menu position is highlighted in white. The white bar on the right-hand side indicates which area of the main menu you are in.

**4.1.3 Submenu**

HPF	70Hz
ALC	OFF
FAC	OFF
MUTE	OFF

**HPF** stands for High Pass Filter

Adjustable parameters: 70Hz - 120Hz

HPF	70Hz
ALC	4-6a
FAC	OFF
MUTE	OFF

**ALC** - Array Length Correction

Compensate the mid-range frequencies boost as the number of tops used increases

Adjustable parameters:

- 4 - 6a when using 4-6 tops
- 4 - 6b when using 4-6 tops
- 7 - 9a when using 7-9 tops
- 7 - 9b when using 7-9 tops
- 10 - 12 a when using 10-12 tops
- 10 - 12 b when using 10-12 tops
- 13+ a when using 13 or more L-208 TA
- 13+ b when using 13 or more L-208 TA
- 13+ c when using 13 or more L-208 TA

HPF	70Hz
ALC	OFF
FAC	1
MUTE	OFF

**FAC** - Field Ambience Correction

Compensate the high-range frequencies attenuation caused by increasing humidity and temperature

Adjustable parameters: 1 - 15

HPF	70Hz
ALC	OFF
FAC	OFF
MUTE	ON

**MUTE**

Mutes the input signal

Adjustable parameters: OFF / ON

DELAY	0.00ms
TEST VOL	0dB
RESET	
INFO	0.0.5

**DELAY**

Adjustable delay for runtime correction

Adjustable parameters: 0.00ms - 170.00ms

DELAY	0.00ms
TEST VOL	◀ 0dB
RESET	
INFO	0.0.5

### TEST VOL

Adjustable volume of the loudspeaker test signals. The test signal is activated by pressing the BACK button for 5 seconds.

Adjustable parameters: 0dB to -18dB



### WARNING

The test signal can be very loud and cause hearing damage

DELAY	0.00ms
TEST VOL	0dB
RESET	
INFO	0.0.5

### RESET

Resets all parameters to factory settings.

Adjustable parameters: NO / YES

Security enquiry

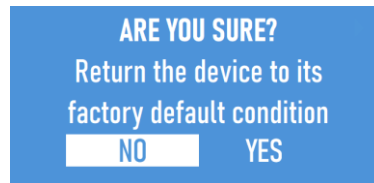

NO: back to the submenu  
 YES: Factory settings are loaded

DELAY	0.00ms
TEST VOL	0dB
RESET	
INFO	0.0.5

### INFO

Firmware version of the device. Can be updated with the P.sys.MANAGER software.

RESET	
INFO	0.0.5
ID	1 ▶
AOD	OFF

### ID

The identification number is used to assign the loudspeaker in the system. It must be set manually on the loudspeaker.

Adjustable parameters: 1 - 64

RESET	
INFO	0.05
ID	1
AOD	◀ 5Min ▶

## AOD

Auto Off Display switches the display off after the preset time

Adjustable parameters: OFF / 5 min. - 30 MIN.

## 4.2 XANA L-118 SA

### 4.2.1 Start screen

ID 2			
DELAY	0.00ms	ANGLE	0°
	NORMAL	HPF	30Hz
			0 dB

The start screen is displayed as soon as the device has completed the switch-on routine. Press the BACK button to return to the start screen from a submenu.

You can adjust the input sensitivity by turning the **Push For DSP** control.

Adjustable parameters: -80db to +12db

### 4.2.2 Main menu

<b>LPF</b>	40Hz
MODE	NORMAL
HPF	30Hz
MUTE	OFF
DELAY	0.00ms
POLARITY	0°
TEST VOL	0dB
RESET	
INFO	1.0.0
ID	2
AOD	OFF

Pressing the **Push For DSP** control opens the main menu. You can access all submenus via the main menu.

The current menu position is highlighted in white. The white bar on the right-hand side indicates which area of the main menu you are in.

### 4.2.3 Submenu

LPF	40Hz ▶
MODE	NORMAL
HPF	30Hz
MUTE	OFF

**LPF** stands for Low Pass Filter

Adjustable parameters: 40Hz - 120Hz

LPF	40Hz
MODE	NORMAL
HPF	30Hz
MUTE	OFF

**MODE**

is used to set the cardioid function.

Adjustable modes: NORMAL  
CARDIOID FRONT  
CARDIOID REAR

LPF	40Hz
MODE	NORMAL
HPF	30Hz
MUTE	OFF

**HPF** stands for High Pass Filter

Adjustable parameters: 30Hz - 120Hz

LPF	40Hz
MODE	NORMAL
HPF	30Hz
MUTE	ON

**MUTE**

Mutes the input signal

Adjustable parameters: OFF / ON

DELAY	0.00ms
POLARITY	0°
TEST VOL	0dB
RESET	

**DELAY**

Adjustable delay of the playback signal

Adjustable parameters: 0.00ms - 170.00ms

DELAY	0.00ms
POLARITY	0°
TEST VOL	0dB
RESET	

**POLARITY**

Adjustable phase position

Adjustable parameters: 0° and 180°

DELAY	0.00ms
POLARITY	0°
TEST VOL	0dB
RESET	

**TEST VOL**

Adjustable volume of the loudspeaker test signals. The test signal is activated by pressing the BACK button for 5 seconds.

Adjustable parameters: 0dB to -18dB



**WARNING**

The test signal can be very loud and cause hearing damage

DELAY	0.00ms
POLARITY	0°
TEST VOL	0dB
<b>RESET</b>	

**RESET**

Resets all parameters to factory settings.

Adjustable parameters: NO / YES

Security enquiry

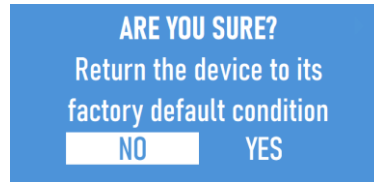

NO: back to the submenu  
YES: Factory settings are loaded

<b>RESET</b>	
INFO	1.0.0
ID	2
AOD	OFF

**INFO**

Firmware version of the device. Can be updated with the P.sys.MANAGER software.

<b>RESET</b>	
INFO	1.0.0
ID	2
AOD	OFF

**ID**

The identification number is used to assign the loudspeaker in the system. It must be set manually on the loudspeaker.

Adjustable range: 1 - 64

<b>RESET</b>	
INFO	1.0.0
ID	2
AOD	5Min

**AOD**

Auto Off Display switches the display off after the preset time

Adjustable range: OFF / 5 min. - 30 MIN.

## 5 P.sysMANAGER - Software



The P.sysMANAGER software was specially designed to control the XANA line array systems and runs under Microsoft Windows® 10 or later .

The "Pronomic USB-RS485 Interface for P.sysManager" Art.No.00108696 is required for the connection between the computer and the loudspeakers.

The software gives you access to all the parameters of each individual speaker connected to the interface. Additional functions such as EQ, grouping etc. are also available.

For convenient system planning, the software also works offline (without connected devices) so that configurations can be saved as projects before installation.

You can download the software under the link: <https://www.kirstein.de/Xana>

## 6 EASE Focus 3 - Software

The EASE Focus 3 software is available for acoustic and mechanical simulation of the XANA line array system.

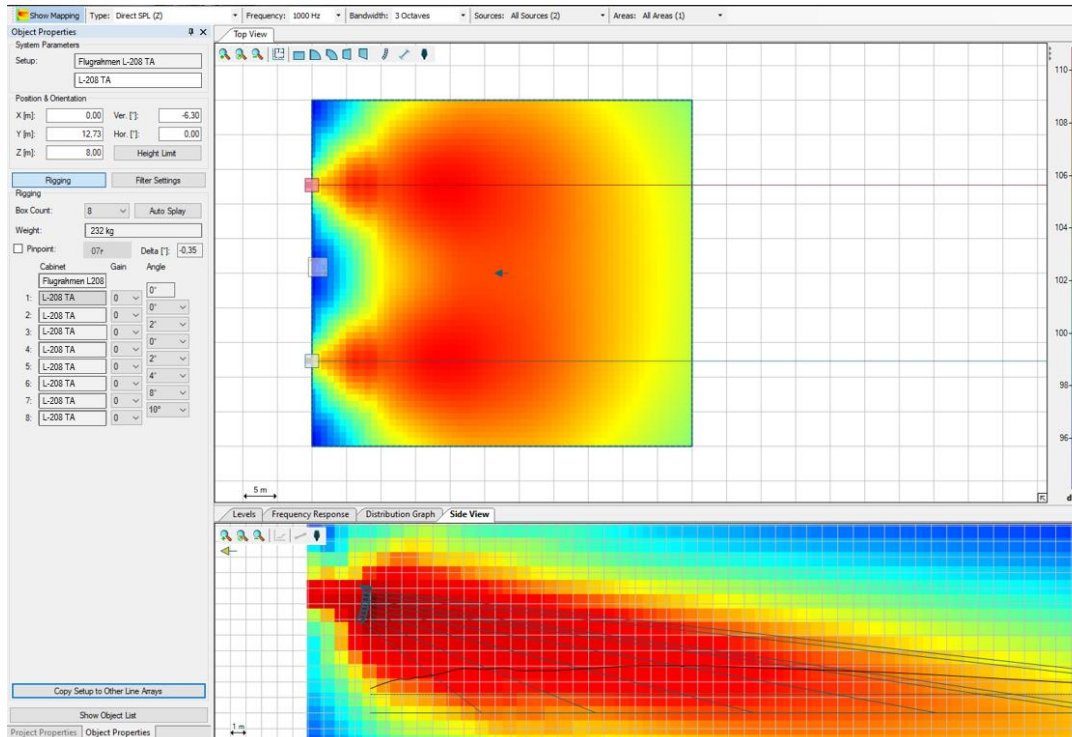

### Using EASE Focus 3

You can download the software free of charge from <https://www.afmg.eu/en/ease-focus>. The software can be used to easily determine how the XANA line array speakers need to be tilted and angled in order to achieve optimum sound distribution in the audience area. Please observe all warnings displayed during use and always check the plausibility of the simulation results.

You can download the XANA simulation data for use in EASE Focus via the following link: <https://www.kirstein.de/Xana>



If the software issues a warning, the system is mechanically overloaded. The system must not be flown in this configuration under any circumstances. In such a case, adjust the configuration so that the warning disappears.

## Optimum alignment of the line array system

Use the "Auto-Splay function" of the software to determine the required angle settings. The lowest unit of the array should be just above the head height of the people standing on the stage. This allows the entire system to be operated with only slight angles between the individual elements - a decisive advantage for acoustic coupling (cylindrical wave principle).



### Important notes on security and system configuration

Also pay attention to the permissible loads listed in the following **section 7 "Load limits"**. Even minor deviations in the overall inclination or angle configuration can significantly affect both, the physical load limits and the acoustic result.

## 7 Load limits

The products and accessories in the XANA Line Array series have been designed in accordance with the guidelines of DGUV regulation 17 (BGV-C1) with a minimum breakage safety factor of 1:3.75.

Up to 16 L-208TA tops can be flown on the XANA L-208TA Flying Frame. The XANA L-118SA Flying Frame allows up to 8 L-118SA subwoofers or a combination of 2x L-118SA subwoofers and a maximum of 12x L-208TA tops to be flown.

However, the actual number of units permitted depends on the downtilt of the array and the pickpoint used. The downtilt itself depends on:

- the length of the array
- the position of the pickpoint and
- the angulation of the individual XANA elements.

As the Flying Frame is always connected to the uppermost top section or subwoofer at an angle of 0°, the inclination of the frame automatically corresponds to the inclination of the uppermost element. **Note:** For a 0° alignment of the uppermost top section L-208TA on the flying frame, the LINK pin must be set at 2°.

**Important note on planning**

Before installation, it is recommended to simulate the desired system configuration using the EASE Focus 3 software.

The maximum possible loads can be found in the table below. If the software nevertheless issues a warning, the system is mechanically overloaded. The system must not be flown in this configuration under any circumstances. In such a case, adjust the configuration so that the warning disappears.

**7.1 XANA L-208 TA flying frame incl. flybar**

Load specifications apply to the flybar in the **'normal'** and **'invers'** positions

Hanging point (pick point)	Max. permissible number Tops L-208 TA
<b>1 - 12</b>	16
<b>13</b>	15
<b>14</b>	14
<b>15</b>	12
<b>16</b>	10

## 7.2 XANA L-118 SA flying frame incl. flybar

### 7.2.1 Flybar in position “normal”

Hanging point (pick point)	Max. permissible number Tops L-208 TA	Max. permissible number Subwoofer L-118 SA	Max. permissible combination of 2x subwoofers L-118 SA + number of L-208 TA tops
1	9	3	+ 3
2	15	4	+ 4
3	16	5	+ 6
4	16	5	+ 8
5	16	8	+ 12
6	16	8	+ 12
7	16	8	+ 12
8	16	8	+ 12
9	16	8	+ 12
10	15	8	+ 12
11	14	8	+ 12
12	13	8	+ 12
13	12	6	+ 11
14	12	5	+ 7
15	10	4	+ 4
16	6	3	+ 3

**7.2.2 Flybar in position “invers”**

Hängepunkt (Pickpoint)	Max. zulässige Anzahl Topteile L-208 TA	Max. zulässige Anzahl Subwoofer L-118 SA	Max. zulässige Kombination aus 2x Subwoofer L-118 SA + Anzahl Topteile L-208 TA
1	10	3	+ 3
2	11	4	+ 4
3	12	6	+ 6
4	14	5	+ 8
5	15	8	+ 12
6	16	8	+ 12
7	16	8	+ 12
8	16	8	+ 12
9	16	8	+ 12
10	16	8	+ 12
11	16	8	+ 12
12	16	8	+ 12
13	15	6	+ 11
14	14	5	+ 7
15	11	4	+ 4
16	10	3	+ 3

## 8 Assembly

### 8.1 Connections

#### 8.1.1 Locking pin with locking mechanism

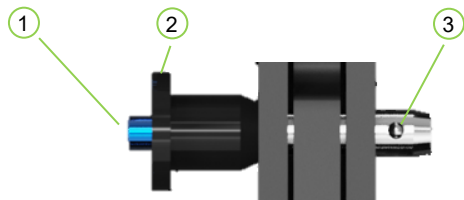

No.	Description of the
-----	--------------------

- |   |               |
|---|---------------|
| 1 | Spring button |
| 2 | Retaining rim |
| 3 | Locking       |

Press and hold the spring button during the insertion process. As soon as the bolt is fully inserted, release the spring button. Make sure that it then pops out again completely and the plug-in bolt is locked in place.



#### WARNING

Do not use force! If handled correctly, all connection points are easy to move!

Never plug or unplug connections under load.

Always ensure that all the connection points described have been established and securely connected.

### 8.1.2 Connecting bolt with safety split pin

There is a groove in the centre of the flying frame (1.) into which the flybar (2.) must be inserted. Make sure that the "FRONT" marking on the flybar points to the "FRONT" marking on the flying frame. Insert the flybar (2.) so deeply into the flying frame (1.) that the two connection openings (3.) are parallel to each other. Now insert the connecting bolt (4.) through the connecting opening (3.). Then secure the connecting bolt (4.) with the safety split pin (5.) to prevent it from falling out.

Proceed with the "REAR" connection in the same way as the "FRONT" connection

The flybar can also be used 'inversely'. In some situations, the flybar needs to be rotated by 180° (mounted inversely). In this case, the 'FRONT' marking on the flybar points towards the 'REAR' of the airframe.

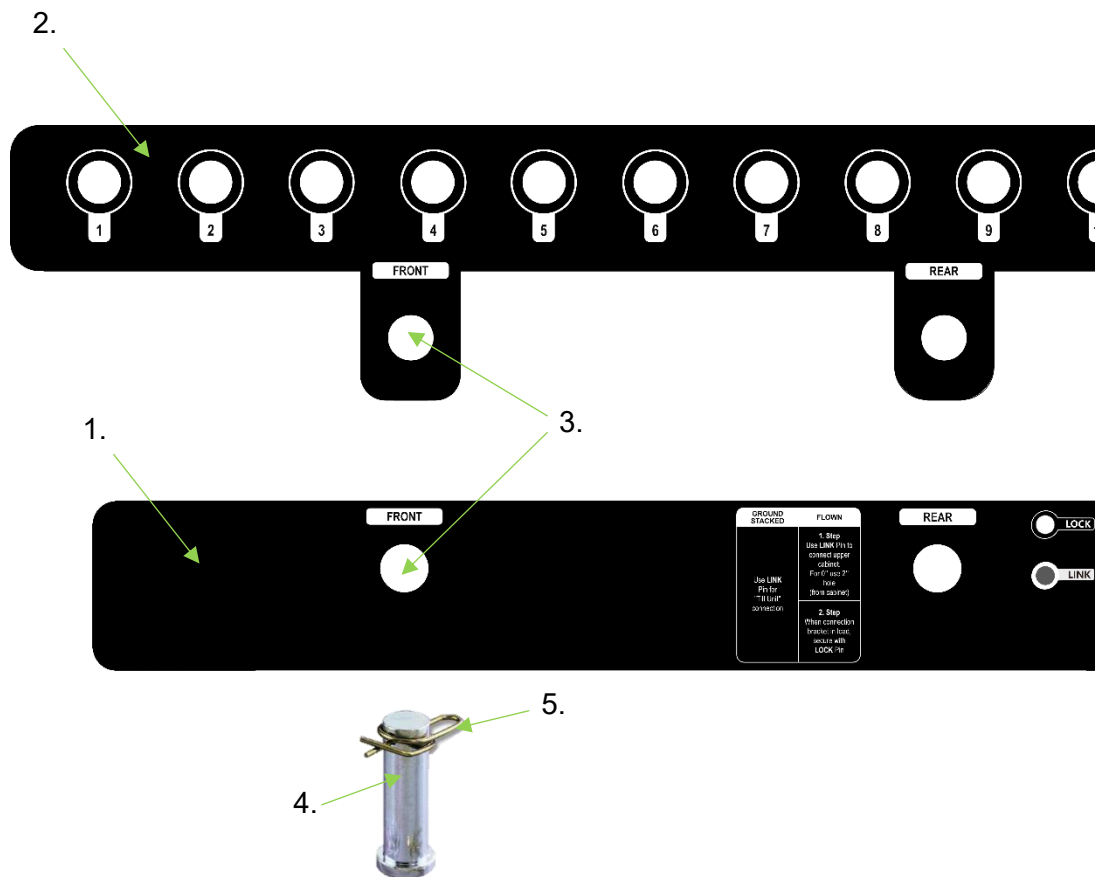

Check that the connecting bolts and safety cotter pins are correctly and securely seated before each use!

**8.2 Transport dolly**

**8.2.1 Adjusting the base plate**

First decide how many tops you want to transport on the dolly. You have the option of stacking either 4 or 6 elements.

There are two tilt positions for the base plate

To adjust the tilt, remove the two pins on the long side of the dolly. Tilt the base plate to the desired position using the illustrations and fix the plug pin in the corresponding hole.

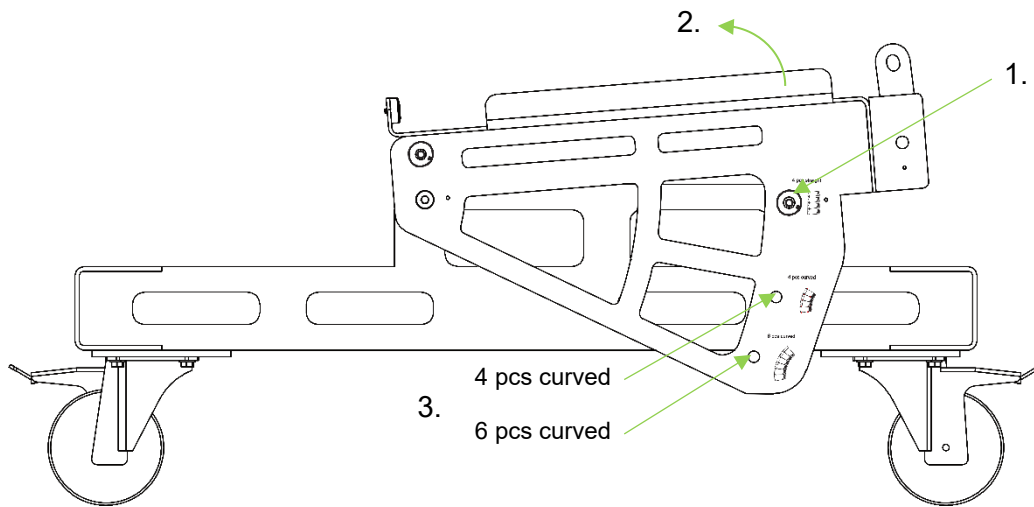

4 pcs curved

6 pcs curved

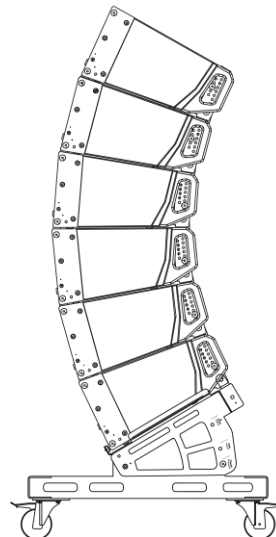
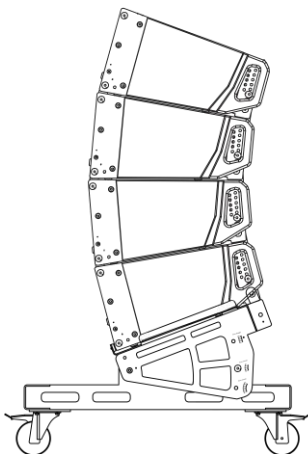

Info: There is a third position for stacking the tops with a fixed 0° angle. To do this, please follow the steps in the "Ground stack" section

### 8.2.2 Fixing the top section to the base plate

- Lift the first top section (1.) flush with the front grille onto the base plate and remove the two plug-in bolts (2.) at the front end of the base plate.
- Then remove the front plug-in bolts of the top section (3.), causing the connecting slide (4.) to slide downwards out of the housing. Secure the slide directly with these plug-in bolts (3.) in the same plug-in position.
- Then make the connection with the hole in the connecting slide by inserting the pins (2.) of the base plate back into position.
- Remove the LINK pin (5.) on the back of the top section. You can then fold the rear hinged bracket of the base plate (6.) upwards and secure it to the top section (5.) using the LINK pin.

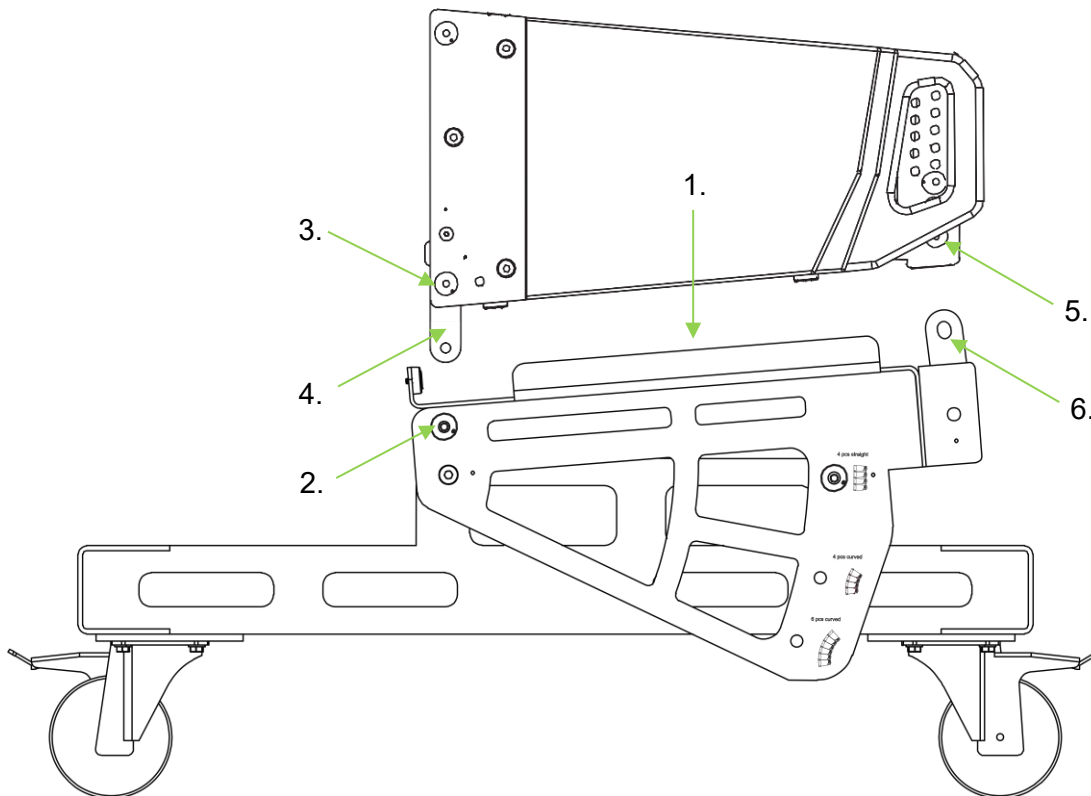

### 8.2.3 Fixing top section to top section

- Lift the next top section flush with the front grille onto the previous top section so that the rubber feet engage in the recesses (1.).
- Then remove the front plug-in bolts (3.) of the top section, allowing the connecting slide (4.) to slide downwards out of the housing. Secure the connecting slide directly with these plug-in bolts (3.) in the same plug-in position.
- Then make the connection with the hole in the connecting slide by inserting the rear pins (5.) of the top section into the holes on the top of the top section underneath (6.), where the ends of the connecting slides are also inserted.
- Remove the LINK pin (7.) on the back of the top section. Now push the load bar (8.) of the lower top section upwards until it touches the LOCK pin (9.) of the upper top section.
- The load bracket can be fixed in this position with the LINK pin (7.).
- Repeat this step according to the number of top sections set.

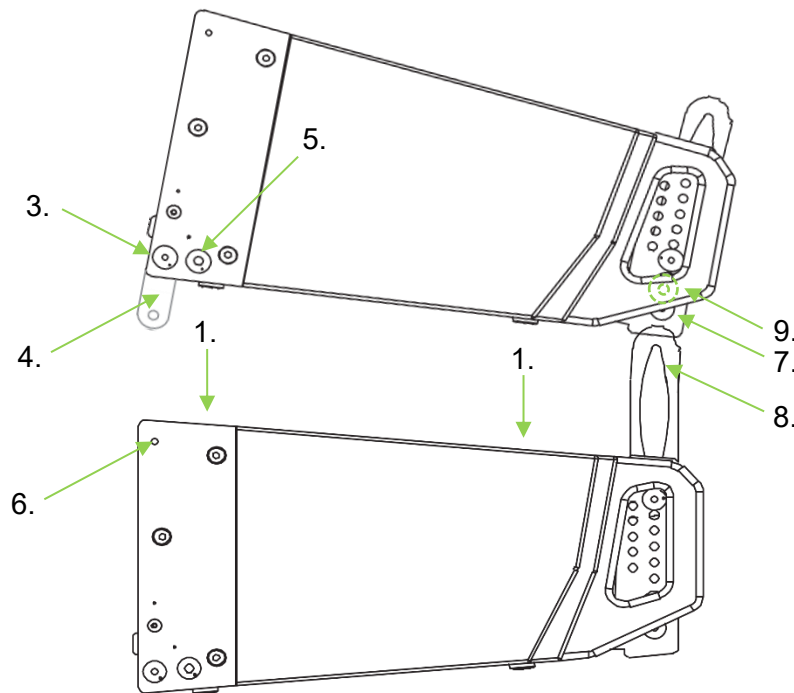

### 8.3 Ground stack

#### 8.3.1 Fixing subwoofer to subwoofer

- Lift the subwoofer flush with the front grille onto the lower subwoofer so that the rubber feet (1.) engage in the recesses. Two people are required for this.
- Remove the lower four plug-in bolts of the upper subwoofer (3.), the connecting slide (4.) will slide downwards out of the housing. Secure the connecting slide (4.) directly in the upper holes of the lower subwoofer (2.) using the same plug-in bolts (3.).
- Repeat this step for several subwoofers if necessary.

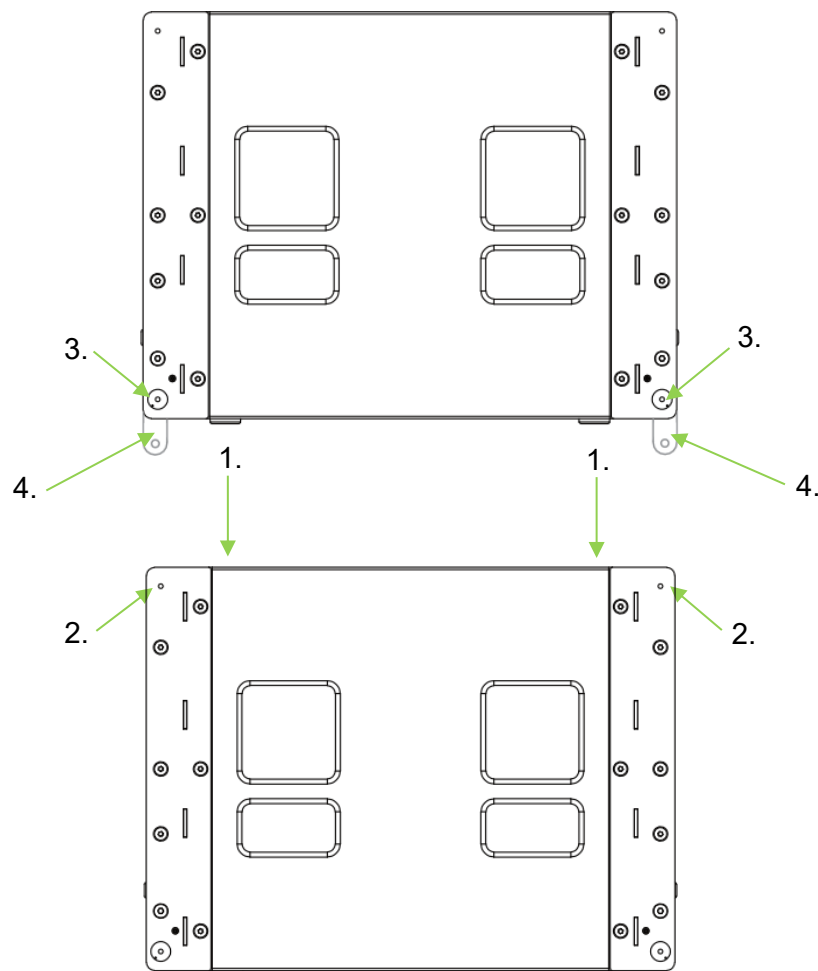

### 8.3.2 Flying frame on subwoofer

#### 8.3.2.1 Using the Xana L-118 SA flying frame

- Remove the four lower pins (1.) at the corners of the flying frame. The connecting slides (4.) with slotted hole fold out of the frame. Then push the socket pins (1.) back into their parking position.
- Remove the upper plug pin (2.) at each corner and slide the connecting slide along the slotted hole towards the position where the upper plug pin (2.) was and fix the slide there.
- Lift the flying frame flush with the outer edges onto the subwoofer. Use the labelling to ensure the correct orientation (top/bottom; front/rear). The instructions are located on the back of the frame.
- Then fix the flying frame to the subwoofer by inserting the parked lower four plug-in bolts (1.) of the flying frame into the upper four holes of the flying frame (5.) (through the connecting slide).

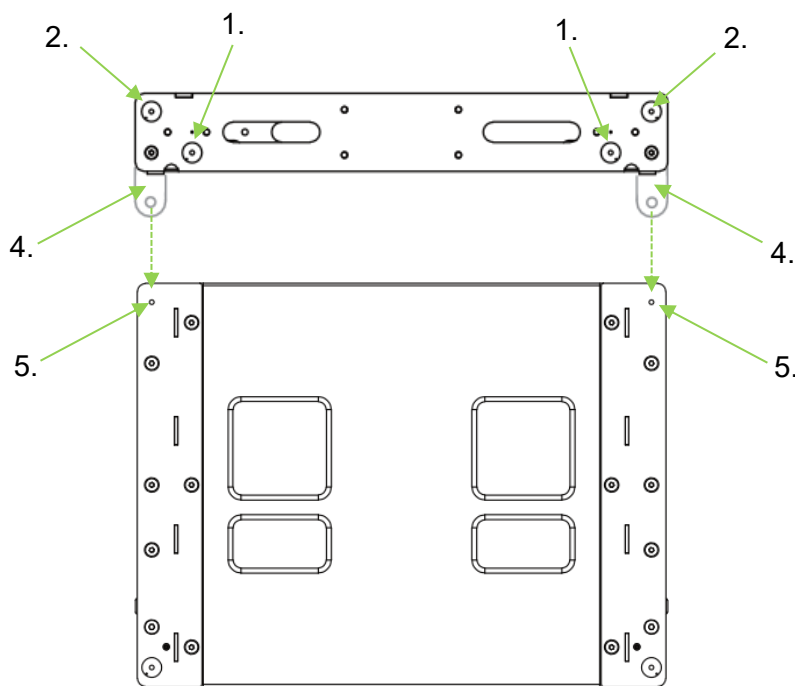

### 8.3.2.2 Using the Xana L-208 SA flying frame with standbase

- Screw the standbase (1.) (accessory item XANA standbase for L-208TA flying frame art. no. 0011195) into the M20 thread (2.) of the upper subwoofer and open the two plug-in bolts of the standbase (5.).
- Lift the flying frame (3.) onto the subwoofer, so that the steel plate of the standbase is in the centre of the flying frame in the gap between the two centre struts (4.). Use the labelling to ensure the correct alignment (top/bottom; front/rear). The connecting slides of the flying frame remain in the park position.
- Move the flying frame back and forth on the subwoofer until the hole pattern in the flying frame matches the hole pattern in the standbase. Now secure the flying frame to the standbase using the two plug-in bolts (5.).

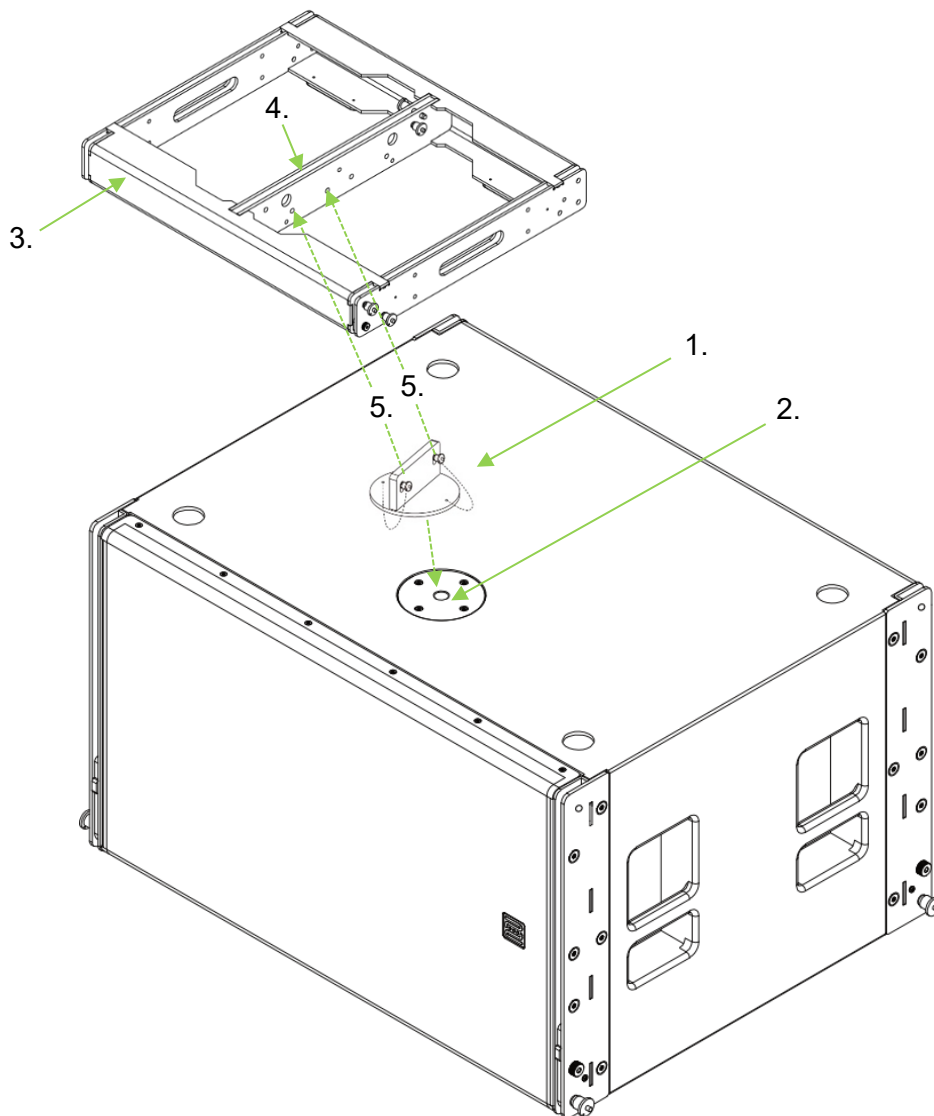

### 8.3.3 Fixing the top section to the flying frame

- Insert the tilt unit (1.) (accessory item no. 0011194) at the position of the LINK pin (2.) so that the toothed side is facing the front.
- Lift the first top flush with the front grille onto the flying frame.
- Remove the two front pins (3.) on the flying frame.
- Then remove the front plug-in bolts of the top section (4.), causing the connecting slide (5.) to slide downwards out of the housing. Then secure the connecting slide again directly with the plug-in bolts (4.) in the same plug-in position.
- Now connect the top section to the flying frame by pushing the front plug-in bolts (3.) of the flying frame back into position.
- Now remove the LINK pin (6.) on the back of the top section. Fold the tilt unit (1.) upwards and connect the tilt unit to the top section by inserting the LINK pin through the hole with the desired angle.

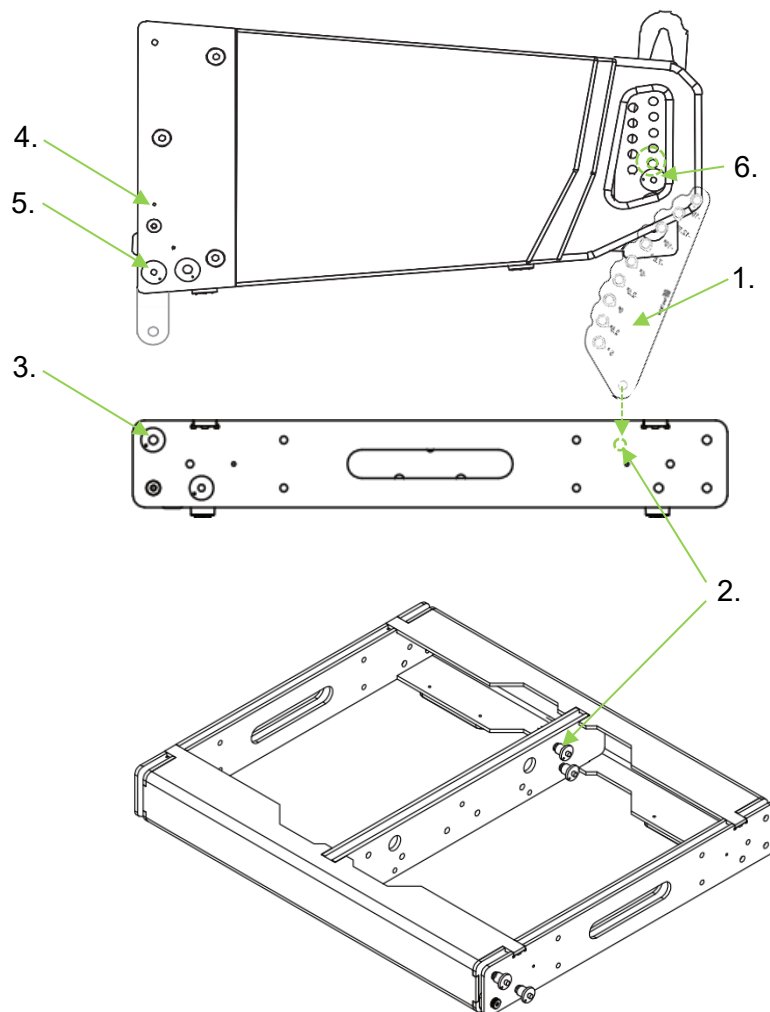

### 8.3.4 Fixing the top section to the top section

- Lift the next top section flush with the front grille onto the previous top section so that the rubber feet engage in the recesses (1.).
- Then remove the front plug-in bolts (3.) of the top section, allowing the connecting slide (4.) to slide downwards out of the housing. Secure the connecting slide directly with these plug-in bolts (3.) in the same plug-in position.
- Then make the connection with the hole in the connecting slide by inserting the rear plug pins (5.) of the top section into the holes on the top of the top section below (6.), where the ends of the connecting slides are also inserted.
- Remove the LINK pin (7.) on the back of the top section. Now push the load bar (8.) of the lower top section upwards, until it touches the LOCK pin (9.) of the upper top section.
- To set the desired angle, lift the top section sideways by the handles until the groove in the load bracket matches the desired angle on the scale on the right-hand side of the mounting rail.
- Then insert the connecting pin (10.) from the left-hand side of the mounting rail through the hole with the desired angle
- Repeat this step according to the number of top sections set.

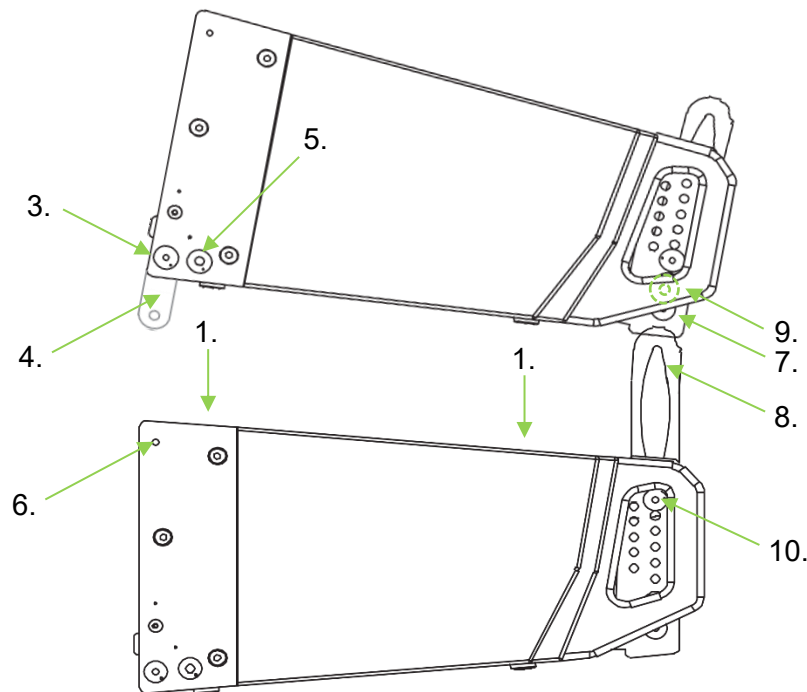

## 8.4 Flown system without subwoofer

### 8.4.1 Fixing the flying frame to top sections with transport dolly

- Remove the two lower pins (1.) on the left and right at the front corners of the flying frame. The connecting slides (2.) with slotted hole fold out of the frame. Then push the locking pins (1.) back into their park position.
- Remove the upper plug pin (3.) at the front corners. Slide the connecting slide along the slotted hole towards the position where the upper plug pin (3.) was and fix the slide there.
- Now lift the flying frame with these connecting slides flush to the front into the corresponding grooves of the top section (4.)
- Fix the connecting slides (2.) through the upper holes on the front of the top section (4.) with the lower plug-in bolts (1.) of the flying frame.
- Remove the rear LINK pin (5.) of the flying frame
- Now push the load bar (6.) of the uppermost top section upwards until it touches the LOCK pin (7.) of the flying frame.
- The load bracket (6.) can be fixed in this position with the LINK pin (5.).
- Now remove the LOCK pins (8.) from all top units on the transport dolly. The LINK pins (10.) always remain inserted.
- To set the desired angle, remove the angle pin (9.) from the top section underneath and slide the load bracket (6.) upwards, until the groove in the load bracket matches the desired angle on the scale on the right-hand side of the mounting rail
- Then insert the angle pin (9.) from the left-hand side of the mounting rail through the hole with the desired angle
- Repeat this step accordingly with the next top sections.

#### NOTE

To connect the uppermost top section to the flying frame, set ALWAYS set 2° to achieve a 0° angle. Follow the instructions on the flying frame!

- Now remove the three plug-in bolts (11.) that secure the top sections on the transport dolly.
- You can now lift the tops out of the dolly. This will automatically create the set angles.
- As soon as the array is under load, put all the LOCK pins (8.) back into position to lock the brackets in place.

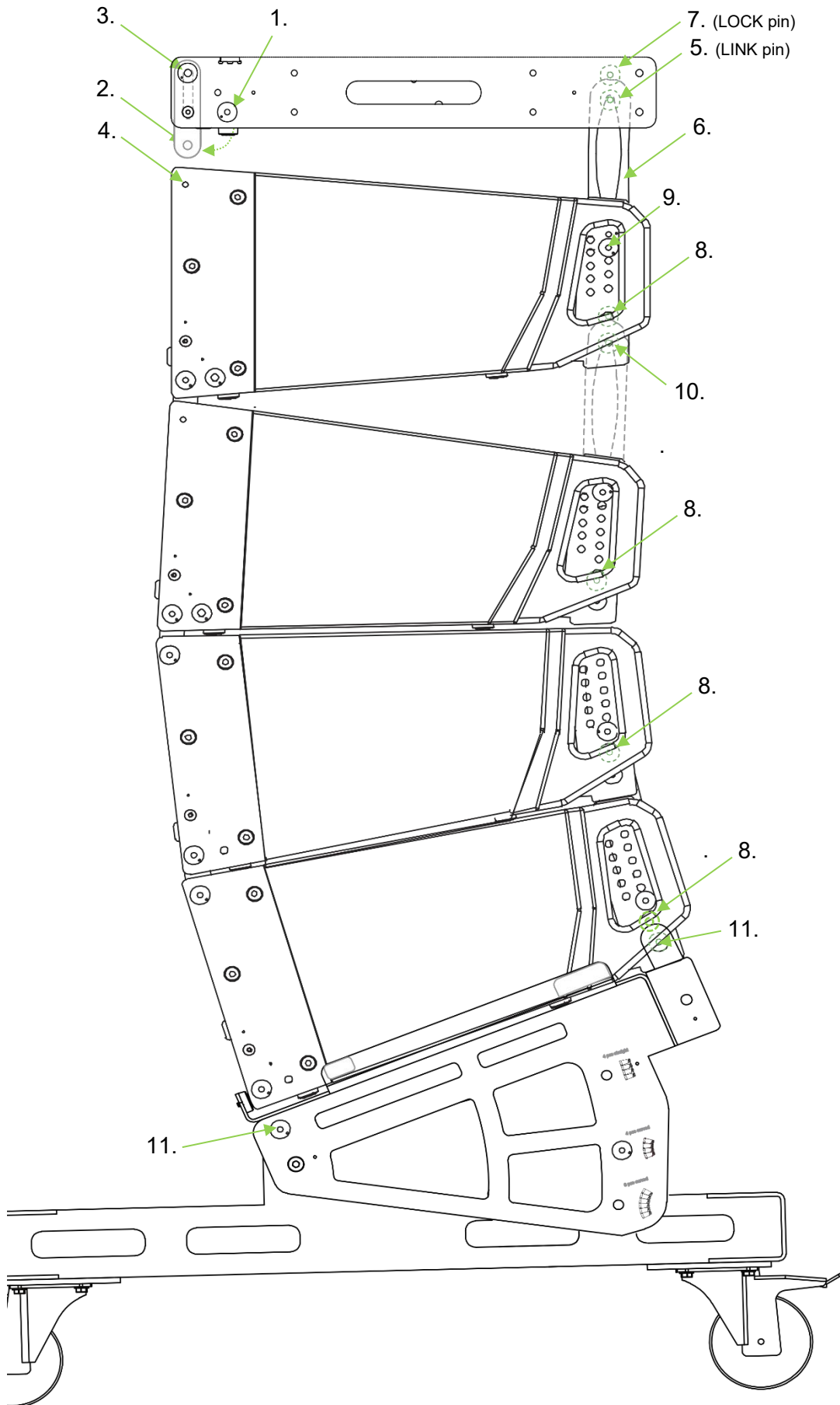

#### 8.4.2 Fixing flying top section on top section with transport dolly

- Remove the front plug-in bolts (1.) from the bottom top section of the array. The connecting slide (2.) will slide downwards out of the housing. Secure the slide directly with the plug-in bolts (1.) in the same plug-in position.
- Now lift the array with these connecting slides flush to the front into the corresponding grooves of the top section of the next transport dolly.
- Then make the connection with the hole in the connecting slide by inserting the rear pins (3.) of the lowest suspended top section into the holes (4.) on the top of the top section below, where the ends of the connecting slides (2.) are also inserted.
- Remove the LINK pin (5.) of the lowest suspended top section
- Now push the load bar (6.) of the topmost top section on the transport dolly upwards until it touches the LOCK pin (7.) of the lowest suspended top section.
- The load bracket (6.) can be fixed in this position with the link pin (5.).
- Now remove the LOCK pins (8.) from all tops on the transport dolly. The LINK pins always remain inserted.
- To set the desired angle, remove the angle pin (9.) from the top section underneath and slide the load bracket (10.) upwards, until the groove in the load bracket matches the desired angle on the scale on the right-hand side of the mounting rail (for details, see chapter 3.1.1)
- Then insert the angle pin (11.) from the left-hand side of the mounting rail through the hole with the desired angle
- Repeat this step accordingly with the next top sections.
- Now remove the three pins (12.) that secure the top sections on the transport dolly.
- You can now lift the tops out of the dolly. This will automatically create the set angles.
- As soon as the array is under load, put all LOCK pins (8.) back into position to lock the brackets.

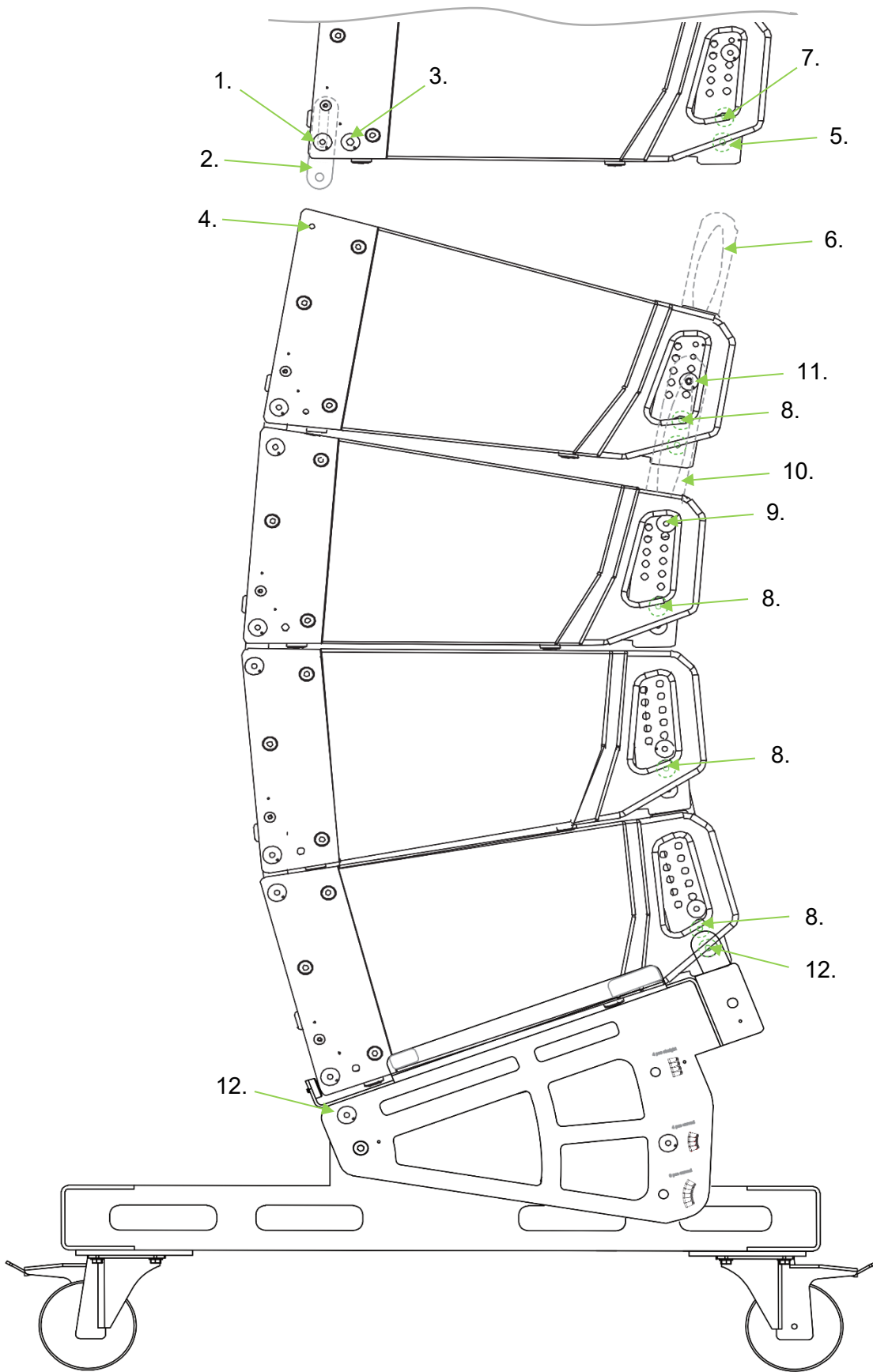

## 8.5 Flown system with subwoofer

### 8.5.1 Fixing the L-118 SA flying frame to the subwoofer

- Remove the four lower pins (1.) at the corners of the flying frame. The connecting slides (4.) with slotted hole fold out of the frame. Then push the socket pins (1.) back into their parking position.
- Remove the upper plug pin (2.) at each corner and slide the connecting slide along the slotted hole towards the position where the upper plug pin (2.) was and fix the slide there.
- Lift the flying frame flush with the outer edges onto the subwoofer. Use the labelling to ensure the correct orientation (top/bottom; front/rear). The instructions are located on the back of the frame.
- Then fix the flying frame to the subwoofer by inserting the parked lower four plug-in bolts (1.) of the flying frame into the upper four holes of the flying frame (5.) (through the connecting slide).

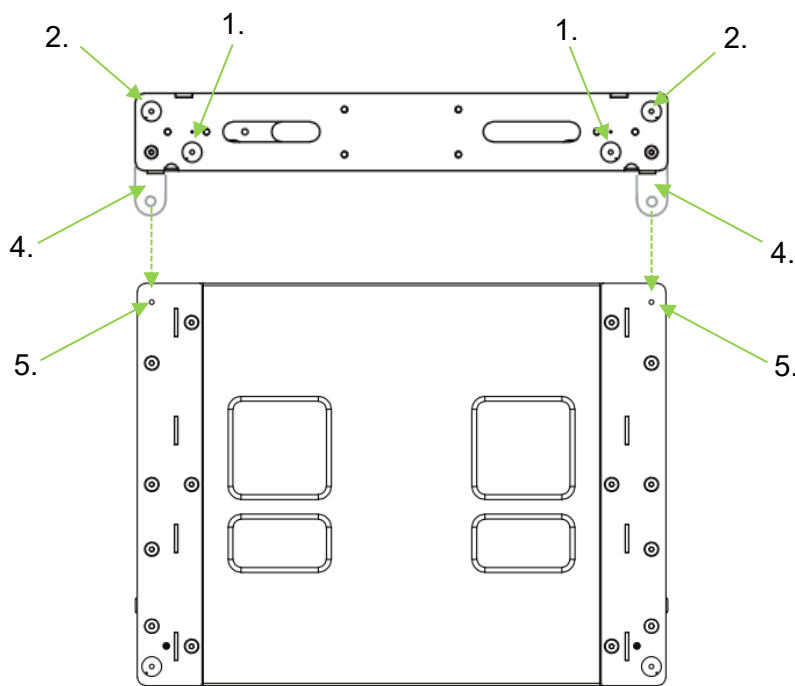

### 8.5.2 Fixing the L-118 SA flying frame under the subwoofer

- Lift the subwoofer(s) flush with the front grille onto the flying frame. Two people or suitable lifting gear are required for this. Use the labelling to ensure the correct orientation (top/bottom; front/rear). The connecting slides (1.) of the flying frame remain in the park position.
- Remove the four upper pins (2.) at the corners of the flying frame.
- Then remove the lower four plug-in bolts (3.) of the subwoofer on the flying frame. The connecting slide (4.) will slide downwards out of the housing. Then push the plug-in bolt (3.) back into its original position.
- Then make the connection with the hole in the connecting slide by inserting the upper pins (2.) of the flying frame back into their position, where the ends of the connecting slides (4.) are also inserted.

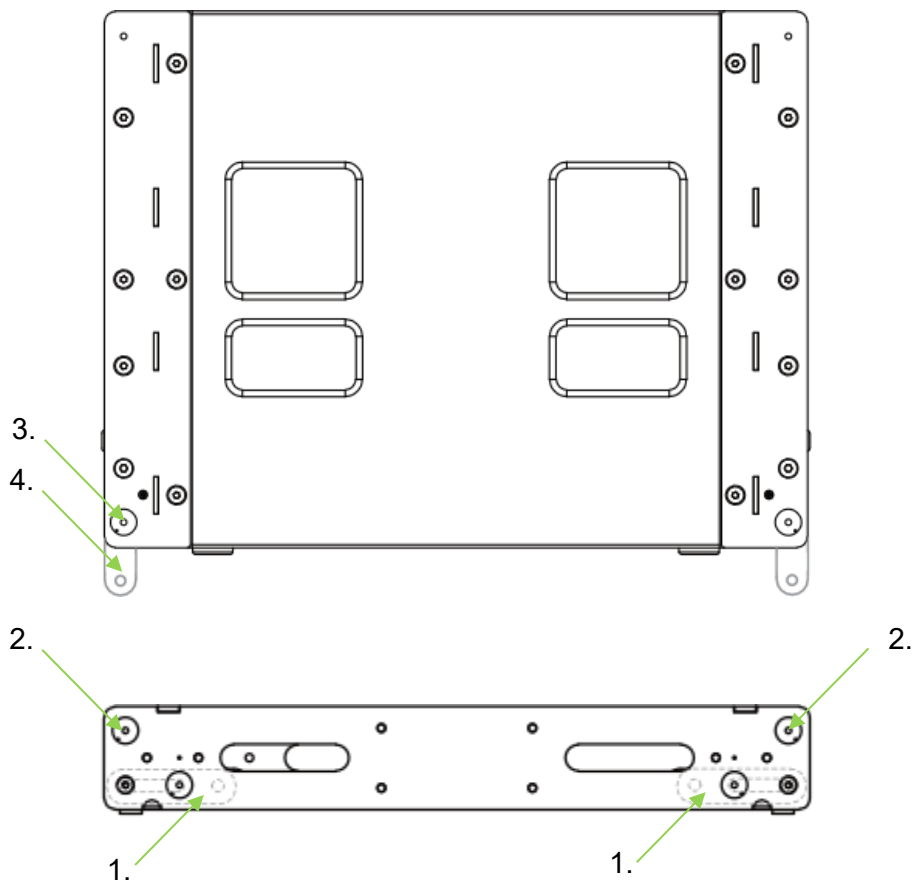

### 8.5.3 Fixing the top section under the L-118 SA flying frame of the transport dolly

- Remove the two internal front plug-in bolts (1.) in the flying frame. The connecting slides (2.) for connecting a top section fold downwards.
- Now lift the array with these connecting slides (2.) into the corresponding grooves (left and right of the front grille) of the top section of the next transport dolly.
- Fix the connecting slides through the upper holes (3.) on the front of the top section with the internal plug-in bolts (1.) of the flying frame.
- Remove the rear internal LINK pin (4.) of the flying frame
- Now push the load bar (5.) of the top section upwards, until it touches the LOCK pin (6.) of the flying frame.
- Now secure the load bracket (5.) with the LINK pin (4.).
- Remove the LOCK pins (7.) from all top sections on the transport dolly. The LINK pins (10.) always remain inserted.
- To set the desired angle, remove the angle pin (8.) from the top section underneath and slide the load bracket (9.) upwards until the groove in the load bracket matches the desired angle on the scale on the right-hand side of the mounting rail
- Then insert the angle pin (8.) from the left-hand side of the mounting rail through the hole with the desired angle
- Repeat this step accordingly with the next top sections.

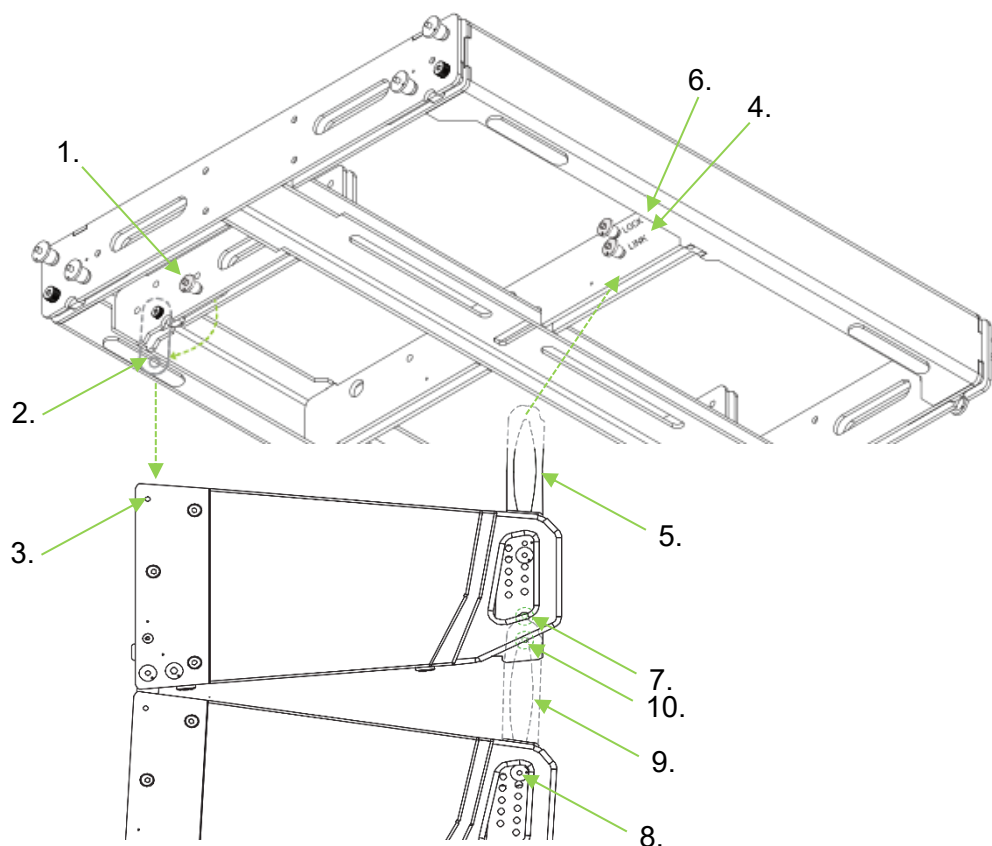

**NOTE**

To connect the uppermost top section to the flying frame, ALWAYS set  $2^\circ$  to achieve a  $0^\circ$  angle.

Follow the instructions on the flying frame!

- Now remove the three plug-in bolts (11.) that secure the top sections on the transport dolly.
- You can now lift the tops out of the dolly. This will automatically create the set angles.
- As soon as the array is under load, put all the lock pins back into position to lock the brackets in place.

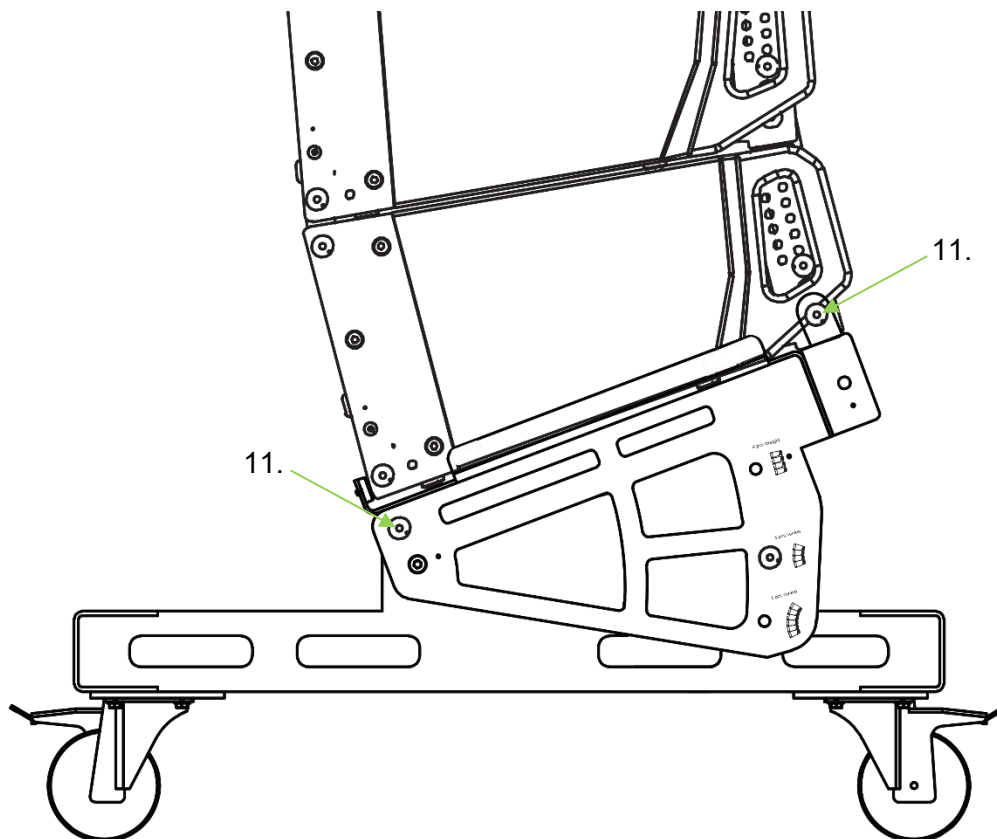

#### 8.5.4 Fixing the top section to the top section of the transport dolly

- Remove the front plug-in bolts (1.) from the bottom top section of the array. The connecting slide (2.) will slide downwards out of the housing. Secure the slide directly with the plug-in bolts (1.) in the same plug-in position.
- Now lift the array with these connecting slides flush to the front into the corresponding grooves of the top section of the next transport dolly.
- Then make the connection with the hole in the connecting slide by inserting the rear pins (3.) of the lowest suspended top section into the holes (4.) on the top of the top section below, where the ends of the connecting slides (2.) are also inserted.
- Remove the LINK pin (5.) from the lowest suspended top section.
- Now push the load bar (6.) of the topmost top section on the transport dolly upwards, until it touches the LOCK pin (7.) of the lowest hanging top section.
- The load bracket (6.) can be fixed in this position with the LINK pin (5.).
- Now remove the LOCK pins (8.) from all tops on the transport dolly. The LINK pins always remain inserted.
- To set the desired angle, remove the angle pin (9.) from the top section underneath and slide the load bracket (10.) upwards, until the groove in the load bracket matches the desired angle on the scale on the right-hand side of the mounting rail (for details, see chapter 3.1.1)
- Then insert the angle pin (11.) from the left-hand side of the mounting rail through the hole with the desired angle
- Repeat this step accordingly with the next top sections.
- Now remove the three pins (12.) that secure the top sections on the transport dolly.
- You can now lift the tops out of the dolly. This will automatically create the set angles.
- As soon as the array is under load, put all LOCK pins (8.) back into position to lock the brackets.

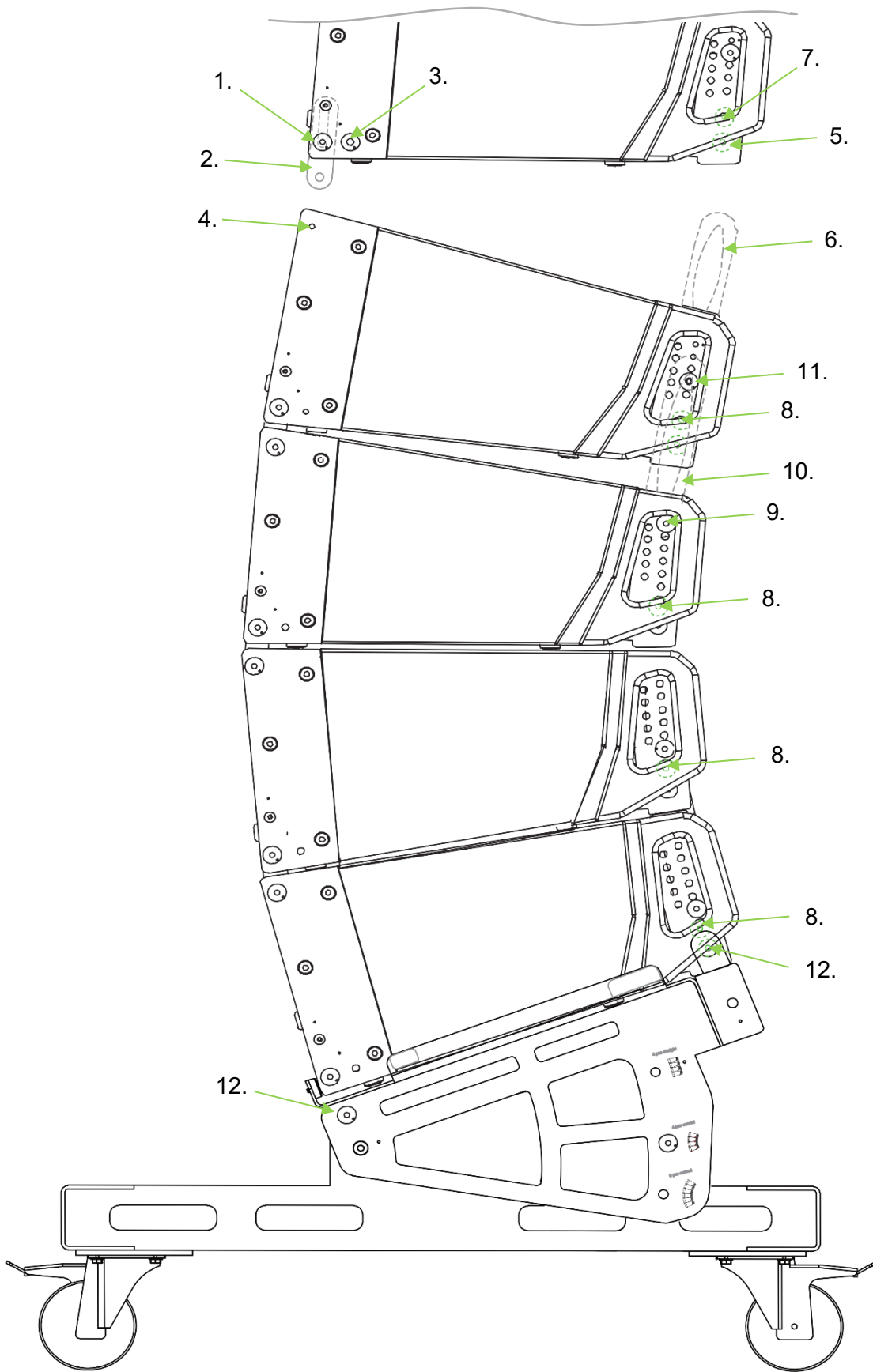

## 9 Specifications

### 9.1 XANA L-208 TA Line Array Top 1,400W

<b>Structure</b>	3-way active
<b>Frequency response</b>	65Hz - 20KHz (-10dB)
<b>Max SPL</b>	132 dB
<b>Loudspeaker</b>	2x 1.35" / 8Ω / CD horn 2x 8" neodymium / 4Ω / 2 "v.c
<b>Beam angle</b>	90° horizontal 12° vertical
<b>Amplifier power</b>	1,400 W RMS 2,800 W peak
<b>Cooling</b>	No fan, convection cooling
<b>Mains voltage</b>	220-240V / 50-Hz
<b>Controller</b>	DSP 32 bit
<b>Network</b>	RS 485 Protocol
<b>LED display</b>	Input signal, limit
<b>Signal connections</b>	Line Input 1x XLR 3-pin female, balanced Line Out 1x XLR 3-pin female, balanced
<b>Network connections</b>	DATA Input Network b. (etherCON compatible) DATA Link Netzwerk b. (etherCON compatible)
<b>Power connections</b>	Mains Input 1x PowerCON TRUE1 Mains Link 1x PowerCON TRUE1
<b>Power consumption</b>	3.7A max. (850W)
<b>Work area</b>	-5°C to 40°C   max. 5,000m above sea level
<b>Housing</b>	Birch plywood with polyurethane coating
<b>Flight system</b>	3 point
<b>Width x height x depth</b>	620 x 250 x 470 mm
<b>Weight</b>	27.5 kg

## 9.2 XANA L-118 SA line array subwoofer 2,800W

<b>Structure</b>	Active line array subwoofer, airborne
<b>Frequency response</b>	34Hz - 150Hz (-10dB)
<b>Max SPL</b>	138 dB
<b>Loudspeaker</b>	1x 18" neodymium / 4Ω / 4" v.c
<b>Amplifier power</b>	2,400 W RMS 4,800 W peak
<b>Cooling</b>	No fan, convection cooling
<b>Mains voltage</b>	220 - 240V / 50Hz
<b>Controller</b>	DSP 32 bit
<b>Network</b>	RS 485 protocol
<b>LED display</b>	Input signal, limit
<b>Signal connections</b>	Line Input 1x XLR 3-pin female, balanced Line Out 1x XLR 3-pin female, balanced
<b>Network connections</b>	DATA Input Network b. (etherCON compatible) DATA Link Netzwerk b. (etherCON compatible)
<b>Power connections</b>	Mains Input 1x PowerCON TRUE1 Mains Link 1x PowerCON TRUE1
<b>Power consumption</b>	10.3A max. (2,360W)
<b>Work area</b>	-5°C to 40°C   max. 5,000m above sea level
<b>Housing</b>	Birch plywood with polyurethane coating
<b>Flight system</b>	4 point
<b>Width x height x depth</b>	840 x 495 x 655 mm
<b>Weight</b>	71.4 kg

### 9.3 XANA L-208 TA flying frame

<b>Structure</b>	Steel construction
<b>Diameter pick point</b>	20mm
<b>Width x height x depth (without pins)</b>	622 x 84 x 520 mm
<b>Weight</b>	15.65 kg

### 9.4 XANA L-118 SA flying frame

<b>Structure</b>	Steel construction
<b>Diameter pick point</b>	20mm
<b>Width x height x depth (without pins)</b>	840 x 85 x 650 mm
<b>Weight</b>	31.81 kg

## 10 Maintenance



**DANGER**

Suspension systems consist of mechanical components and must therefore be regularly inspected and maintained to ensure their proper function and safety.

Before installing a loudspeaker system, it is essential to ensure that all components - such as the housing, flying frame, bolts, locking pins, split pins, etc. - are checked for cracks, deformation, corrosion and missing, loose or damaged parts. Such defects can significantly impair the load-bearing capacity and safety of the entire system.

A loudspeaker must not be suspended or placed on a stand until all necessary measures have been taken to rectify any defects found.

Installed systems must be inspected at least once a year. This inspection should include a visual inspection of all load-bearing components - in particular for cracks, deformation, moisture damage or other signs that could jeopardise the structural integrity of the speaker enclosure. Defective components must not be put into operation.



## 11 Cleaning

Use a lint-free and only slightly damp cloth for cleaning. Chemical cleaners may contain solvents, which can damage the surfaces.

### WEEE declaration (Waste of Electrical and Electronic Equipment)

Your product has been developed and manufactured using high-quality materials and components that are recyclable and reusable. The symbol means that your product must be disposed of separately from household waste at the end of its service life.

Dispose of this appliance at your local collection point or recycling centre.

Please help to protect the environment in which we all live.

All technical data and appearances are subject to change without prior notice. All information was correct at the time of printing. Musikhaus Kirstein GmbH accepts no liability for the accuracy or completeness of the descriptions, photos or statements contained in this manual. Printed colours and specifications may differ slightly from the product. Musikhaus Kirstein GmbH products are only sold through authorised dealers. Distributors and dealers are not representatives of Musikhaus Kirstein GmbH and are not authorised to legally bind Musikhaus Kirstein GmbH in any way.

**Musikhaus Kirstein GmbH**  
**Bernbeurener Street 11**  
**86956 Schongau - Germany**  
**Phone: 0049-8861/909494-0**  
**info@kirstein.de**



## XANA Line Array System



Operating instructions

## Contents

<b>1 Safety instructions and warning symbols .....</b>	<b>1</b>
1.1 General information.....	1
1.2 Intended use .....	1
1.3 Explanation of symbols and terms.....	2
1.4 Safety instructions .....	3
<b>2 Packaging.....</b>	<b>6</b>
2.1 Note .....	6
2.2 Scope of delivery.....	6
<b>3 System components.....</b>	<b>7</b>
3.1 XANA L-208 TA Line Array Top 1,400W .....	7
3.1.1 Mechanics .....	7
3.1.2 Electronics .....	9
3.2 XANA L-118 SA line array subwoofer 2,400W.....	10
3.2.1 Mechanics .....	10
3.2.2 Electronics .....	12
3.3 Accessories.....	13
3.3.1 XANA L-208 TA flying frame incl. flybar .....	13
3.3.2 XANA L-118 SA flying frame incl. flybar .....	14
3.3.3 XANA L-208 TA Transport Dolly .....	15
3.3.4 Other accessories.....	16
<b>4 DSP settings .....</b>	<b>19</b>
4.1 XANA L-208 TA.....	19
4.1.1 Start screen .....	19
4.1.2 Main menu.....	19
4.1.3 Submenu .....	20
4.2 XANA L-118 SA .....	22
4.2.1 Start screen .....	22
4.2.2 Main menu.....	22

4.2.3 Submenu .....	22
<b>5 P.sysMANAGER - Software.....</b>	<b>25</b>
<b>6 EASE Focus 3 - Software .....</b>	<b>26</b>
<b>7 Load limits.....</b>	<b>27</b>
7.1 XANA L-208 TA flying frame incl. flybar.....	28
7.2 XANA L-118 SA flying frame incl. flybar .....	29
<b>8 Assembly.....</b>	<b>30</b>
8.1 Connections .....	31
8.1.1 Locking pin with locking mechanism .....	31
8.1.2 Connecting bolt with safety split pin .....	32
8.2 Transport dolly .....	33
8.2.1 Adjusting the base plate.....	33
8.2.2 Fixing the top section to the base plate.....	34
8.2.3 Fixing top section to top section .....	35
8.3 Ground stack.....	36
8.3.1 Fixing subwoofer to subwoofer.....	36
8.3.2 Flying frame on subwoofer.....	37
8.3.2.1 Using the Xana L-118 SA flying frame.....	37
8.3.2.2 Using the Xana L-208 SA flying frame with stand base .....	38
8.3.3 Fixing the top section to the flying frame .....	39
8.3.4 Fixing the top section to the top section .....	40
8.4 Flown system without subwoofer.....	41
8.4.1 Fixing the flying frame to top sections with transport dolly.....	41
8.4.2 Fixing flying top section on top section with transport dolly .....	43
8.5 Flown system with subwoofer.....	45
8.5.1 Fixing the L-118 SA flying frame to the subwoofer .....	45
8.5.2 Fixing the L-118 SA flying frame under the subwoofer .....	46
8.5.3 Fixing the top section under the L-118 SA flying frame of the transport dolly .....	47
8.5.4 Fixing the top section to the top section of the transport dolly .....	49

<b>9 Specifications .....</b>	<b>51</b>
9.1 XANA L-208 TA Line Array Top 1,400W .....	51
9.2 XANA L-118 SA line array subwoofer 2,800W.....	52
9.3 XANA L-208 TA flying frame .....	53
9.4 XANA L-118 SA flying frame .....	53
<b>10 Maintenance.....</b>	<b>53</b>
<b>11 Cleaning .....</b>	<b>55</b>

© 2025

These operating instructions are protected by copyright. Reproduction of these operating instructions, even in part, is only permitted with the authorisation of Musikhaus KIRSTEIN GmbH. The same applies to the reproduction or copying of images, even in modified form.

Thank you for choosing a product from PRONOMIC. You have made a good choice. PRONOMIC has been synonymous with high-quality audio products at a fair price-performance ratio for many years. You can find more information about the XANA series at <https://www.kirstein.de/Xana> . We wish you many interesting and successful projects using the XANA line array series.

## **1 Safety instructions and warning symbols**

### **1.1 General information**

Please read these operating instructions carefully and completely before using the XANA line array system. Only then, a safe and trouble-free operation is guaranteed.

If any formulations, specifications or procedures in these instructions are unclear to you, do not use the system under any circumstances.

Observe the warnings on the device and in the operating instructions.

Keep these operating instructions in a safe place within easy reach. The operating instructions are an integral part of the product and must be passed on to all subsequent users.

### **1.2 Intended use**

The devices of the Pronomic XANA series have been developed for professional audio applications. Therefore, they are only intended for use by qualified personnel with specialist knowledge. These devices are not suitable for domestic use. Any use outside the described technical data and application conditions is considered improper use!

The products of the XANA Line Array series are not suitable for children and persons with insufficient experience and training. No liability is accepted for damage, including damage to third parties and their property, caused by improper use.

All information in these operating instructions have been checked to the best of our knowledge and belief. However, neither the author nor the publisher can be held liable for any damages related to the use of these operating instructions.

Other product, brand and company names mentioned in this document may be the trademarks of their respective owners. Compliance with all applicable copyright laws is the responsibility of the user of this document.

### 1.3 Explanation of symbols and terms



The manual refers the user to additional information on the product.



The exclamation mark draws the user's attention to important information in the operating instructions that must be observed.



The hearing protection warns the user of the dangers of high volumes.



The flash warns the user of the dangers of electric current and magnetic fields.

#### **DANGER**

Indicates an immediately life-threatening situation. Failure to comply poses an acute danger to life and limb. Can be supplemented by a symbol.

#### **WARNING**

Indicates a potentially hazardous situation which, if not avoided, could result in serious injury or death. Can be supported by a symbol.

#### **NOTE**

The signal word NOTICE indicates general precautionary measures that should be observed when handling the product. Can be supplemented by a symbol.

## 1.4 Safety instructions

These operating instructions apply to persons who have been supervised or instructed in the operation of the appliance by a person responsible for their safety and who have demonstrated that they are able to handle the appliance.



**Children should be supervised to ensure that they do not play with the appliance.  
Do not leave children unattended.**



**DANGER**

Never disassemble your appliance. An incorrectly repaired appliance can be dangerous for the user. If you have any problems, please contact our service centre.

Comply with the trade association regulation "BGV A2 - Electrical systems and equipment".

Do not use the appliance near water (e.g. near a bathtub, washbasin, sink, in a damp cellar or near a swimming pool, etc.).

Check the mains cable for damage before each use. If you notice any damage, the mains cable must be replaced.

The speaker system must not be set up near heat sources such as radiators, fan heaters or other devices that generate heat. The speakers must be protected from direct sunlight, as this can cause the electronics to fail due to overheating.

The appliance may only be connected to a power supply that corresponds to the type described in the operating instructions or indicated on the appliance.

The product should be serviced by qualified service personnel if:

- objects have fallen into the appliance or liquid has been spilled on the appliance
- The device was exposed to rain
- The device does not appear to be functioning normally or there is a significant change in performance
- The device has been dropped or the housing has been damaged
- Do not attempt to service the appliance beyond the measures described in the maintenance instructions. All other maintenance work should be carried out by qualified service personnel.

**WARNING**

This loudspeaker system can generate sound levels that can lead to permanent hearing loss. During operation, ensure that you comply with the legal requirements for accident prevention and the "BGV B3 - Noise" of the employers' liability insurance association.

Do not operate the device at a high volume or at a level that is uncomfortable for a long period of time. If you notice hearing loss or ringing in your ears, you should consult an ear specialist.

Wear hearing protection during operation and do not stand in the immediate vicinity of the speakers.

Never climb on the hanging or standing system.

**NOTE**

Read all instructions before using the product.

Images and screen displays in these operating instructions may differ slightly from the appearance of the actual product as long as this has no negative impact on the technical properties and safety of the product.

All personal formulations in these operating instructions are to be regarded as gender-neutral.

The warranty is void if the product is damaged due to improper use.

Make sure that no objects fall into the openings of the housing and that no liquids penetrate.

Do not cover any ventilation openings.

Protect the speaker system from rain or moisture. The operating temperature range is between +40°C and -5°C.

**DANGER**

Only use the accessories specified by the manufacturer.

Ensure that suitable protective clothing is worn during assembly and dismantling and observe all relevant accident prevention regulations.

During assembly and dismantling, mechanically moving devices and falling parts can pose a considerable risk of injury. Therefore, please observe the relevant trade association regulations:

- DGUV Regulation 54 - "Winches, lifting and pulling equipment"
- DGUV Regulation 1 - "Principles of prevention"
- DGUV Regulation 17 - "Event and production venues for scenic presentation"

DGUV Information 215-313 "Loads above persons" must also be observed.

The mounting accessories supplied with the XANA line array system or specially designed for this purpose must also be checked for wear and functionality at least once a year - or in accordance with applicable local regulations. Particular attention must be paid to signs of corrosion, bending, material fatigue or other impairment of stability.

The respective inspection and maintenance specifications of the manufacturer apply to other slings.

Before any installation, a competent person with experience and training in handling speaker suspension systems should carefully check all components and connections.

The structure is designed for operation in enclosed spaces (exhibition halls, event halls, etc.). Outdoor operation is permitted, provided that the wind loads at the top and bottom ends are transferred horizontally and the structure is lowered at wind speeds above 8 Bft.

All slings must be dimensioned, planned and their installation monitored by specialised personnel in accordance with the explanations in DGUV Information 215-313 (BGI 810-3) on DGUV Regulation 17 (UVV BGV-C1).

All connections must be secured against loosening.

Please refer to the information in IGWV Guideline SQ P1 regarding protective equipotential bonding, lightning protection and defect testing of the components used.

## 2 Packaging

### 2.1 Note



Open the shipping carton carefully and check for visible damage. Each PRONOMIC XANA Series device is fully tested and inspected before leaving the factory and should arrive in perfect condition. If you notice any damage, notify the shipping company immediately. Save the carton and all packing materials for inspection by the carrier.

### 2.2 Scope of delivery

#### XANA L-208 TA Line Array Top

- 1x L-208 TA Line Array top unit
- 1x operating instructions
- 1x mains cable

#### XANA L-118 TA Line Array Subwoofer

- 1x L-118 SA line array subwoofer
- 1x operating instructions
- 1x mains cable

#### XANA flying frame L-208 TA and L-118 SA

- 1x flying frame
- 1x flybar
- 1x operating instructions

#### XANA L-208 TA and L-118SA Transport Dolly

- 1x transport dolly
- 4x swivel castor
- 1x operating instructions

### 3 System components

#### 3.1 XANA L-208 TA Line Array Top 1,400W

##### 3.1.1 Mechanics

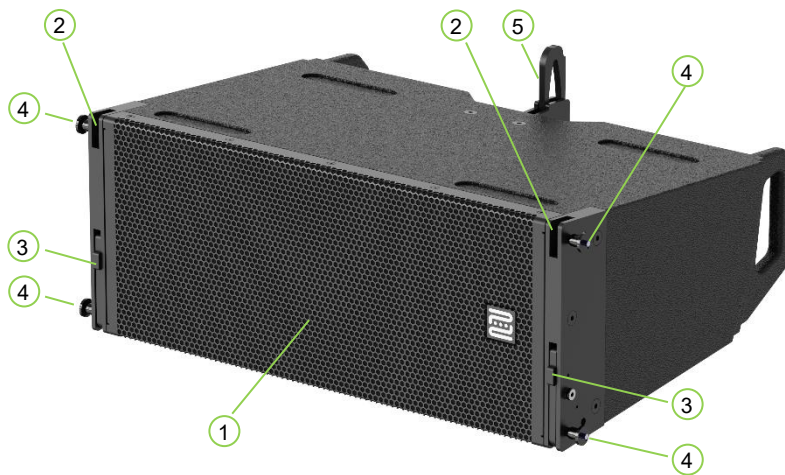

**No. Description of the**

- 1 XANA L-208 TA top
- 2 Connection opening for attaching the speaker to the front connecting slide of the flying frame or the top section above it
- 3 Front connecting slide for attaching an additional L-208 TA top unit
- 4 Socket pin with locking mechanism
- 5 Load bracket for connecting the speaker to the flying frame or for connecting to the top above it

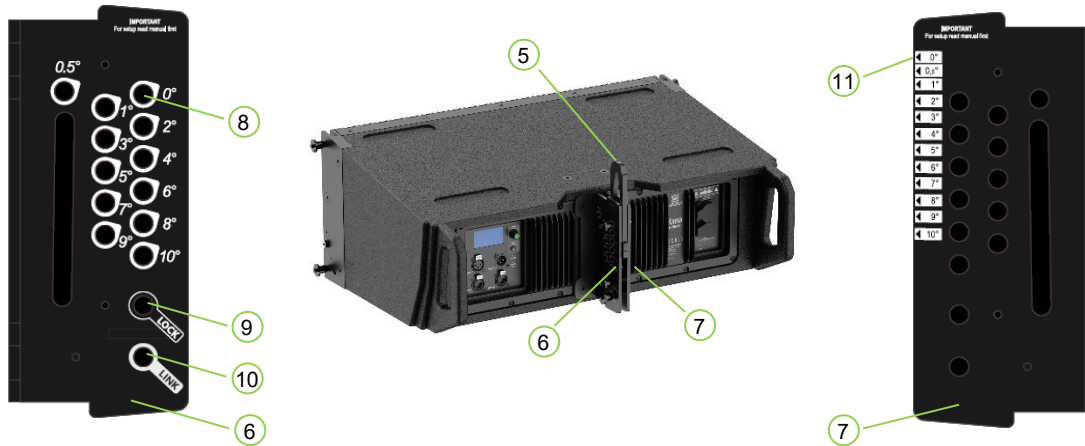

**No. Description of the**

- 5 Load bracket for connecting the speaker to the flying frame or for connecting to the top above it
- 6 Mounting rail (left side) incl. load bracket
- 7 Mounting rail (right-hand side) incl. load bracket
- 8 12 plug-in positions for the connecting pin to set the desired angle between 0.5° and 10°. This is used to fix the load bracket (5).
- 9 Plug-in position (LOCK) for fixing the position of the load bar of an L-208 TA top unit
- 10 Plug-in position (LINK) for mounting the load bracket of an L-208 TA top underneath
- 11 Imprint for checking the angle setting of 0.5°-10°. The angle is set with the arrow pointing to the marking (groove) in the load bracket (see Fig. 2)
- 12 Marking (groove) in the load bar

**Example:**

Image 1: Socket pin was set at 10°

Image 2: Groove in the load bracket points to 10° marking

Picture 1

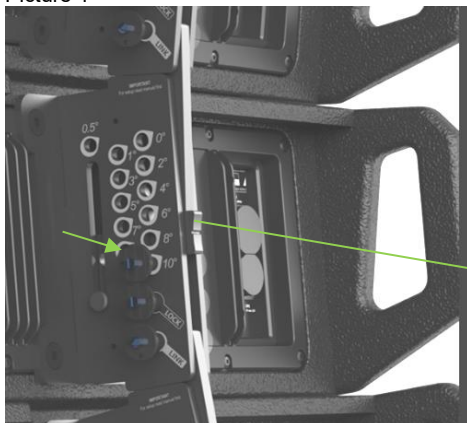

Picture 2



12

## 3.1.2 Electronics

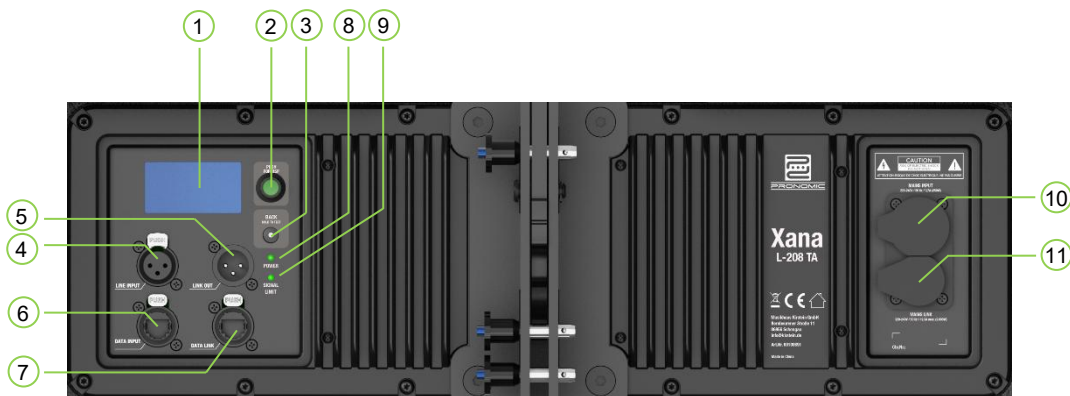

### No. Description of the

- 1 **LCD screen:** Provides access to speaker operating modes, DSP parameters, network settings and more
- 2 **PUSH FOR DSP:** Rotary control for parameter setting with push function to confirm the choice.
- 3 **BACK & HOLD TO TEST:** Button is used in conjunction with the rotary control to control the parameters displayed on the LCD screen.  
Short press = "back"  
Long press = (>5 sec.) starts a frequency sweep signal for speaker test
- 4 **LINE INPUT:** XLR input (balanced)  
The input signal is fed directly to the DSP.
- 5 **LINE OUT:** XLR output (balanced)  
The output receives the direct signal from the input and bypasses the DSP so that there is no latency. The output continues to function even in the event of a power failure.
- 6 **DATA INPUT:** etherCON network socket for controlling the parameters via RS485 protocol.
- 7 **DATA LINK:** etherCON network socket for connecting an additional device.
- 8 **POWER:** LED indicates whether the device is supplied with power.
- 9 **SIGNAL / LIMIT:** LED indicates whether signal is present or the amplifier is being overdriven
- 10 **MAINS INPUT:** Power connection input (powerCon True1 compatible)
- 11 **MAINS LINK:** Power connection output (powerCon True1 compatible) is used to supply power to other devices. ATTENTION: Do not exceed the max. power specifications.

### 3.2 XANA L-118 SA line array subwoofer 2,400W

#### 3.2.1 Mechanics

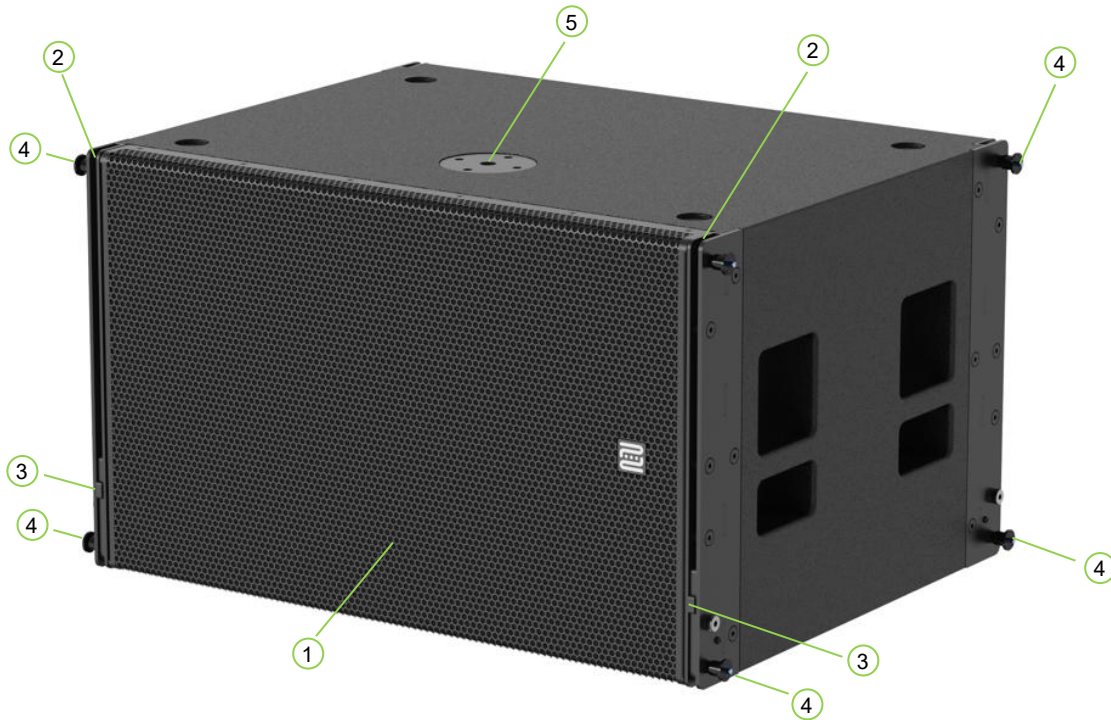

No.	Description of the
1	XANA L-118 SA subwoofer
2	Connection opening for attaching the speaker to the connecting slide of the flying frame or the subwoofer above it
3	Connecting slide for mounting an L-118 SA subwoofer underneath
4	Socket pin with locking mechanism
5	M20 threaded sleeve

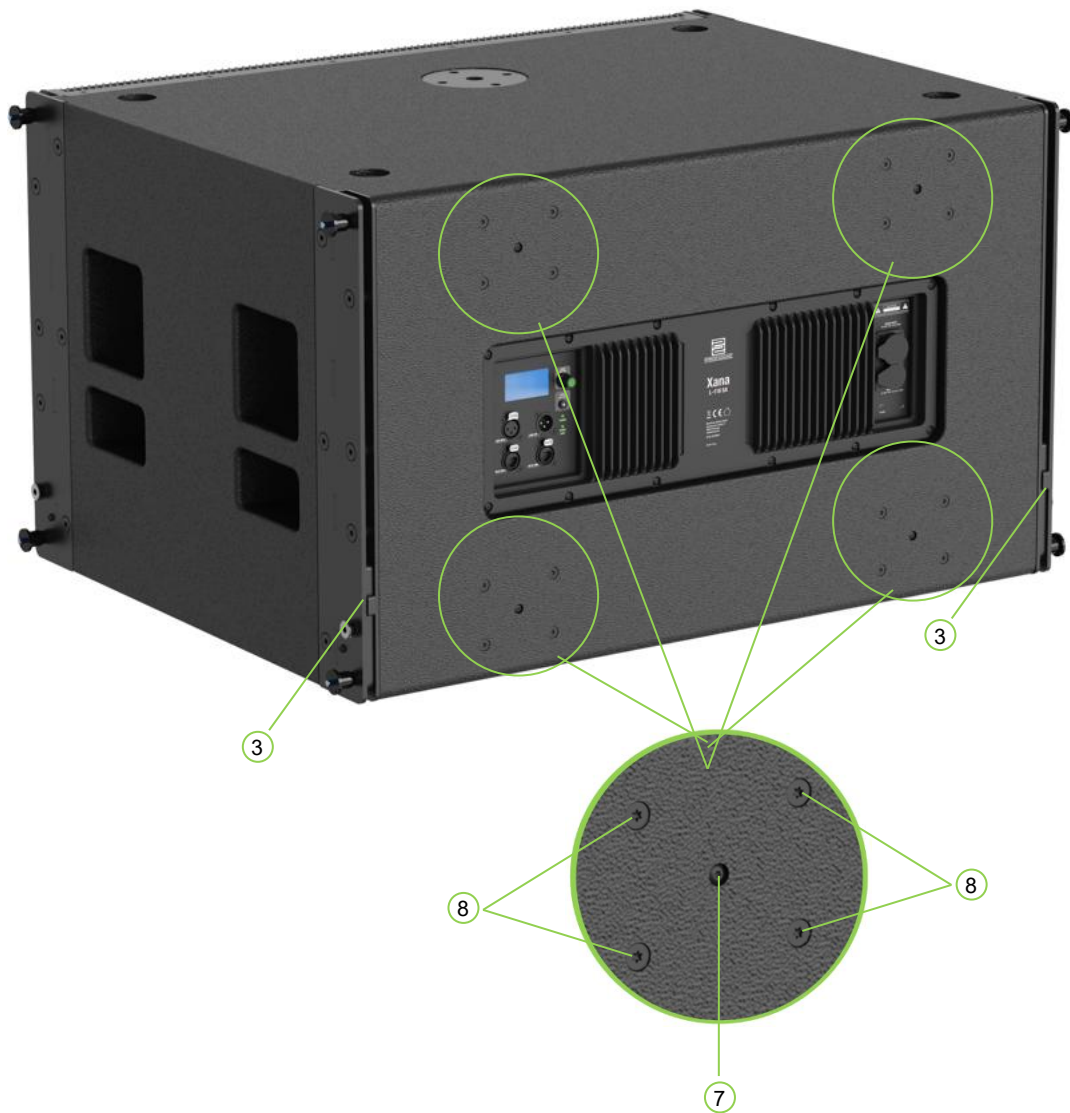

**No. Description of the**

- 7 Drive-in nut for fastening the rubber feet
- 8 M8 drive-in nuts for fastening transport rollers (hole size 80 mm x 60 mm)

## 3.2.2 Electronics

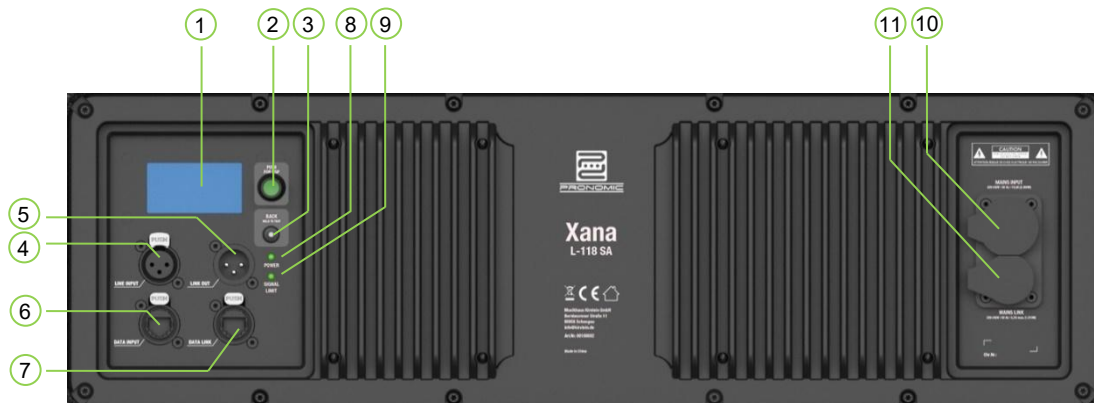

### No. Description of the

- 1 **LCD screen:** Provides access to speaker operating modes, DSP parameters, network settings and more
- 2 **PUSH FOR DSP:** Rotary control for parameter setting with push function to confirm the choice.
- 3 **BACK & HOLD TO TEST:** Button is used in conjunction with the rotary control to control the parameters displayed on the LCD screen.  
Short press = "back"  
Long press = (>5 sec.) starts a frequency sweep signal for speaker test
- 4 **LINE INPUT:** XLR input (balanced)  
The input signal is fed directly to the DSP.
- 5 **LINE OUT:** XLR output (balanced)  
The output receives the direct signal from the input and bypasses the DSP so that there is no latency. The output continues to function even in the event of a power failure.
- 6 **DATA INPUT:** etherCON network socket for controlling the parameters via RS485 protocol.
- 7 **DATA LINK:** etherCON network socket for connecting an additional device.
- 8 **POWER:** LED indicates whether the device is supplied with power.
- 9 **SIGNAL / LIMIT:** LED indicates whether a signal is present or whether the amplifier is being overdriven.
- 10 **MAINS INPUT:** Power connection input (powerCon True1 compatible)
- 11 **MAINS LINK:** Power connection output (powerCon True1 compatible) is used to supply power to other devices. ATTENTION: Do not exceed the max. power specifications.

## 3.3 Accessories

### 3.3.1 XANA L-208 TA Flying frame incl. flybar

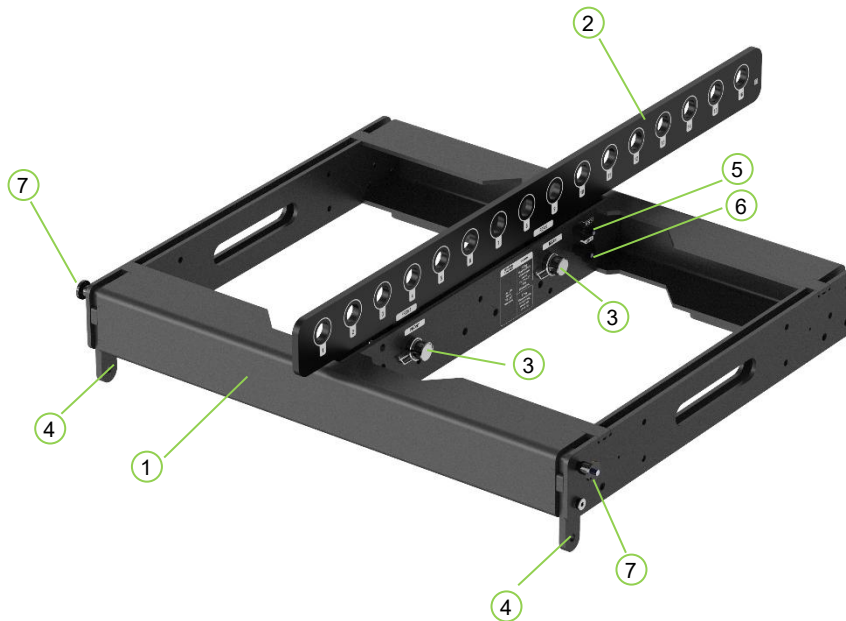

#### No. Description of the

- 1 The flying frame is designed to accommodate up to 16 flown XANA L-208 TAs
- 2 The flybar provides 16 possible hanging points (pick points). The diameter is 20 mm.
- 3 Connecting bolt between flying frame and flybar with safety pin
- 4 Front connecting slide for mounting an L-208 TA top unit
- 5 Rear connection point (LINK) for mounting the load bar of an L-208 TA top section
- 6 Rear connection point (LOCK) for fixing the position of the load bar of an L-208 TA top section
- 7 Socket pin with locking mechanism

The flybar can be used in both '**normal**' and '**inverse**' modes.

The '**normal**' mode is shown in the illustration. In this case, the '**FRONT**' marking on the flybar must be aligned with the '**FRONT**' marking on the airframe.

For "inverted" use, the flybar must be rotated by 180°. In this case, the "**FRONT**" marking on the flybar must be aligned with the "**REAR**" marking on the flying frame.

## 3.3.2 XANA L-118 SA flying frame incl. flybar

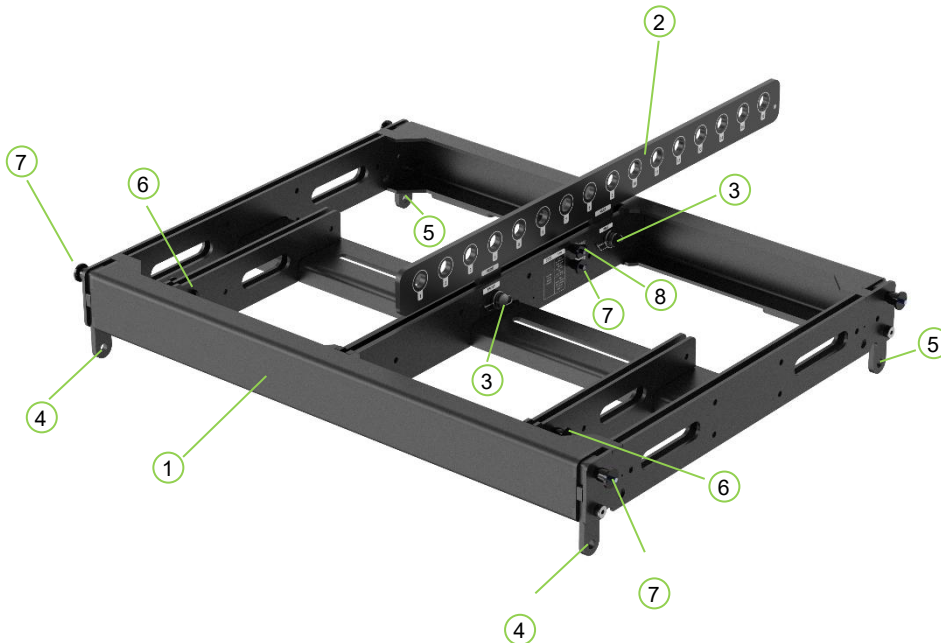

### No. Description of the

- 1 The flying frame is designed to accommodate up to 8 flown XANA L-118 subwoofers or 16 flown XANA L-208 subwoofers. Permitted combinations are also possible.
- 2 The flybar provides 16 possible hanging points (pick points). The diameter is 20 mm.
- 3 Connecting bolt between flying frame and flybar with safety pin
- 4 Front connecting slide for mounting an L-118 SA subwoofer
- 5 Rear connecting slide for mounting an L-118 SA subwoofer
- 6 Front connection point for mounting an L-208 TA top unit
- 7 Rear connection point (LINK) for mounting the load bar of an L-208 TA top section
- 8 Rear connection point (LOCK) for fixing the position of the load bar of an L-208 TA top section

The flybar can be used in both 'normal' and 'inverse' modes.

The 'normal' mode is shown in the illustration. In this case, the 'FRONT' marking on the flybar must be aligned with the 'FRONT' marking on the airframe.

For "inverted" use, the flybar must be rotated by 180°. In this case, the "FRONT" marking on the flybar must be aligned with the "REAR" marking on the flying frame.

## 3.3.3 XANA L-208 TA Transport Dolly

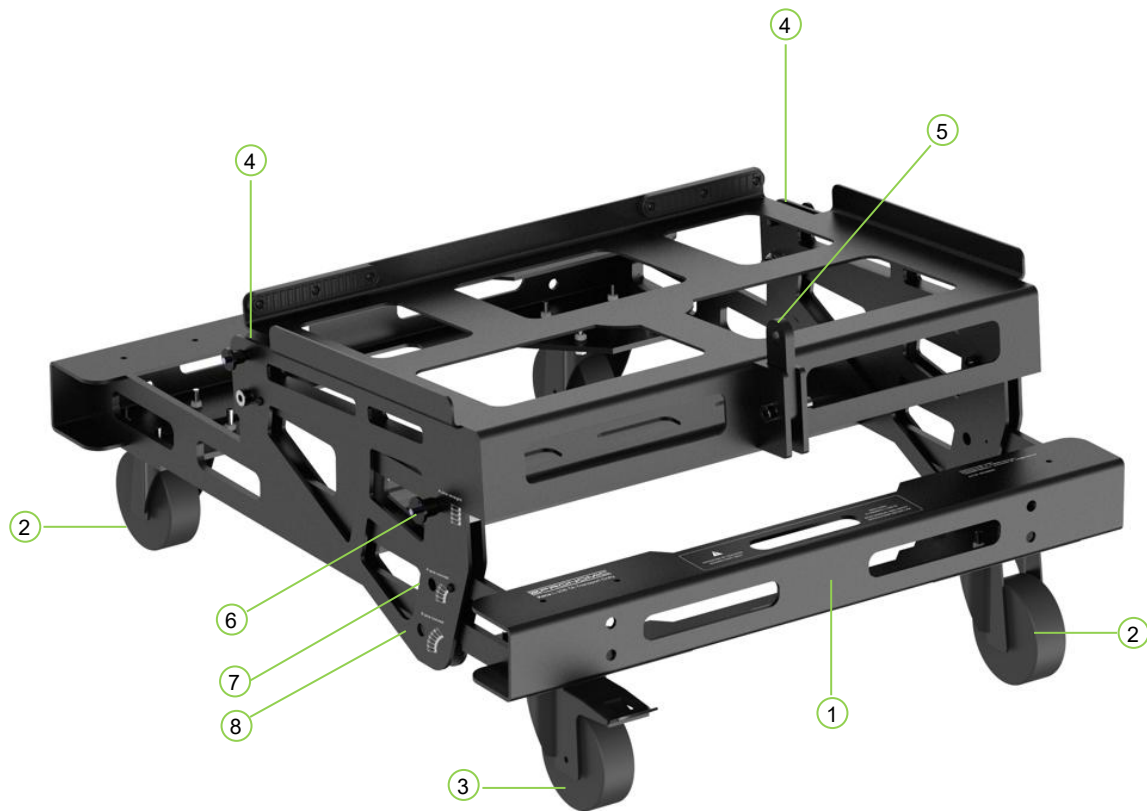

**No. Description of the**

- 1 The transport dolly is designed for convenient transport of up to 6 L-208 TA speakers
- 2 2 unbraked transport castors
- 3 2 braked transport castors
- 4 Connection opening for attaching the front connecting slide of the surface-mounted top section L-208 TA
- 5 Rear connection point for fixing the L-208 TA top in place via the LINK pin (similar to the load bracket of an L-208 TA top, only shortened)
- 6 "Straight" angle adjustment for upright mounting of up to 4 L-208 TA tops
- 7 Angle adjustment "4pcs curved" for angled mounting of up to 4 tops L-208TA
- 8 Angle adjustment "6pcs curved" for angled mounting of up to 6 tops L-208TA

## 3.3.4 XANA L-118 SA Transport Dolly

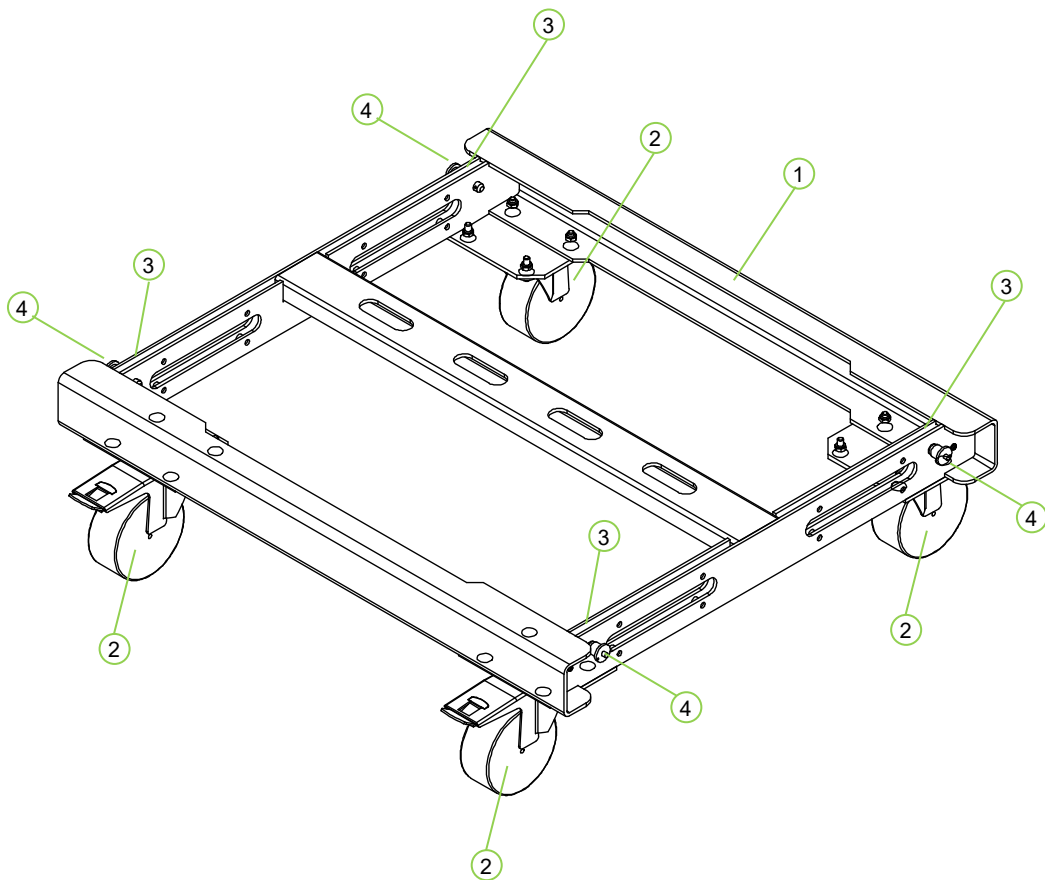

**Nr. Beschreibung**

- 1 The transport dolly is designed for convenient transport of up to 3 L-118 SA speakers
- 2 4 braked transport castors (125mm / 400kg load capacity)
- 3 Connection opening for attaching the speaker to the connecting slide of the flying frame or the subwoofer above it
- 4 Socket pin with locking mechanism

### 3.3.5 Other accessories

#### XANA Standbase für L-208TA Flugrahmen

For mounting the XANA L-208TA flying frame on the L-118SA subwoofer for use as a ground stack

Item no. 0011195

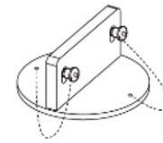

#### XANA Tilt Unit für L-208TA und L-118SA Flugrahmen

For connecting the XANA L-208TA speaker to the L-208TA and L-118SA flying frame. Angle settings from 0° to 10° possible.

Item no. 0011194

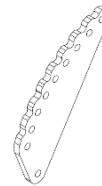

#### XANA L-208TA Schutzhülle für 4 Stück

Protective or transport cover for 4x XANA L-208TA speakers angled at 10° on the transport dolly.

Item no. 00108694



#### XANA L-208TA Schutzhülle für 6 Stück

Protective or transport cover for 6x XANA L-208TA speakers angled at 10° on the transport dolly.

Item no. 00108695



#### XANA L-118SA Schutzhülle

Protective and transport cover for XANA L-118SA subwoofer

Item no. 00108699

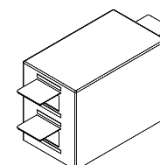

**XANA L-118SA Schutzhülle für 3 Stück**

Protective and transport cover for  
3x XANA L-118SA subwoofer on the dolly

Item no. 00108990

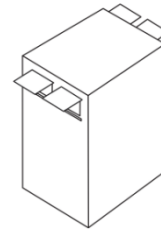

**XANA L-208 TA Regenschutz für Elektronik**

Metal frame with foldable fabric to protect  
the electronics

Item no. 00111201



**XANA L-118 SA Regenschutz für Elektronik**

Metal frame with foldable fabric to protect  
the electronics

Item no. 00111203



**Lenkrollen Satz 2x m.Bremse, 2x o.Bremse**

Castor set suitable for XANA L-118SA subwoofer  
hole size 80mm x 60mm / castor diameter 100mm

Item no. 00111805



**Pronomic USB-RS485 Interface für P.sysManager**

USB interface with etherCon compatible network socket  
for controlling the XANA L-208TA and L-118SA speakers

Item no. 00108696



## 4 DSP settings

The LCD screen on the back provides a user-friendly interface for setting various devices, speaker and network parameters.

Navigation through the menus is via the **"PUSH FOR DSP" endless controller**:

- **Turn** the control to scroll through menus and options.
- **Press** the slider to start editing a selected parameter.
- **Turn** again to set the desired value and
- **Press** again to confirm the selected value.

Press the **"BACK" button** to return to the previous menu. If you are in a confirmation dialogue, you can cancel the process with the BACK button.

All settings on the appliance are retained even after a power failure.

### 4.1 XANA L-208 TA

#### 4.1.1 Start screen

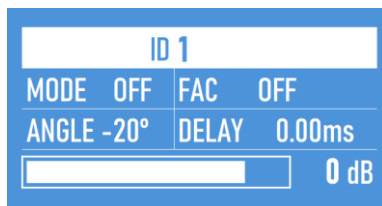

The start screen is displayed as soon as the device has completed the switch-on routine. Press the BACK button to return to the start screen from a submenu.

You can adjust the input sensitivity by turning the **Push For DSP** control.

Adjustable parameters: -80db to +12db

#### 4.1.2 Main menu

<b>HPF</b>	70Hz
ALC	OFF
FAC	OFF
MUTE	OFF
DELAY	0.00ms
TEST VOL	0dB
RESET	
INFO	0.05
ID	1
AOD	OFF

Pressing the **Push For DSP** control opens the main menu. You can access all submenus via the main menu.

The current menu position is highlighted in white. The white bar on the right-hand side indicates which area of the main menu you are in.

**4.1.3 Submenu**

HPF	70Hz
ALC	OFF
FAC	OFF
MUTE	OFF

**HPF** stands for High Pass Filter

Adjustable parameters: 70Hz - 120Hz

HPF	70Hz
ALC	4-6a
FAC	OFF
MUTE	OFF

**ALC** - Array Length Correction

Compensate the mid-range frequencies boost as the number of tops used increases

Adjustable parameters:

- 4 - 6a when using 4-6 tops
- 4 - 6b when using 4-6 tops
- 7 - 9a when using 7-9 tops
- 7 - 9b when using 7-9 tops
- 10 - 12 a when using 10-12 tops
- 10 - 12 b when using 10-12 tops
- 13+ a when using 13 or more L-208 TA
- 13+ b when using 13 or more L-208 TA
- 13+ c when using 13 or more L-208 TA

HPF	70Hz
ALC	OFF
FAC	1
MUTE	OFF

**FAC** - Field Ambience Correction

Compensate the high-range frequencies attenuation caused by increasing humidity and temperature

Adjustable parameters: 1 - 15

HPF	70Hz
ALC	OFF
FAC	OFF
MUTE	ON

**MUTE**

Mutes the input signal

Adjustable parameters: OFF / ON

DELAY	0.00ms
TEST VOL	0dB
RESET	
INFO	0.0.5

**DELAY**

Adjustable delay for runtime correction

Adjustable parameters: 0.00ms - 170.00ms

DELAY	0.00ms
TEST VOL	◀ 0dB
RESET	
INFO	0.0.5

**TEST VOL**

Adjustable volume of the loudspeaker test signals. The test signal is activated by pressing the BACK button for 5 seconds.

Adjustable parameters: 0dB to -18dB



**WARNING**

The test signal can be very loud and cause hearing damage

DELAY	0.00ms
TEST VOL	0dB
RESET	
INFO	0.0.5

**RESET**

Resets all parameters to factory settings.

Adjustable parameters: NO / YES

Security enquiry

**ARE YOU SURE?**

Return the device to its factory default condition

NO: back to the submenu  
 YES: Factory settings are loaded

DELAY	0.00ms
TEST VOL	0dB
RESET	
INFO	◀ 0.0.5

**INFO**

Firmware version of the device. Can be updated with the P.sys.MANAGER software.

RESET	
INFO	0.0.5
ID	▶ 1
AOD	OFF

**ID**

The identification number is used to assign the loudspeaker in the system. It must be set manually on the loudspeaker.

Adjustable parameters: 1 - 64

RESET	
INFO	0.05
ID	1
AOD	◀ 5Min ▶

## AOD

Auto Off Display switches the display off after the preset time

Adjustable parameters: OFF / 5 min. - 30 MIN.

## 4.2 XANA L-118 SA

### 4.2.1 Start screen

ID 2			
DELAY	0.00ms	ANGLE	0°
	NORMAL	HPF	30Hz
			0 dB

The start screen is displayed as soon as the device has completed the switch-on routine. Press the BACK button to return to the start screen from a submenu.

You can adjust the input sensitivity by turning the **Push For DSP** control.

Adjustable parameters: -80db to +12db

### 4.2.2 Main menu

LPF	40Hz
MODE	NORMAL
HPF	30Hz
MUTE	OFF
DELAY	0.00ms
POLARITY	0°
TEST VOL	0dB
RESET	
INFO	1.0.0
ID	2
AOD	OFF

Pressing the **Push For DSP** control opens the main menu. You can access all submenus via the main menu.

The current menu position is highlighted in white. The white bar on the right-hand side indicates which area of the main menu you are in.

### 4.2.3 Submenu

LPF	40Hz ▶
MODE	NORMAL
HPF	30Hz
MUTE	OFF

**LPF** stands for Low Pass Filter

Adjustable parameters: 40Hz - 120Hz

LPF	40Hz
MODE	NORMAL
HPF	30Hz
MUTE	OFF

**MODE**

is used to set the cardioid function.

Adjustable modes: NORMAL  
CARDIOID FRONT  
CARDIOID REAR

LPF	40Hz
MODE	NORMAL
HPF	30Hz
MUTE	OFF

**HPF** stands for High Pass Filter

Adjustable parameters: 30Hz - 120Hz

LPF	40Hz
MODE	NORMAL
HPF	30Hz
MUTE	ON

**MUTE**

Mutes the input signal

Adjustable parameters: OFF / ON

DELAY	0.00ms
POLARITY	0°
TEST VOL	0dB
RESET	

**DELAY**

Adjustable delay of the playback signal

Adjustable parameters: 0.00ms - 170.00ms

DELAY	0.00ms
POLARITY	0°
TEST VOL	0dB
RESET	

**POLARITY**

Adjustable phase position

Adjustable parameters: 0° and 180°

DELAY	0.00ms
POLARITY	0°
TEST VOL	0dB
RESET	

**TEST VOL**

Adjustable volume of the loudspeaker test signals. The test signal is activated by pressing the BACK button for 5 seconds.

Adjustable parameters: 0dB to -18dB



**WARNING**

The test signal can be very loud and cause hearing damage

DELAY	0.00ms
POLARITY	0°
TEST VOL	0dB
<b>RESET</b>	

**RESET**

Resets all parameters to factory settings.

Adjustable parameters: NO / YES

Security enquiry

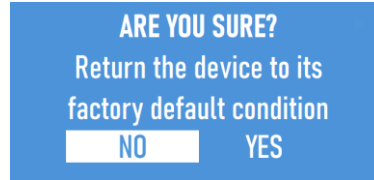

NO: back to the submenu

YES: Factory settings are loaded

<b>RESET</b>	
INFO	1.0.0
ID	2
AOD	OFF

**INFO**

Firmware version of the device. Can be updated with the P.sys.MANAGER software.

<b>RESET</b>	
INFO	1.0.0
ID	2
AOD	OFF

**ID**

The identification number is used to assign the loudspeaker in the system. It must be set manually on the loudspeaker.

Adjustable range: 1 - 64

<b>RESET</b>	
INFO	1.0.0
ID	2
AOD	5Min

**AOD**

Auto Off Display switches the display off after the preset time

Adjustable range: OFF / 5 min. - 30 MIN.

## 5 P.sysMANAGER - Software



The P.sysMANAGER software was specially designed to control the XANA line array systems and runs under Microsoft Windows® 10 or later .

The "Pronomic USB-RS485 Interface for P.sysManager" Art.No.00108696 is required for the connection between the computer and the loudspeakers.

The software gives you access to all the parameters of each individual speaker connected to the interface. Additional functions such as EQ, grouping etc. are also available.

For convenient system planning, the software also works offline (without connected devices) so that configurations can be saved as projects before installation.

You can download the software under the link: <https://www.kirstein.de/Xana>

## 6 EASE Focus 3 - Software

The EASE Focus 3 software is available for acoustic and mechanical simulation of the XANA line array system.

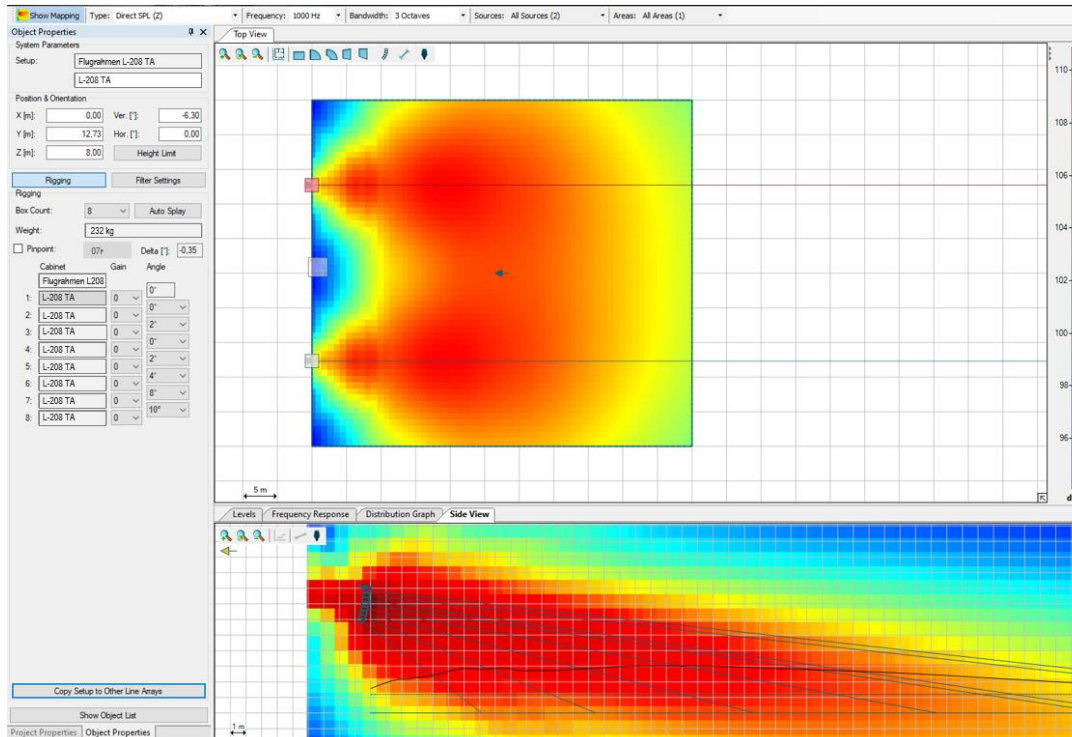

### Using EASE Focus 3

You can download the software free of charge from <https://www.afmg.eu/en/ease-focus>. The software can be used to easily determine how the XANA line array speakers need to be tilted and angled in order to achieve optimum sound distribution in the audience area. Please observe all warnings displayed during use and always check the plausibility of the simulation results.

You can download the XANA simulation data for use in EASE Focus via the following link: <https://www.kirstein.de/Xana>



If the software issues a warning, the system is mechanically overloaded. The system must not be flown in this configuration under any circumstances. In such a case, adjust the configuration so that the warning disappears.

## Optimum alignment of the line array system

Use the "Auto-Splay function" of the software to determine the required angle settings. The lowest unit of the array should be just above the head height of the people standing on the stage. This allows the entire system to be operated with only slight angles between the individual elements - a decisive advantage for acoustic coupling (cylindrical wave principle).



### Important notes on security and system configuration

Also pay attention to the permissible loads listed in the following **section 7 "Load limits"**. Even minor deviations in the overall inclination or angle configuration can significantly affect both, the physical load limits and the acoustic result.

## 7 Load limits

The products and accessories in the XANA Line Array series have been designed in accordance with the guidelines of DGUV regulation 17 (BGV-C1) with a minimum breakage safety factor of 1:3.75.

Up to 16 L-208TA tops can be flown on the XANA L-208TA Flying Frame. The XANA L-118SA Flying Frame allows up to 8 L-118SA subwoofers or a combination of 2x L-118SA subwoofers and a maximum of 12x L-208TA tops to be flown.

However, the actual number of units permitted depends on the downtilt of the array and the pickpoint used. The downtilt itself depends on:

- the length of the array
- the position of the pickpoint and
- the angulation of the individual XANA elements.

As the Flying Frame is always connected to the uppermost top section or subwoofer at an angle of 0°, the inclination of the frame automatically corresponds to the inclination of the uppermost element. **Note:** For a 0° alignment of the uppermost top section L-208TA on the flying frame, the LINK pin must be set at 2°.

**Important note on planning**

Before installation, it is recommended to simulate the desired system configuration using the EASE Focus 3 software.

The maximum possible loads can be found in the table below. If the software nevertheless issues a warning, the system is mechanically overloaded. The system must not be flown in this configuration under any circumstances. In such a case, adjust the configuration so that the warning disappears.

**7.1 XANA L-208 TA flying frame incl. flybar**

Load specifications apply to the flybar in the **'normal'** and **'invers'** positions

Hanging point (pick point)	Max. permissible number Tops L-208 TA
1 - 12	16
13	15
14	14
15	12
16	10

## 7.2 XANA L-118 SA flying frame incl. flybar

### 7.2.1 Flybar in position “normal”

Hanging point (pick point)	Max. permissible number Tops L-208 TA	Max. permissible number Subwoofer L-118 SA	Max. permissible combination of 2x subwoofers L-118 SA + number of L-208 TA tops
1	9	3	+ 3
2	15	4	+ 4
3	16	5	+ 6
4	16	5	+ 8
5	16	8	+ 12
6	16	8	+ 12
7	16	8	+ 12
8	16	8	+ 12
9	16	8	+ 12
10	15	8	+ 12
11	14	8	+ 12
12	13	8	+ 12
13	12	6	+ 11
14	12	5	+ 7
15	10	4	+ 4
16	6	3	+ 3

**7.2.2 Flybar in position "invers"**

Hängepunkt (Pickpoint)	Max. zulässige Anzahl Topteile L-208 TA	Max. zulässige Anzahl Subwoofer L-118 SA	Max. zulässige Kombination aus 2x Subwoofer L-118 SA + Anzahl Topteile L-208 TA
1	10	3	+ 3
2	11	4	+ 4
3	12	6	+ 6
4	14	5	+ 8
5	15	8	+ 12
6	16	8	+ 12
7	16	8	+ 12
8	16	8	+ 12
9	16	8	+ 12
10	16	8	+ 12
11	16	8	+ 12
12	16	8	+ 12
13	15	6	+ 11
14	14	5	+ 7
15	11	4	+ 4
16	10	3	+ 3

## 8 Assembly

### 8.1 Connections

#### 8.1.1 Locking pin with locking mechanism

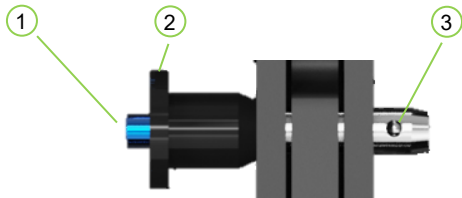

No.	Description of the
-----	--------------------

- |   |               |
|---|---------------|
| 1 | Spring button |
| 2 | Retaining rim |
| 3 | Locking       |

Press and hold the spring button during the insertion process. As soon as the bolt is fully inserted, release the spring button. Make sure that it then pops out again completely and the plug-in bolt is locked in place.



#### WARNING

Do not use force! If handled correctly, all connection points are easy to move!

Never plug or unplug connections under load.

Always ensure that all the connection points described have been established and securely connected.

### 8.1.2 Connecting bolt with safety split pin

There is a groove in the centre of the flying frame (1.) into which the flybar (2.) must be inserted. Make sure that the "FRONT" marking on the flybar points to the "FRONT" marking on the flying frame. Insert the flybar (2.) so deeply into the flying frame (1.) that the two connection openings (3.) are parallel to each other. Now insert the connecting bolt (4.) through the connecting opening (3.). Then secure the connecting bolt (4.) with the safety split pin (5.) to prevent it from falling out.

Proceed with the "REAR" connection in the same way as the "FRONT" connection

The flybar can also be used 'inversely'. In some situations, the flybar needs to be rotated by 180° (mounted inversely). In this case, the 'FRONT' marking on the flybar points towards the 'REAR' of the airframe.

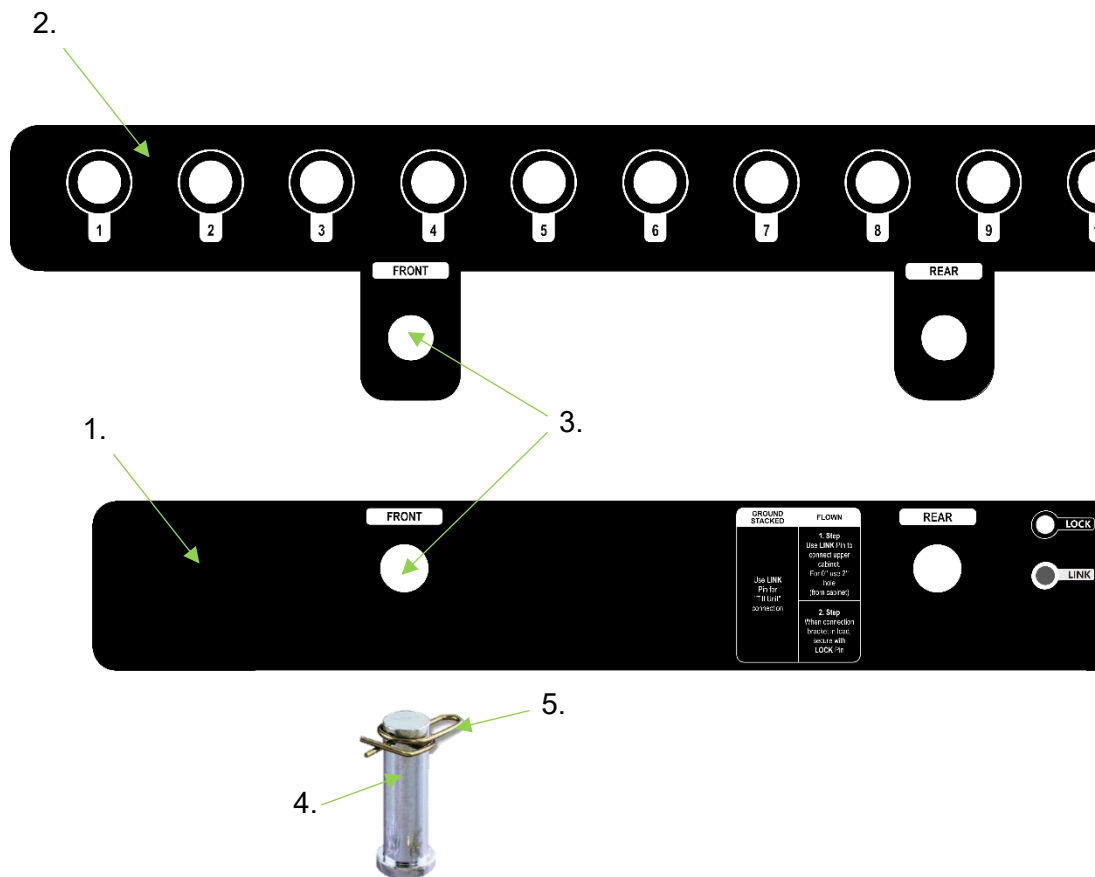

Check that the connecting bolts and safety cotter pins are correctly and securely seated before each use!

**8.2 Transport dolly**

**8.2.1 Adjusting the base plate**

First decide how many tops you want to transport on the dolly. You have the option of stacking either 4 or 6 elements.

There are two tilt positions for the base plate

To adjust the tilt, remove the two pins on the long side of the dolly. Tilt the base plate to the desired position using the illustrations and fix the plug pin in the corresponding hole.

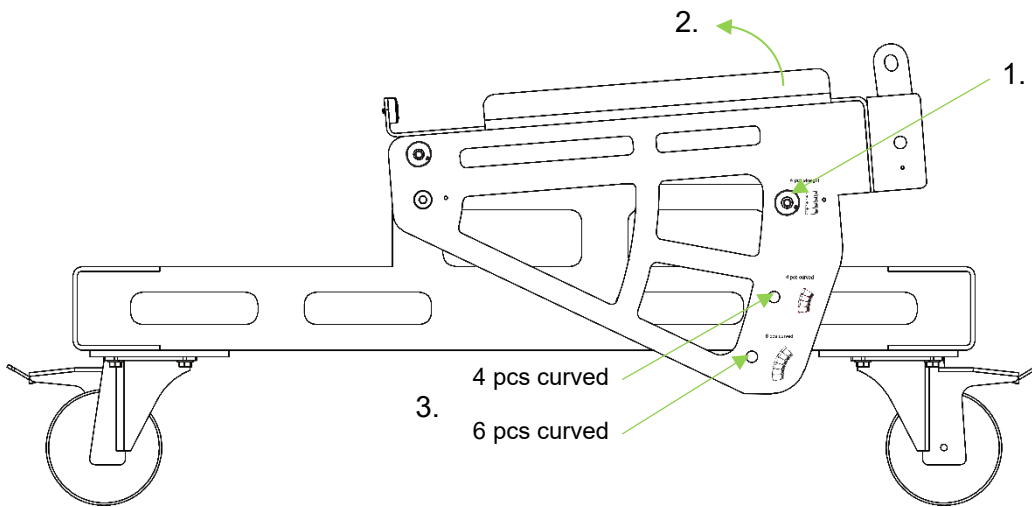

4 pcs curved

6 pcs curved

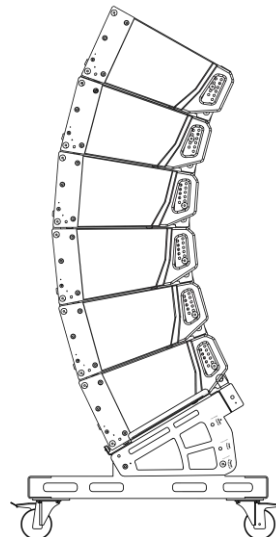
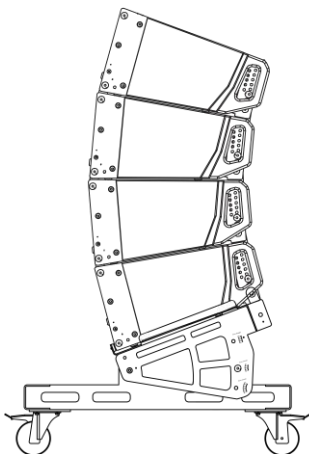

Info: There is a third position for stacking the tops with a fixed 0° angle. To do this, please follow the steps in the "Ground stack" section

### 8.2.2 Fixing the top section to the base plate

- Lift the first top section (1.) flush with the front grille onto the base plate and remove the two plug-in bolts (2.) at the front end of the base plate.
- Then remove the front plug-in bolts of the top section (3.), causing the connecting slide (4.) to slide downwards out of the housing. Secure the slide directly with these plug-in bolts (3.) in the same plug-in position.
- Then make the connection with the hole in the connecting slide by inserting the pins (2.) of the base plate back into position.
- Remove the LINK pin (5.) on the back of the top section. You can then fold the rear hinged bracket of the base plate (6.) upwards and secure it to the top section (5.) using the LINK pin.

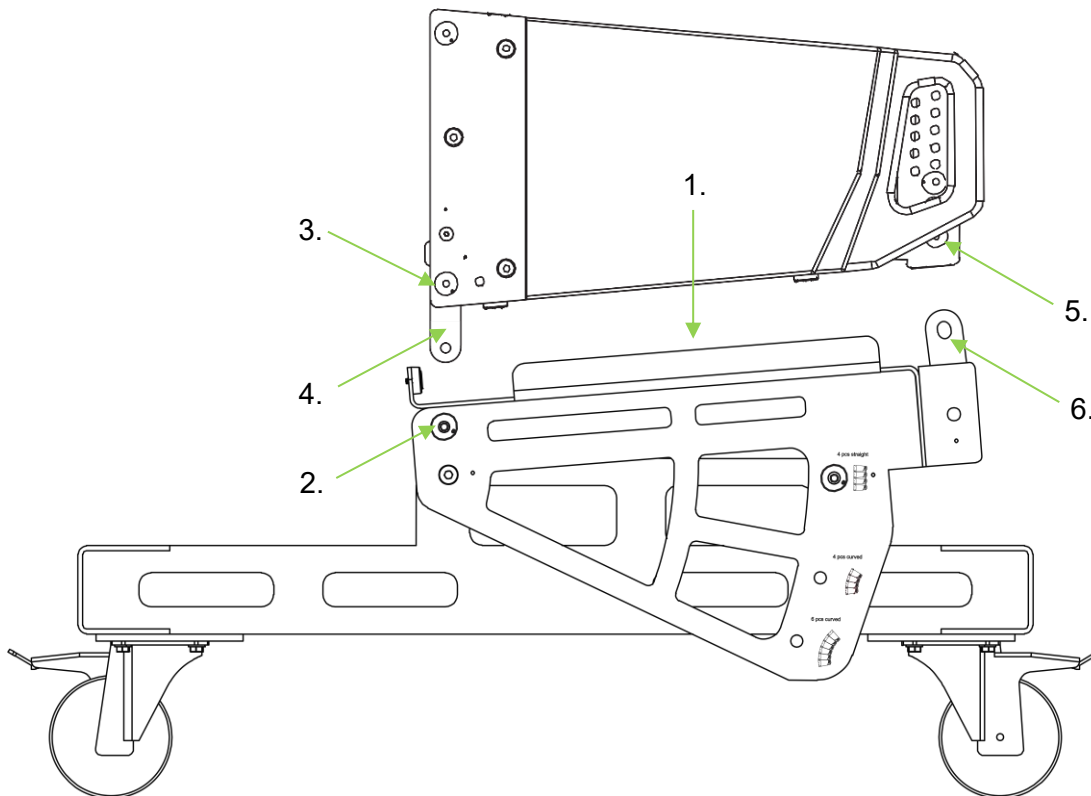

### 8.2.3 Fixing top section to top section

- Lift the next top section flush with the front grille onto the previous top section so that the rubber feet engage in the recesses (1.).
- Then remove the front plug-in bolts (3.) of the top section, allowing the connecting slide (4.) to slide downwards out of the housing. Secure the connecting slide directly with these plug-in bolts (3.) in the same plug-in position.
- Then make the connection with the hole in the connecting slide by inserting the rear pins (5.) of the top section into the holes on the top of the top section underneath (6.), where the ends of the connecting slides are also inserted.
- Remove the LINK pin (7.) on the back of the top section. Now push the load bar (8.) of the lower top section upwards until it touches the LOCK pin (9.) of the upper top section.
- The load bracket can be fixed in this position with the LINK pin (7.).
- Repeat this step according to the number of top sections set.

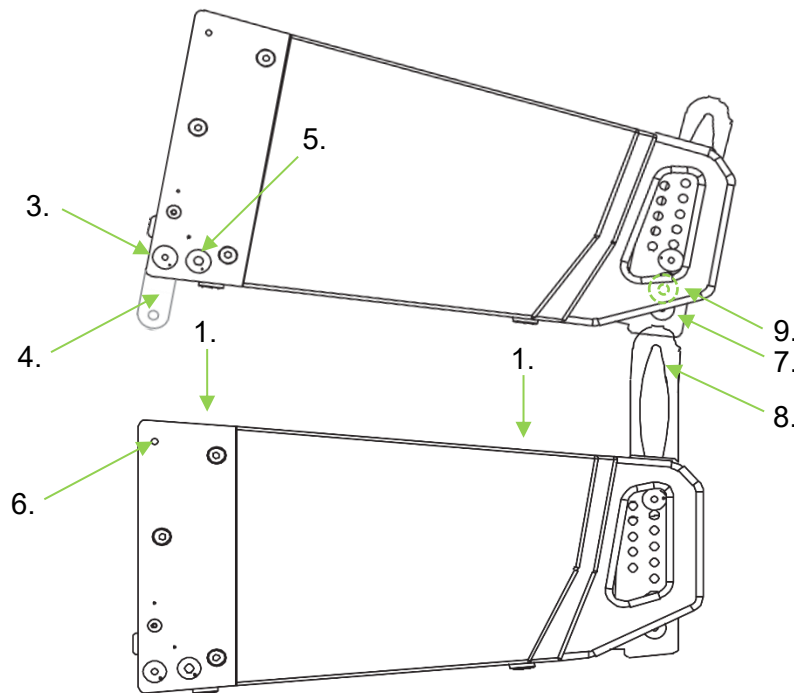

### 8.3 Ground stack

#### 8.3.1 Fixing subwoofer to subwoofer

- Lift the subwoofer flush with the front grille onto the lower subwoofer so that the rubber feet (1.) engage in the recesses. Two people are required for this.
- Remove the lower four plug-in bolts of the upper subwoofer (3.), the connecting slide (4.) will slide downwards out of the housing. Secure the connecting slide (4.) directly in the upper holes of the lower subwoofer (2.) using the same plug-in bolts (3.).
- Repeat this step for several subwoofers if necessary.

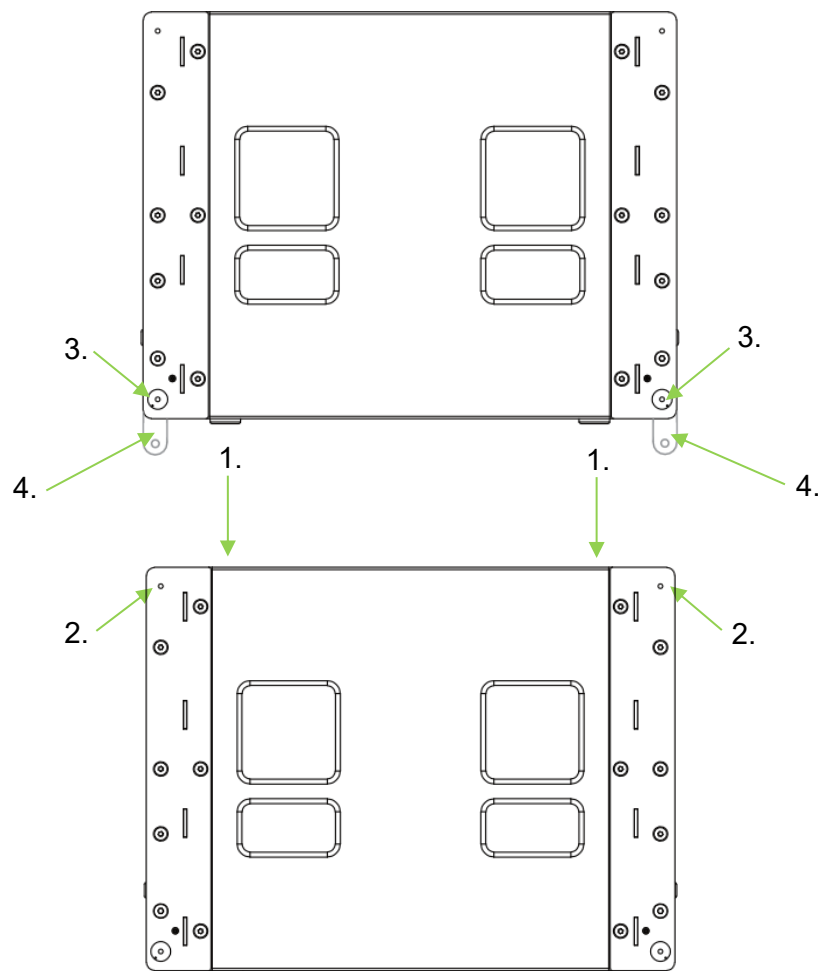

### 8.3.2 Flying frame on subwoofer

#### 8.3.2.1 Using the Xana L-118 SA flying frame

- Remove the four lower pins (1.) at the corners of the flying frame. The connecting slides (4.) with slotted hole fold out of the frame. Then push the socket pins (1.) back into their parking position.
- Remove the upper plug pin (2.) at each corner and slide the connecting slide along the slotted hole towards the position where the upper plug pin (2.) was and fix the slide there.
- Lift the flying frame flush with the outer edges onto the subwoofer. Use the labelling to ensure the correct orientation (top/bottom; front/rear). The instructions are located on the back of the frame.
- Then fix the flying frame to the subwoofer by inserting the parked lower four plug-in bolts (1.) of the flying frame into the upper four holes of the flying frame (5.) (through the connecting slide).

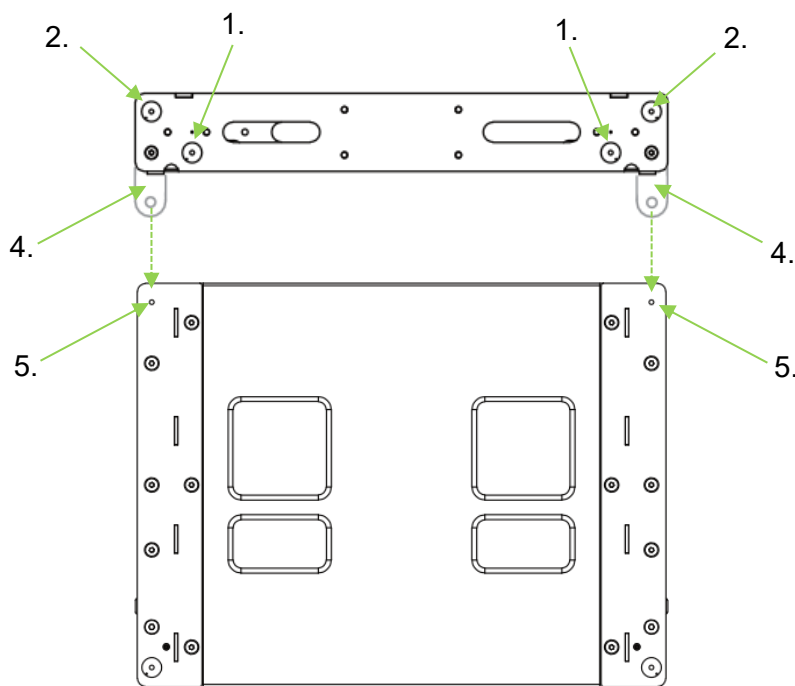

### 8.3.2.2 Using the Xana L-208 SA flying frame with standbase

- Screw the standbase (1.) (accessory item XANA standbase for L-208TA flying frame art. no. 0011195) into the M20 thread (2.) of the upper subwoofer and open the two plug-in bolts of the standbase (5.).
- Lift the flying frame (3.) onto the subwoofer, so that the steel plate of the standbase is in the centre of the flying frame in the gap between the two centre struts (4.). Use the labelling to ensure the correct alignment (top/bottom; front/rear). The connecting slides of the flying frame remain in the park position.
- Move the flying frame back and forth on the subwoofer until the hole pattern in the flying frame matches the hole pattern in the standbase. Now secure the flying frame to the standbase using the two plug-in bolts (5.).

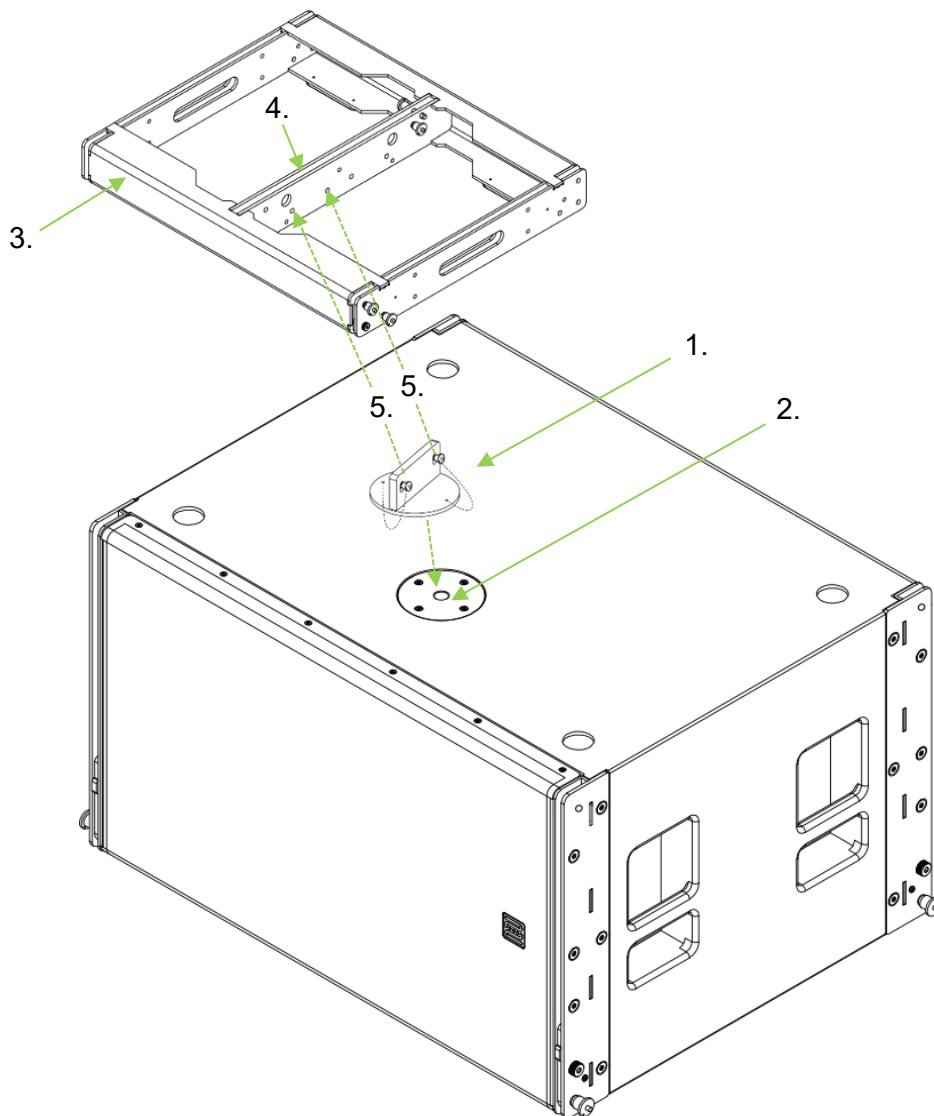

### 8.3.3 Fixing the top section to the flying frame

- Insert the tilt unit (1.) (accessory item no. 0011194) at the position of the LINK pin (2.) so that the toothed side is facing the front.
- Lift the first top flush with the front grille onto the flying frame.
- Remove the two front pins (3.) on the flying frame.
- Then remove the front plug-in bolts of the top section (4.), causing the connecting slide (5.) to slide downwards out of the housing. Then secure the connecting slide again directly with the plug-in bolts (4.) in the same plug-in position.
- Now connect the top section to the flying frame by pushing the front plug-in bolts (3.) of the flying frame back into position.
- Now remove the LINK pin (6.) on the back of the top section. Fold the tilt unit (1.) upwards and connect the tilt unit to the top section by inserting the LINK pin through the hole with the desired angle.

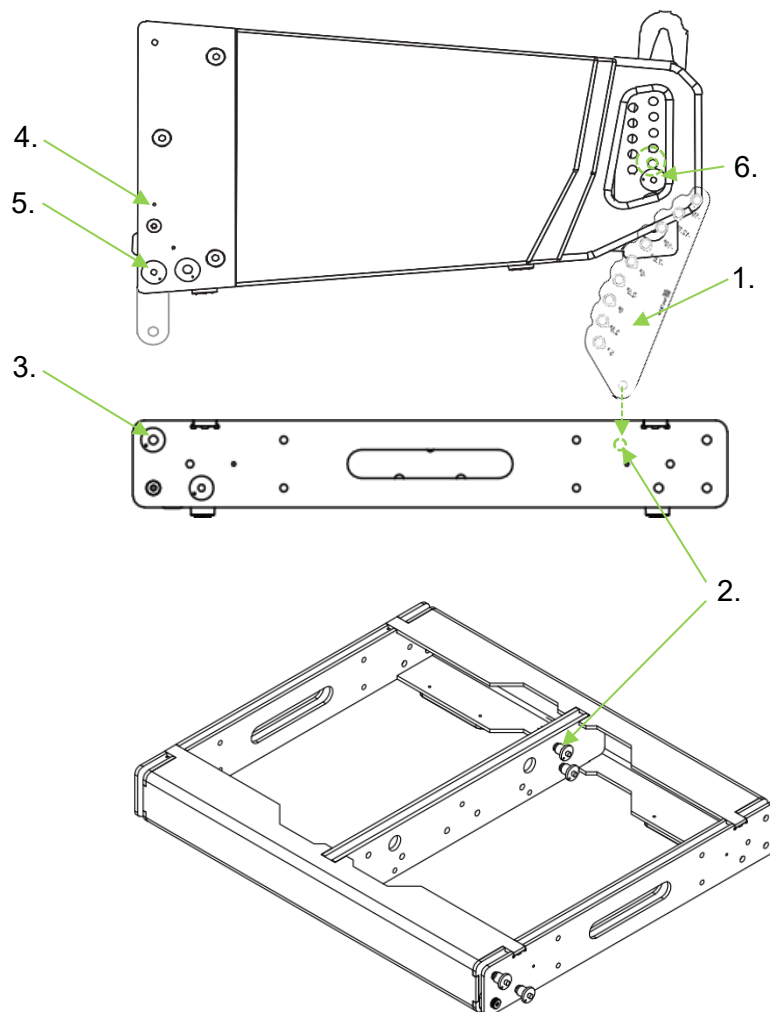

### 8.3.4 Fixing the top section to the top section

- Lift the next top section flush with the front grille onto the previous top section so that the rubber feet engage in the recesses (1.).
- Then remove the front plug-in bolts (3.) of the top section, allowing the connecting slide (4.) to slide downwards out of the housing. Secure the connecting slide directly with these plug-in bolts (3.) in the same plug-in position.
- Then make the connection with the hole in the connecting slide by inserting the rear plug pins (5.) of the top section into the holes on the top of the top section below (6.), where the ends of the connecting slides are also inserted.
- Remove the LINK pin (7.) on the back of the top section. Now push the load bar (8.) of the lower top section upwards, until it touches the LOCK pin (9.) of the upper top section.
- To set the desired angle, lift the top section sideways by the handles until the groove in the load bracket matches the desired angle on the scale on the right-hand side of the mounting rail.
- Then insert the connecting pin (10.) from the left-hand side of the mounting rail through the hole with the desired angle
- Repeat this step according to the number of top sections set.

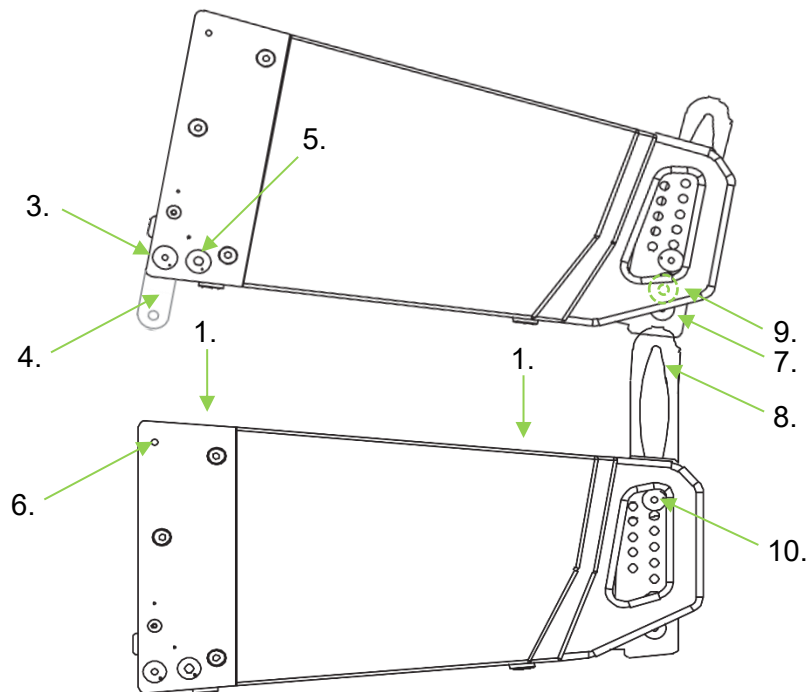

## 8.4 Flown system without subwoofer

### 8.4.1 Fixing the flying frame to top sections with transport dolly

- Remove the two lower pins (1.) on the left and right at the front corners of the flying frame. The connecting slides (2.) with slotted hole fold out of the frame. Then push the locking pins (1.) back into their park position.
- Remove the upper plug pin (3.) at the front corners. Slide the connecting slide along the slotted hole towards the position where the upper plug pin (3.) was and fix the slide there.
- Now lift the flying frame with these connecting slides flush to the front into the corresponding grooves of the top section (4.)
- Fix the connecting slides (2.) through the upper holes on the front of the top section (4.) with the lower plug-in bolts (1.) of the flying frame.
- Remove the rear LINK pin (5.) of the flying frame
- Now push the load bar (6.) of the uppermost top section upwards until it touches the LOCK pin (7.) of the flying frame.
- The load bracket (6.) can be fixed in this position with the LINK pin (5.).
- Now remove the LOCK pins (8.) from all top units on the transport dolly. The LINK pins (10.) always remain inserted.
- To set the desired angle, remove the angle pin (9.) from the top section underneath and slide the load bracket (6.) upwards, until the groove in the load bracket matches the desired angle on the scale on the right-hand side of the mounting rail
- Then insert the angle pin (9.) from the left-hand side of the mounting rail through the hole with the desired angle
- Repeat this step accordingly with the next top sections.

#### NOTE

To connect the uppermost top section to the flying frame, set ALWAYS set 2° to achieve a 0° angle. Follow the instructions on the flying frame!

- Now remove the three plug-in bolts (11.) that secure the top sections on the transport dolly.
- You can now lift the tops out of the dolly. This will automatically create the set angles.
- As soon as the array is under load, put all the LOCK pins (8.) back into position to lock the brackets in place.

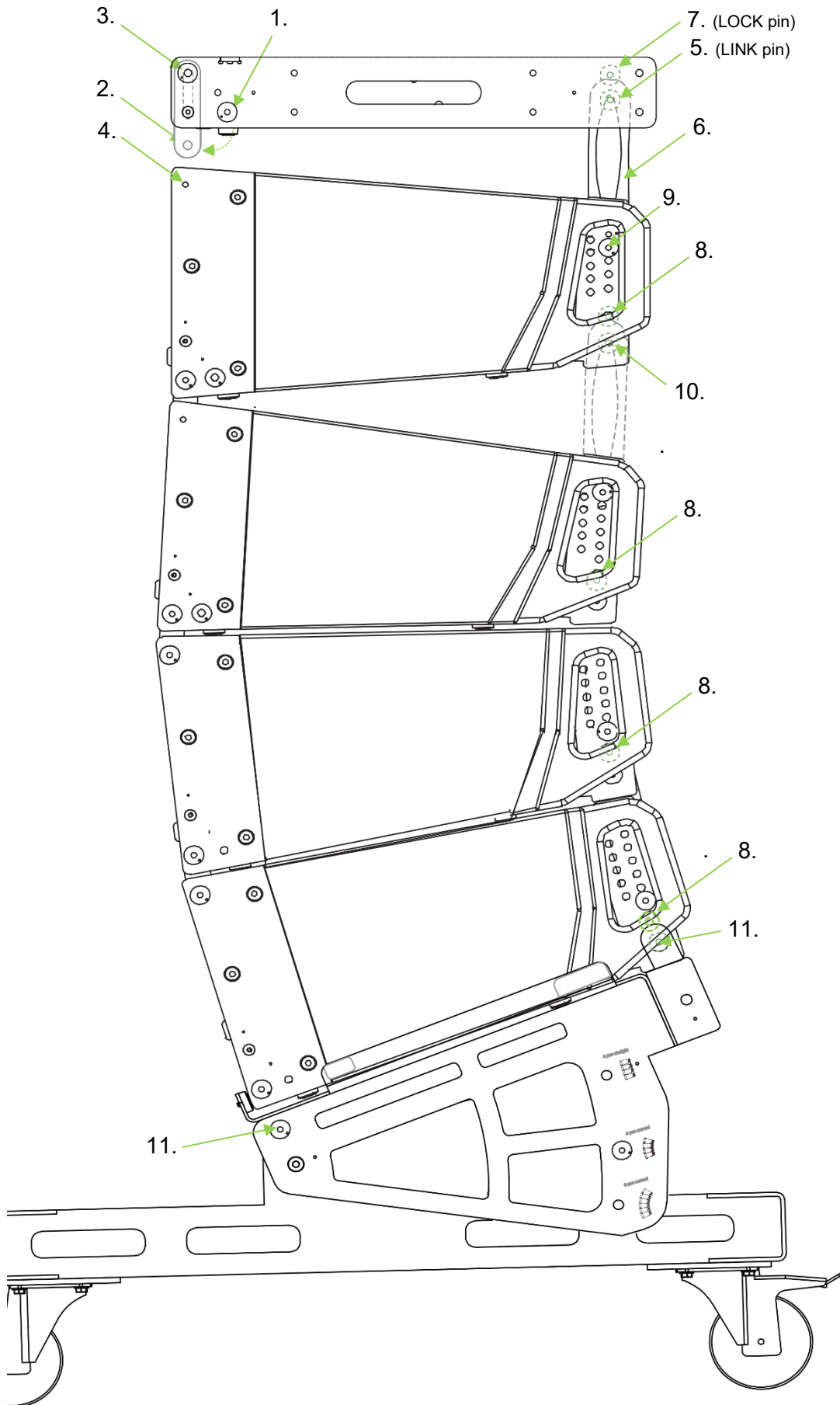

#### 8.4.2 Fixing flying top section on top section with transport dolly

- Remove the front plug-in bolts (1.) from the bottom top section of the array. The connecting slide (2.) will slide downwards out of the housing. Secure the slide directly with the plug-in bolts (1.) in the same plug-in position.
- Now lift the array with these connecting slides flush to the front into the corresponding grooves of the top section of the next transport dolly.
- Then make the connection with the hole in the connecting slide by inserting the rear pins (3.) of the lowest suspended top section into the holes (4.) on the top of the top section below, where the ends of the connecting slides (2.) are also inserted.
- Remove the LINK pin (5.) of the lowest suspended top section
- Now push the load bar (6.) of the topmost top section on the transport dolly upwards until it touches the LOCK pin (7.) of the lowest suspended top section.
- The load bracket (6.) can be fixed in this position with the link pin (5.).
- Now remove the LOCK pins (8.) from all tops on the transport dolly. The LINK pins always remain inserted.
- To set the desired angle, remove the angle pin (9.) from the top section underneath and slide the load bracket (10.) upwards, until the groove in the load bracket matches the desired angle on the scale on the right-hand side of the mounting rail (for details, see chapter 3.1.1)
- Then insert the angle pin (11.) from the left-hand side of the mounting rail through the hole with the desired angle
- Repeat this step accordingly with the next top sections.
- Now remove the three pins (12.) that secure the top sections on the transport dolly.
- You can now lift the tops out of the dolly. This will automatically create the set angles.
- As soon as the array is under load, put all LOCK pins (8.) back into position to lock the brackets.

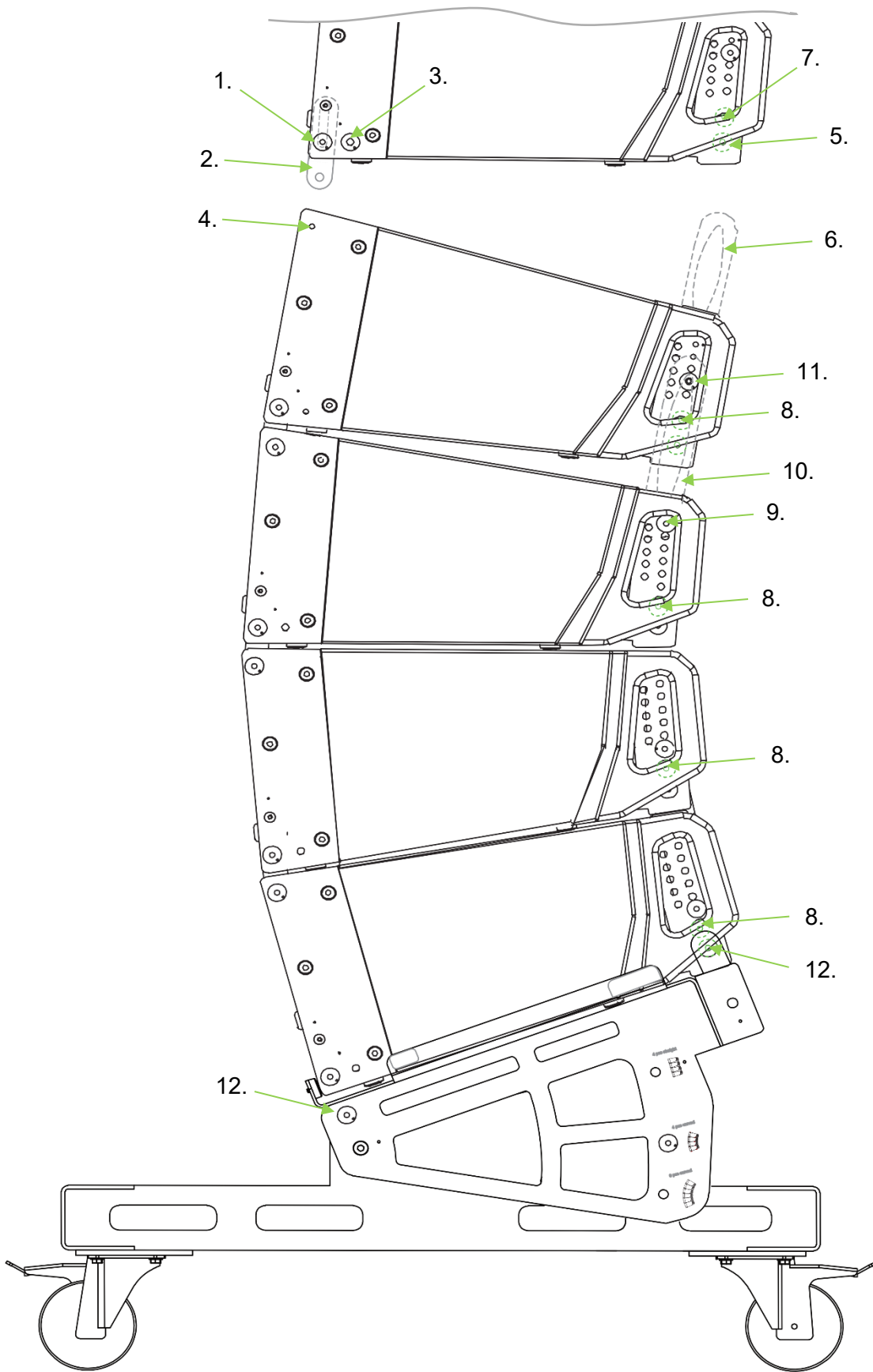

## 8.5 Flown system with subwoofer

### 8.5.1 Fixing the L-118 SA flying frame to the subwoofer

- Remove the four lower pins (1.) at the corners of the flying frame. The connecting slides (4.) with slotted hole fold out of the frame. Then push the socket pins (1.) back into their parking position.
- Remove the upper plug pin (2.) at each corner and slide the connecting slide along the slotted hole towards the position where the upper plug pin (2.) was and fix the slide there.
- Lift the flying frame flush with the outer edges onto the subwoofer. Use the labelling to ensure the correct orientation (top/bottom; front/rear). The instructions are located on the back of the frame.
- Then fix the flying frame to the subwoofer by inserting the parked lower four plug-in bolts (1.) of the flying frame into the upper four holes of the flying frame (5.) (through the connecting slide).

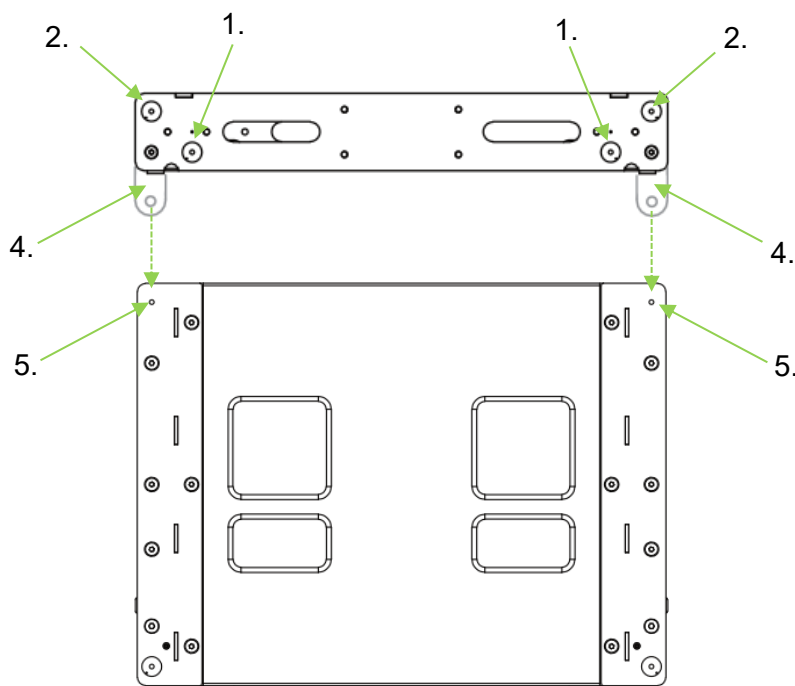

### 8.5.2 Fixing the L-118 SA flying frame under the subwoofer

- Lift the subwoofer(s) flush with the front grille onto the flying frame. Two people or suitable lifting gear are required for this. Use the labelling to ensure the correct orientation (top/bottom; front/rear). The connecting slides (1.) of the flying frame remain in the park position.
- Remove the four upper pins (2.) at the corners of the flying frame.
- Then remove the lower four plug-in bolts (3.) of the subwoofer on the flying frame. The connecting slide (4.) will slide downwards out of the housing. Then push the plug-in bolt (3.) back into its original position.
- Then make the connection with the hole in the connecting slide by inserting the upper pins (2.) of the flying frame back into their position, where the ends of the connecting slides (4.) are also inserted.

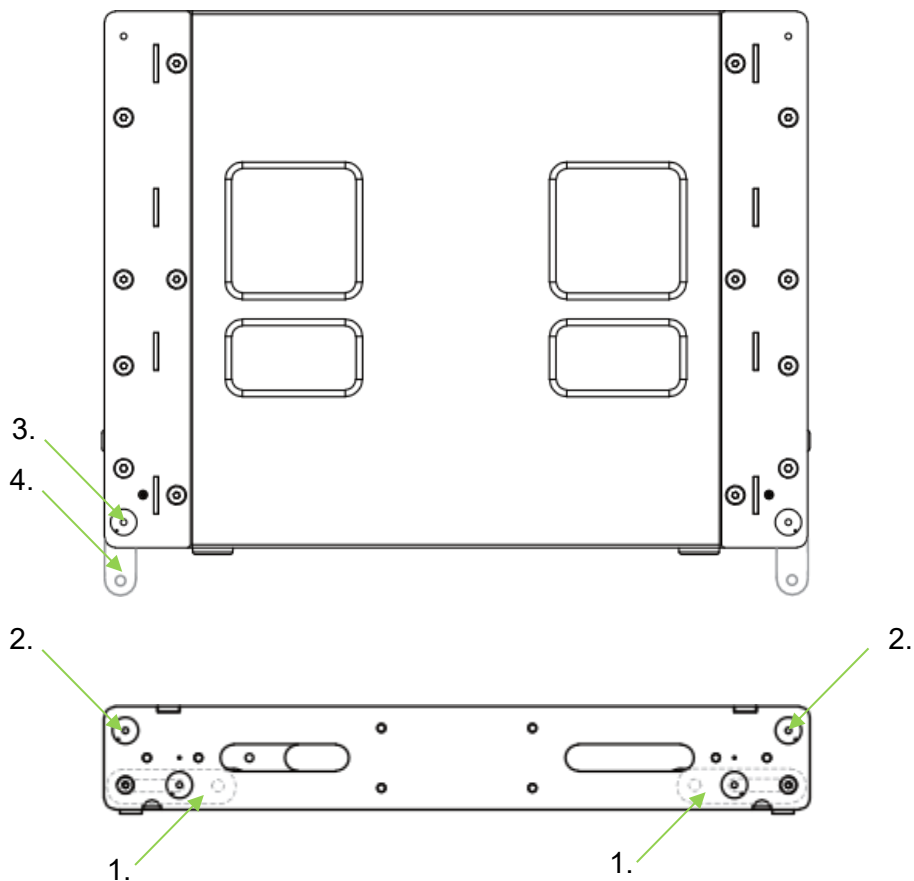

## 8.5.3 Fixing the top section under the L-118 SA flying frame of the transport dolly

- Remove the two internal front plug-in bolts (1.) in the flying frame. The connecting slides (2.) for connecting a top section fold downwards.
- Now lift the array with these connecting slides (2.) into the corresponding grooves (left and right of the front grille) of the top section of the next transport dolly.
- Fix the connecting slides through the upper holes (3.) on the front of the top section with the internal plug-in bolts (1.) of the flying frame.
- Remove the rear internal LINK pin (4.) of the flying frame
- Now push the load bar (5.) of the top section upwards, until it touches the LOCK pin (6.) of the flying frame.
- Now secure the load bracket (5.) with the LINK pin (4.).
- Remove the LOCK pins (7.) from all top sections on the transport dolly. The LINK pins (10.) always remain inserted.
- To set the desired angle, remove the angle pin (8.) from the top section underneath and slide the load bracket (9.) upwards until the groove in the load bracket matches the desired angle on the scale on the right-hand side of the mounting rail
- Then insert the angle pin (8.) from the left-hand side of the mounting rail through the hole with the desired angle
- Repeat this step accordingly with the next top sections.

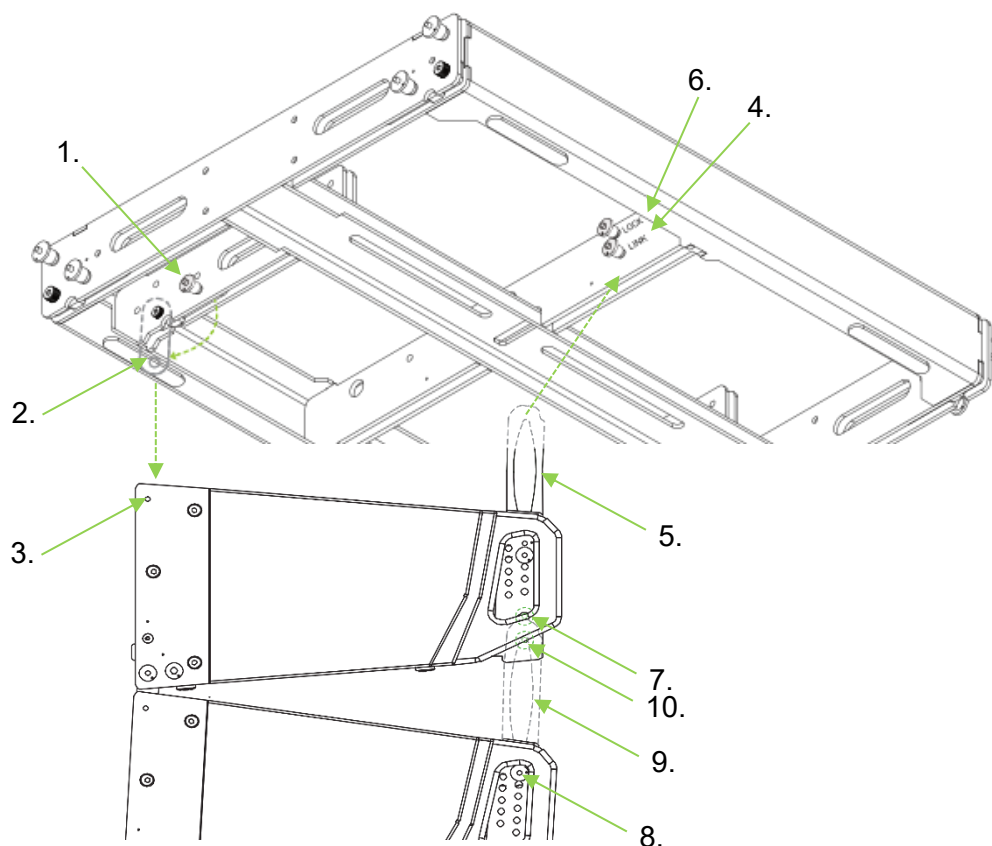

**NOTE**

To connect the uppermost top section to the flying frame, ALWAYS set 2° to achieve a 0° angle.

Follow the instructions on the flying frame!

- Now remove the three plug-in bolts (11.) that secure the top sections on the transport dolly.
- You can now lift the tops out of the dolly. This will automatically create the set angles.
- As soon as the array is under load, put all the lock pins back into position to lock the brackets in place.

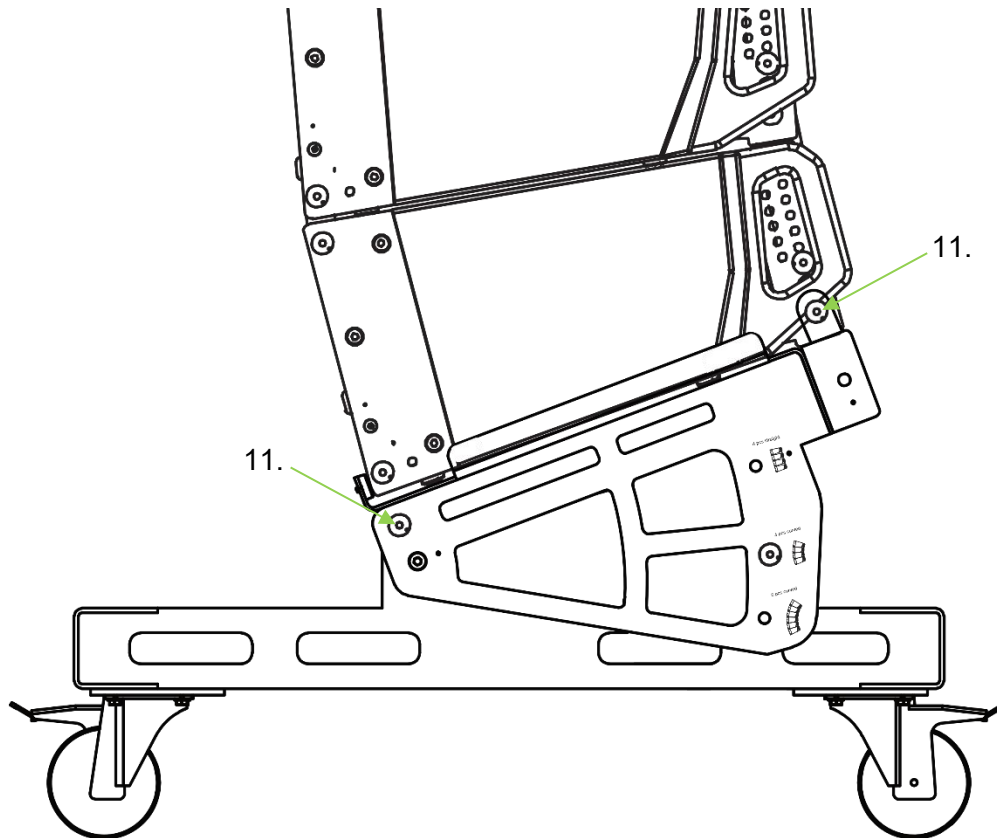

### 8.5.4 Fixing the top section to the top section of the transport dolly

- Remove the front plug-in bolts (1.) from the bottom top section of the array. The connecting slide (2.) will slide downwards out of the housing. Secure the slide directly with the plug-in bolts (1.) in the same plug-in position.
- Now lift the array with these connecting slides flush to the front into the corresponding grooves of the top section of the next transport dolly.
- Then make the connection with the hole in the connecting slide by inserting the rear pins (3.) of the lowest suspended top section into the holes (4.) on the top of the top section below, where the ends of the connecting slides (2.) are also inserted.
- Remove the LINK pin (5.) from the lowest suspended top section.
- Now push the load bar (6.) of the topmost top section on the transport dolly upwards, until it touches the LOCK pin (7.) of the lowest hanging top section.
- The load bracket (6.) can be fixed in this position with the LINK pin (5.).
- Now remove the LOCK pins (8.) from all tops on the transport dolly. The LINK pins always remain inserted.
- To set the desired angle, remove the angle pin (9.) from the top section underneath and slide the load bracket (10.) upwards, until the groove in the load bracket matches the desired angle on the scale on the right-hand side of the mounting rail (for details, see chapter 3.1.1)
- Then insert the angle pin (11.) from the left-hand side of the mounting rail through the hole with the desired angle
- Repeat this step accordingly with the next top sections.
- Now remove the three pins (12.) that secure the top sections on the transport dolly.
- You can now lift the tops out of the dolly. This will automatically create the set angles.
- As soon as the array is under load, put all LOCK pins (8.) back into position to lock the brackets.

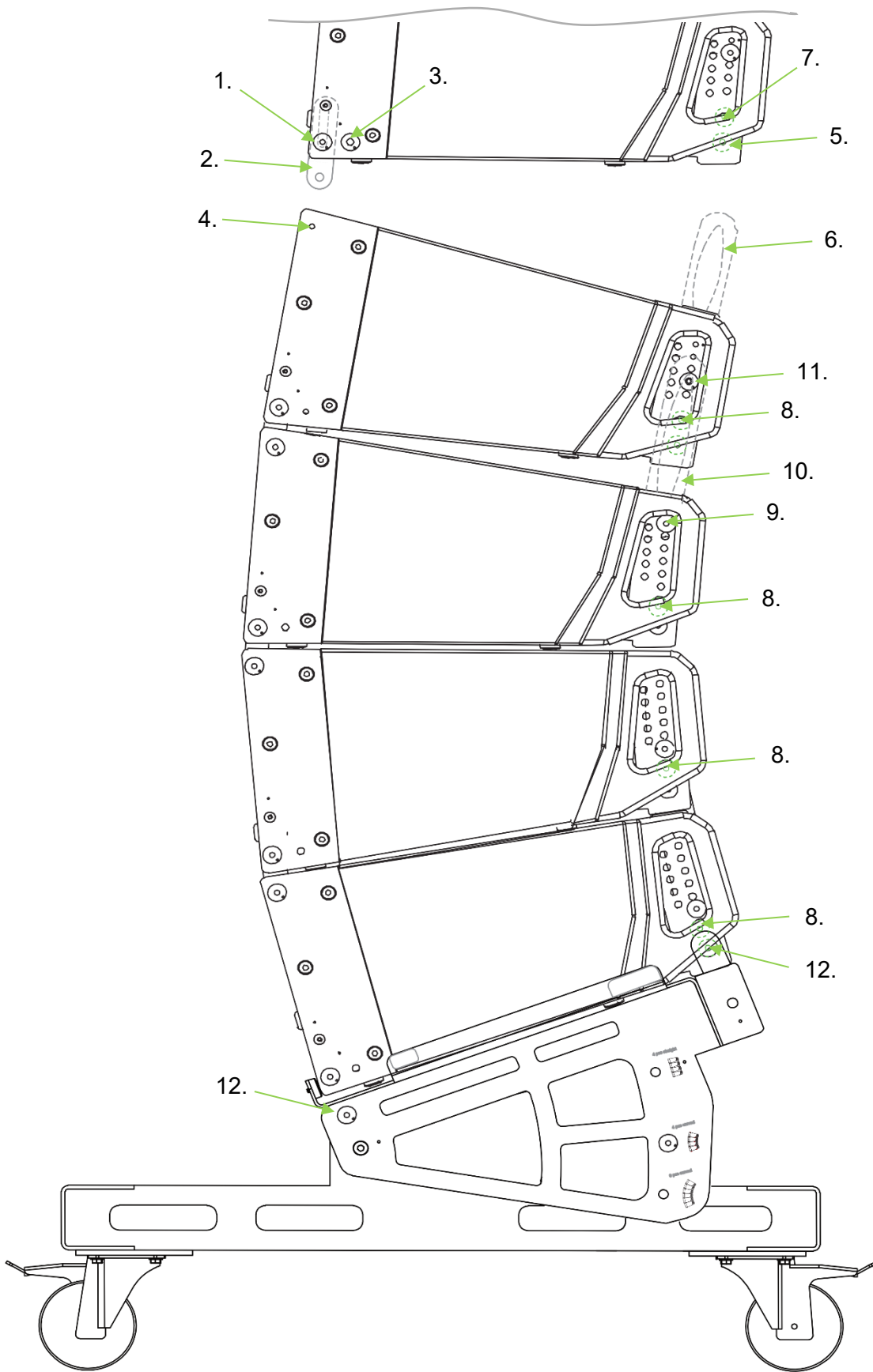

## 9 Specifications

### 9.1 XANA L-208 TA Line Array Top 1,400W

<b>Structure</b>	3-way active
<b>Frequency response</b>	65Hz - 20KHz (-10dB)
<b>Max SPL</b>	132 dB
<b>Loudspeaker</b>	2x 1.35" / 8Ω / CD horn 2x 8" neodymium / 4Ω / 2 "v.c
<b>Beam angle</b>	90° horizontal 12° vertical
<b>Amplifier power</b>	1,400 W RMS 2,800 W peak
<b>Cooling</b>	No fan, convection cooling
<b>Mains voltage</b>	220-240V / 50-Hz
<b>Controller</b>	DSP 32 bit
<b>Network</b>	RS 485 Protocol
<b>LED display</b>	Input signal, limit
<b>Signal connections</b>	Line Input 1x XLR 3-pin female, balanced Line Out 1x XLR 3-pin female, balanced
<b>Network connections</b>	DATA Input Network b. (etherCON compatible) DATA Link Netzwerk b. (etherCON compatible)
<b>Power connections</b>	Mains Input 1x PowerCON TRUE1 Mains Link 1x PowerCON TRUE1
<b>Power consumption</b>	3.7A max. (850W)
<b>Work area</b>	-5°C to 40°C   max. 5,000m above sea level
<b>Housing</b>	Birch plywood with polyurethane coating
<b>Flight system</b>	3 point
<b>Width x height x depth</b>	620 x 250 x 470 mm
<b>Weight</b>	27.5 kg

## 9.2 XANA L-118 SA line array subwoofer 2,800W

<b>Structure</b>	Active line array subwoofer, airborne
<b>Frequency response</b>	34Hz - 150Hz (-10dB)
<b>Max SPL</b>	138 dB
<b>Loudspeaker</b>	1x 18" neodymium / 4Ω / 4" v.c
<b>Amplifier power</b>	2,400 W RMS 4,800 W peak
<b>Cooling</b>	No fan, convection cooling
<b>Mains voltage</b>	220 - 240V / 50Hz
<b>Controller</b>	DSP 32 bit
<b>Network</b>	RS 485 protocol
<b>LED display</b>	Input signal, limit
<b>Signal connections</b>	Line Input 1x XLR 3-pin female, balanced Line Out 1x XLR 3-pin female, balanced
<b>Network connections</b>	DATA Input Network b. (etherCON compatible) DATA Link Netzwerk b. (etherCON compatible)
<b>Power connections</b>	Mains Input 1x PowerCON TRUE1 Mains Link 1x PowerCON TRUE1
<b>Power consumption</b>	10.3A max. (2,360W)
<b>Work area</b>	-5°C to 40°C   max. 5,000m above sea level
<b>Housing</b>	Birch plywood with polyurethane coating
<b>Flight system</b>	4 point
<b>Width x height x depth</b>	840 x 495 x 655 mm
<b>Weight</b>	71.4 kg

### 9.3 XANA L-208 TA flying frame

<b>Structure</b>	Steel construction
<b>Diameter pick point</b>	20mm
<b>Width x height x depth (without pins)</b>	622 x 84 x 520 mm
<b>Weight</b>	15.65 kg

### 9.4 XANA L-118 SA flying frame

<b>Structure</b>	Steel construction
<b>Diameter pick point</b>	20mm
<b>Width x height x depth (without pins)</b>	840 x 85 x 650 mm
<b>Weight</b>	31.81 kg

## 10 Maintenance



**DANGER**

Suspension systems consist of mechanical components and must therefore be regularly inspected and maintained to ensure their proper function and safety.

Before installing a loudspeaker system, it is essential to ensure that all components - such as the housing, flying frame, bolts, locking pins, split pins, etc. - are checked for cracks, deformation, corrosion and missing, loose or damaged parts. Such defects can significantly impair the load-bearing capacity and safety of the entire system.

A loudspeaker must not be suspended or placed on a stand until all necessary measures have been taken to rectify any defects found.

Installed systems must be inspected at least once a year. This inspection should include a visual inspection of all load-bearing components - in particular for cracks, deformation, moisture damage or other signs that could jeopardise the structural integrity of the speaker enclosure. Defective components must not be put into operation.



## 11 Cleaning

Use a lint-free and only slightly damp cloth for cleaning. Chemical cleaners may contain solvents, which can damage the surfaces.

### WEEE declaration (Waste of Electrical and Electronic Equipment)

Your product has been developed and manufactured using high-quality materials and components that are recyclable and reusable. The symbol means that your product must be disposed of separately from household waste at the end of its service life.

Dispose of this appliance at your local collection point or recycling centre.

Please help to protect the environment in which we all live.

All technical data and appearances are subject to change without prior notice. All information was correct at the time of printing. Musikhaus Kirstein GmbH accepts no liability for the accuracy or completeness of the descriptions, photos or statements contained in this manual. Printed colours and specifications may differ slightly from the product. Musikhaus Kirstein GmbH products are only sold through authorised dealers. Distributors and dealers are not representatives of Musikhaus Kirstein GmbH and are not authorised to legally bind Musikhaus Kirstein GmbH in any way.

**Musikhaus Kirstein GmbH**  
**Bernbeurener Street 11**  
**86956 Schongau - Germany**  
**Phone: 0049-8861/909494-0**  
**info@kirstein.de**

