

PRONOMIC Xana Regenschutz

Artikel 00111203 Pronomic XANA L-118 SA Regenschutz für Elektronik
Artikel 00111201 Pronomic XANA L-208 TA Regenschutz für Elektronik

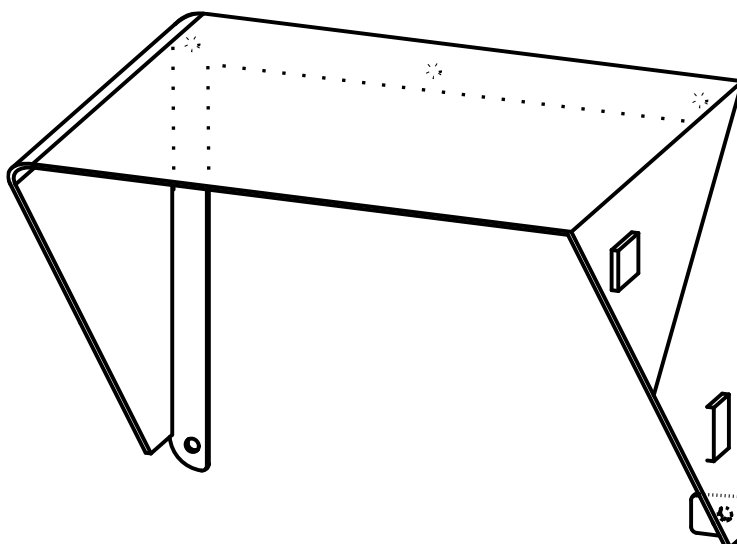

Operating instructions

Revision: 04/2026

Installation

1. Remove the screws marked with arrows
2. Insert the removed screws through the pre-drilled holes in the rain cover
3. Secure the rain cover with the screws at the marked location

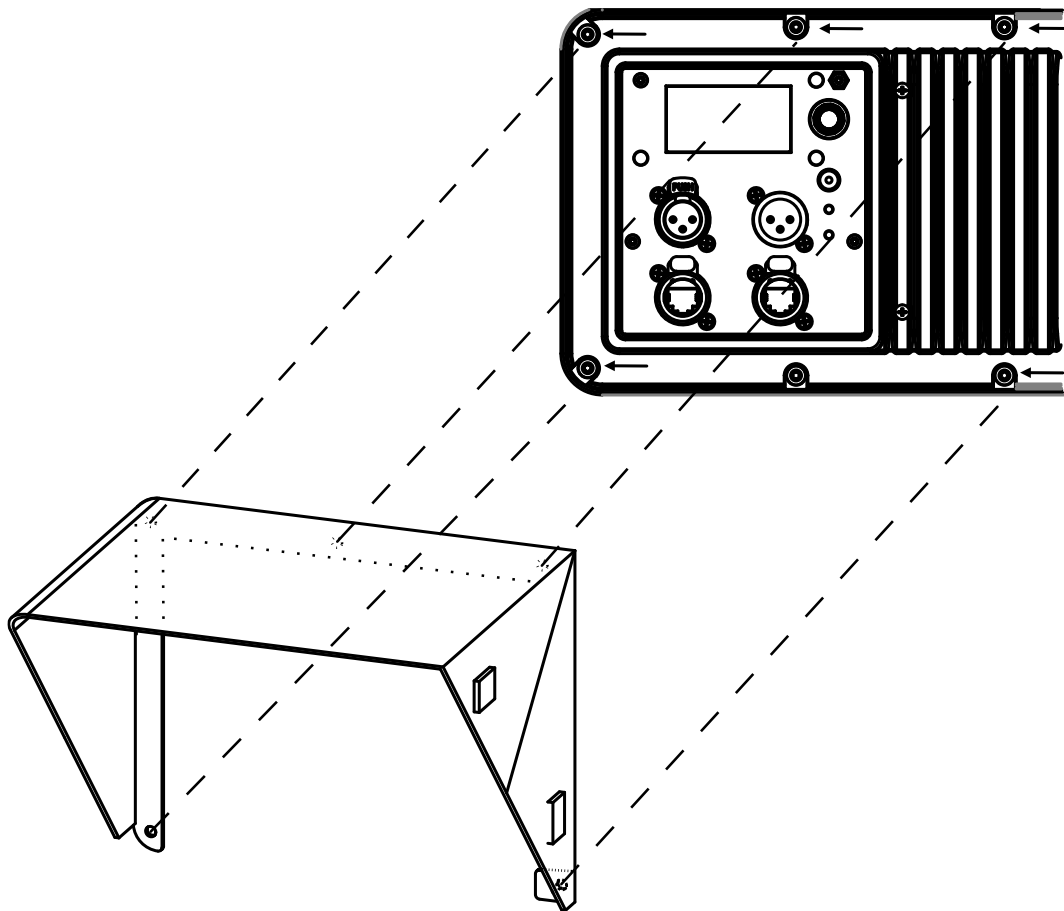

 **KIRSTEIN.de**

Musikhaus Kirstein GmbH
Bernbeurener Straße 11
86956 Schongau - Germany
Telefon: 0049-8861/909494-0
info@kirstein.de

