

VORSICHTSMASSNAHMEN (BITTE SORGFÄLTIG DURCHLESEN) Kinder sollten beaufsichtigt werden, um sicherzustellen, dass sie dieses Produkt nicht als Spielzeug verwenden. Lassen Sie Kinder niemals unbeaufsichtigt mit dem Verpackungsmaterial spielen. **Warnhinweise:** Stellen Sie das Produkt stets auf eine geeignete Oberfläche ab, um ein Wackeln oder Umfallen zu verhindern. **Vorsichtsmaßnahmen:** Um Schäden am Produkt zu vermeiden, stellen Sie es nicht an Plätze mit hohen Temperaturen oder viel Staub, stellen Sie es nicht direkt neben eine Klimaanlage und vermeiden Sie direkte Sonneneinstrahlung. Wenden Sie im Umgang mit dem Produkt keinerlei Gewalt an und stellen Sie keine zu schweren Gegenstände darauf. **Ort:** Setzen Sie das Produkt nicht den folgenden Bedingungen aus, um Verformungen, Verfärbungen oder größere Schäden zu vermeiden: Direktes Sonnenlicht, extreme Temperatur oder Luftfeuchtigkeit, übermäßig staubiger oder schmutziger Ort, starke Vibrationen oder Stöße. **Reinigung:** Reinigen Sie das Produkt nur mit einem weichen, trockenen Tuch. Verwenden Sie keine Farbverdünner, Lösungsmittel, Reinigungsflüssigkeiten oder chemisch imprägnierte Wischtücher. **Handhabung:** Üben Sie keine übermäßige Kraft auf Bedienelemente wie z.B. Schalter, Knöpfe aus. Technische Änderungen und Änderungen im Erscheinungsbild sind vorbehalten. Alle Angaben entsprechen dem Stand bei Drucklegung. Für die Richtigkeit und Vollständigkeit der enthaltenen Beschreibungen, Abbildungen und Angaben übernimmt Musikhaus KIRSTEIN GmbH keinerlei Gewähr. Abgebildete Farben und Spezifikationen können geringfügig vom Produkt abweichen. Musikhaus KIRSTEIN GmbH - Produkte sind nur über autorisierte Händler erhältlich. Distributoren und Händler sind keine Handlungsbevollmächtigten von Musikhaus KIRSTEIN GmbH und haben keinerlei Befugnis, die Musikhaus KIRSTEIN GmbH in irgendeiner Weise, sei es ausdrücklich oder durch schlüssiges Handeln, rechtlich zu binden. Diese Bedienungsanleitung ist urheberrechtlich geschützt. Jede Vervielfältigung, bzw. jeder Nachdruck, auch auszugsweise, und jede Wiedergabe der Abbildungen, auch in verändertem Zustand, ist nur mit schriftlicher Zustimmung der Firma Musikhaus KIRSTEIN GmbH gestattet.

PRECAUTIONS (PLEASE READ CAREFULLY) Children should be supervised to ensure that they do not use this product as a toy. Never let children play with the packaging material unsupervised. **Warning:** Always place the product on a suitable surface to prevent it from wobbling or falling over. **Precautions:** To avoid damage to the product, do not place it in places with high temperatures or a lot of dust, do not place it directly next to an air conditioner and avoid direct sunlight. Do not use force when handling the product and do not place objects that are too heavy on it. **Location:** Do not expose the product to the following conditions to avoid warping, discoloration, or major damage: direct sunlight, extreme temperature or humidity, excessively dusty or dirty location, strong vibration or shock. **Cleaning:** Only clean the product with a soft, dry cloth. Do not use paint thinners, solvents, cleaning fluids, or chemically impregnated wipes. **Handling:** Do not exert excessive force on controls such as switches, buttons. Technical changes and changes in appearance are reserved. All information corresponds to the status at the time of printing. Musikhaus KIRSTEIN GmbH assumes no liability for the correctness and completeness of the descriptions, illustrations and information contained. Shown colors and specifications may differ slightly from the product. Musikhaus KIRSTEIN GmbH - Products are only available through authorized dealers. Distributors and dealers are not authorized representatives of Musikhaus KIRSTEIN GmbH and have no authority to bind Musikhaus KIRSTEIN GmbH legally in any way, be it expressly or through coherent action. This manual is protected by copyright. Any duplication or reprint, even in part, and any reproduction of the images, even in a modified state, is only permitted with the written consent of Musikhaus KIRSTEIN GmbH.

CLASSIC CANTABILE

GP-A 810 Digital Grand



User manual

Item 00055903, 00055904
Version 01/2019_2

Thank you for choosing the **Classic Cantabile GP-A 810**. We hope you enjoy your new **Classic Cantabile GP-A 810**.

Please read these instructions carefully to ensure that you can make full use of the practical features of the Classic Cantabile GP-A 810.

We also recommend that you keep this manual in a safe and easily accessible place for future reference.

Attention!

Before switching on and using the device for the first time, be sure to read the safety instructions to avoid injury and damage to the device.

Safety instructions

Please read these instructions before operating the device and keep them in a safe place. Follow the safety instructions to prevent damage or injury from electricity, short circuits, or fire. This includes the following:

Do not remove the housing or rear panel; there are no parts inside the device that you can service yourself. If repairs are necessary, please contact a qualified repair shop.

- Do not expose the device to rain or other moisture, and avoid operating it in damp or wet conditions. Do not place any liquid-filled containers on top of the device to prevent splashes from entering the device.
- If the power cord or plug is damaged, if there is a loss of sound during use of the piano, if you notice an unusual smell or if smoke is emitted, please switch off the device immediately, disconnect it from the power supply and take it to a qualified repair shop.
- Only use voltages for which the device is approved. This is indicated on the type plate of the piano.
- Always disconnect the device from the power supply before cleaning it. Never touch the plug or the socket with wet hands!
- Please check the condition of the plug regularly and remove any dirt or dust that may have accumulated on it.

Precautions

- Do not place the power cord near heat sources such as radiators or heaters, do not bend it excessively, do not place heavy objects on it, and take care not to damage it in any other way. Lay it so that no one can trip over it or step on it and so that no objects can roll over it.
- If you wish to disconnect the device from the power supply, always pull on the plug and never on the cable.
- Do not operate the piano from a multiple socket, as this may result in sound loss, overloading or overheating of the socket.
- Disconnect the piano from the power supply if you do not intend to use it for a long period of time and always during a thunderstorm.
- Before connecting the piano to other devices, always switch off all devices, turn all volume controls to minimum, and then switch on the devices.
- Do not expose the device to excessive dust or vibrations, heat or cold, or direct sunlight, and do not leave it in the car during the day. This will prevent discoloration and damage to the surface as well as damage to the electronics.
- Do not use the piano near televisions, radios, or speakers to avoid interference that could disrupt the operation of the piano.
- Do not place the piano on uneven ground, as this will make it unstable and it may tip over.
- Before transporting the piano, please disconnect all cables.
- If you wish to clean the device, please use a dry, soft cloth. Do not use thinners, solvents, other cleaning fluids, or chemically impregnated cloths. Do not place any vinyl products on the piano, nor any plastic or rubber objects. This could discolor the surface of the piano.
- Do not sit on the piano or place heavy objects on it.
- Do not use force when handling buttons, keys, and plugs.
- Be careful not to trap your fingers in the key cover. Never put your fingers in the gap between the cover and the keyboard!
- Make sure that no objects of any kind get into the gap between the cover and the keyboard. If this happens, disconnect the device from the power supply and take it to a qualified repair shop for inspection.
- Keep a distance of 3 cm between the wall and the piano. This is important for air circulation, which prevents the piano from overheating.
- Read the chapter on assembly and initial operation carefully, as improper assembly may result in injury or damage to the device.
- Do not operate the piano at high volume for long periods of time, as this may cause hearing loss, which may be permanent. If you suspect that your hearing is impaired or if you hear noises such as ringing or whistling, please consult a doctor.
- Switch off the device during a thunderstorm and disconnect it from the power outlet.

Safety instructions (brief overview)

Please read the following section carefully before using the instrument! Please keep this operating manual in a safe place.

Power supply

Please connect the supplied power supply unit to a power outlet with the correct voltage. Do not connect the device to a power outlet that is not suitable for the device. Disconnect the power supply unit from the power supply when you are not using the instrument or during a thunderstorm.

connections

Before connecting the instrument to other devices, please switch off all devices first. This will protect the devices from damage and help prevent malfunctions.

Environment

To prevent deformation, discoloration, or more serious damage, do not expose the device to the following conditions:

- direct sunlight
- extreme temperatures
- extreme humidity
- dust or dirt
- strong vibrations or shocks - magnetic fields.

Interference

If radio or television sets are located near the instrument, interference may occur. If this is the case, please move the devices further apart.

Cleaning

Please clean the instrument only with a soft, dry cloth. Do not use paint thinners, solvents, cleaning fluids, or chemically impregnated cleaning cloths.

Handling

Please do not use excessive force when handling buttons and switches and ensure that no paper, metal, or other objects can get into the instrument. If this happens, please disconnect the device from the power supply immediately and take it to a specialist dealer for inspection.

Always disconnect all cables before moving the instrument!

Table of contents

Power supply	3
connections	3
Environment	3
Interference	3
Cleaning	3
Handling	4
Assembly	6
Display & control unit	11
Front control unit	11
LCD display	13
Connections	14
Power	15
Adjusting the volume	15
Adjusting the brilliance	15
Playing demo songs	16
Selecting a voice	16
Two voices simultaneously	16
Different voices on both hands	17
Transpose	17
Piano mode	17
Twinova	18
Automatic accompaniment	18
Accompaniment plays only the rhythm	18
Playing entire songs in a style	19
Accompaniment variations	19
Adjusting the speed	20
One-touch setting	20
Equalizer	21
DSP effect	22
Harmony	23
Playing with the harmony function	23
Setting the harmony variation	23
Function menu	23
Voice settings	24
Octave shift	24
Touch sensitivity	24
Chord type setting	24
Changing the split point	24
Twinova Split Point / Octave Shift	25
Harmony variant	25
Equalizer	25
String resonance	25
Soft Pedal	26
Freeze	26
Metronome beat and tone	26
Fade setting	26
MIDI Out Channel	27
Song Loop (continuous loop)	27
Auto Standby (APO)	27
System time settings	27
Automatic Bluetooth connection	28
Resetting to factory settings	28
Performance Memory	28
Setting the panel	28
Recalling settings	29
Selecting a memory bank	29
Making certain settings unchangeable (freeze function)	29
Recording a song	29
MIDI recording	29

Preparing to record	30	Loading a file from USB.....	35
Starting recording.....	30	Formatting the USB stick	35
Stop recording.....	30	MIDI	35
Playing back a recording.....	30	What is MIDI?	35
Recording settings	31	Troubleshooting	36
Audio recordings	32	Specifications	37
Preset songs	32	Appendix	39
Playing songs	32	Voice list.....	39
Song playback settings	33	Style list.....	50
Practicing songs.....	33	51
Bluetooth	33	Song list.....	52
Playing Bluetooth songs	33	Demo song list	52
Ending the Bluetooth connection.....	34	Chord list.....	53
Connecting a USB flash drive	34	MIDI Implementation Table.....	54
Playing files from a USB stick.....	34	WEEE/CE Declaration	55
Saving files to a USB stick	34		

Assembly

Before assembly, please check that all parts shown in the illustration are included in the package. If any parts are damaged or missing, please contact Musikhaus KIRSTEIN customer service.

A	Pedal bracket
B	Right stand
C	Left stand
D	Rear stand foot
E	Piano body
F	Washer
G	M12x45mm hexagon screw
H	Ø3x15mm screw
I	Copper rod
J	Wrench

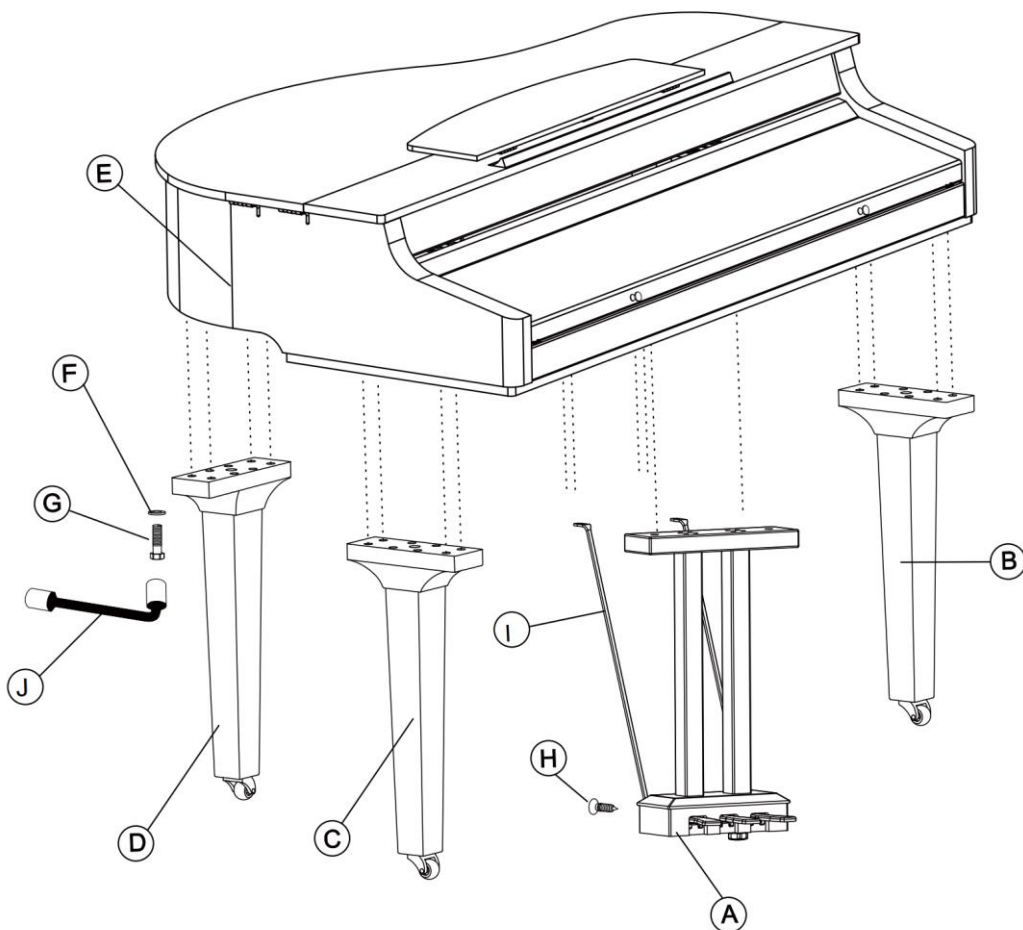

Now follow the instructions to attach the legs to the piano. You will need a Phillips screwdriver, which is not included in the delivery.

A) Turn the box upside down so that the bottom of the box is facing up and open the box. Remove the protective foam from the piano.

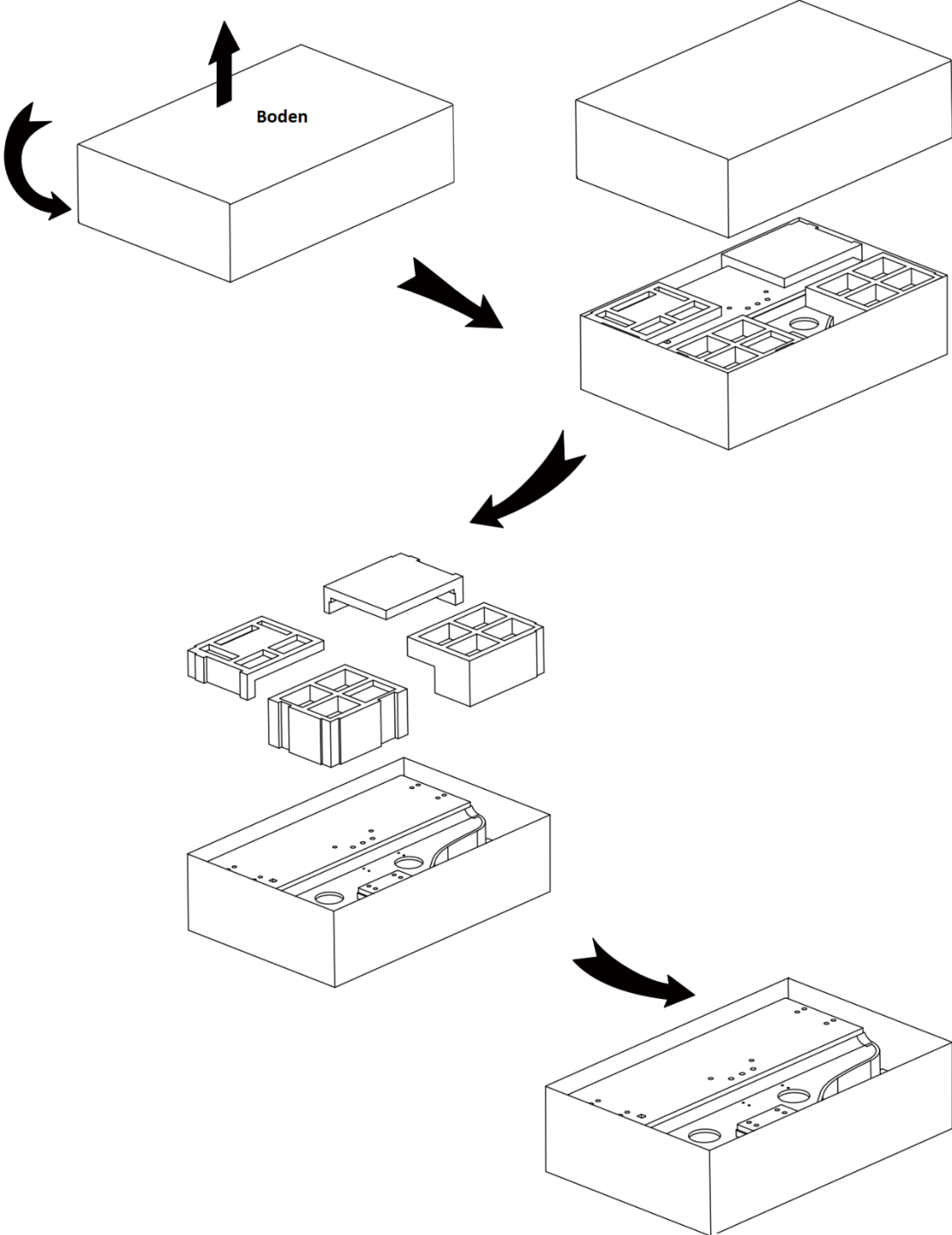

B) Place the left foot (C) on the left side of the piano body. Then align the pre-drilled holes so that they match those on the piano. Next, place a washer on each screw (G 2x) and tighten them with the wrench.

Repeat this step to mount the right and rear feet.

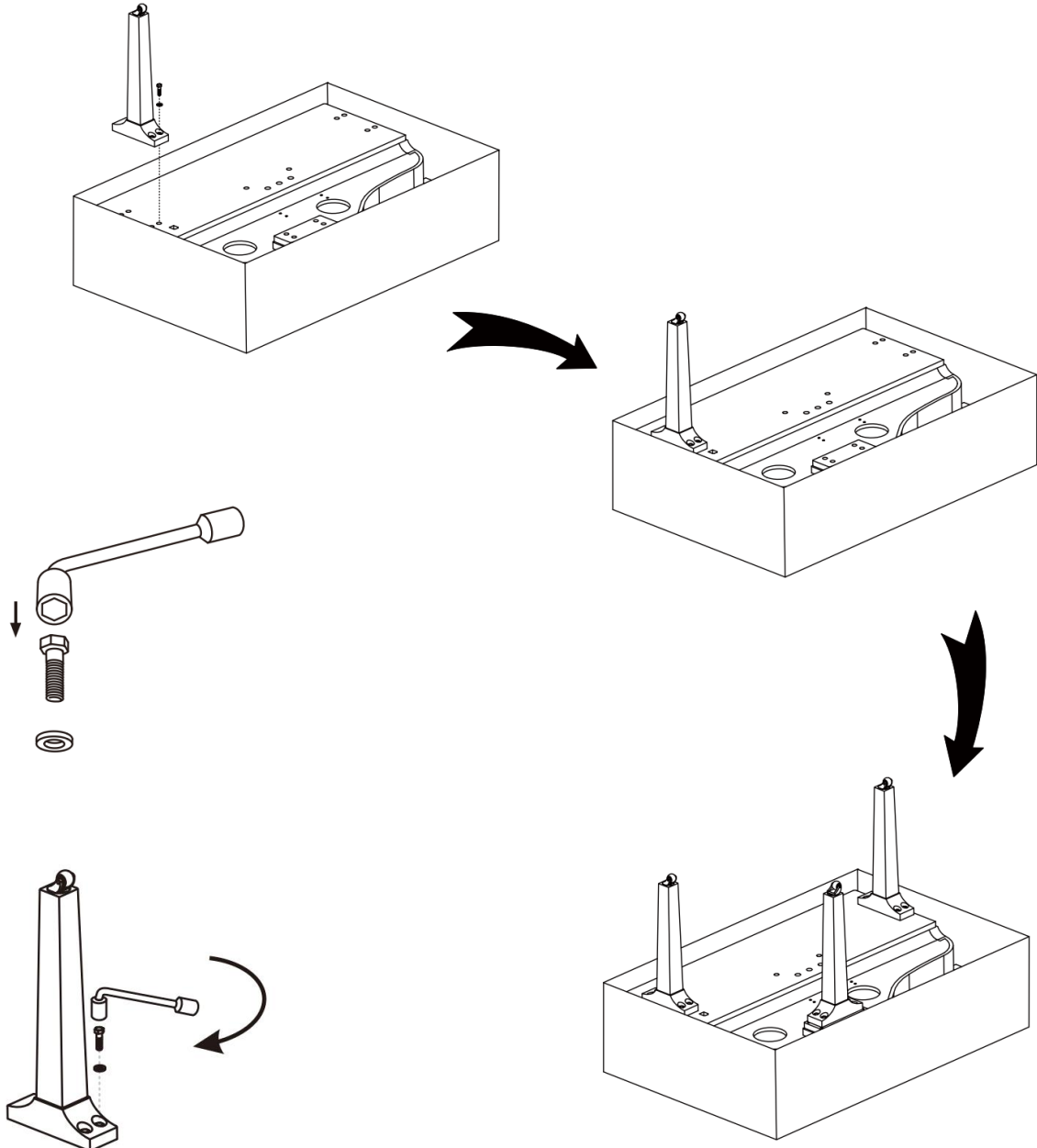

C) Use the screws (H) to attach the two copper rods to the rear of the pedal bracket.

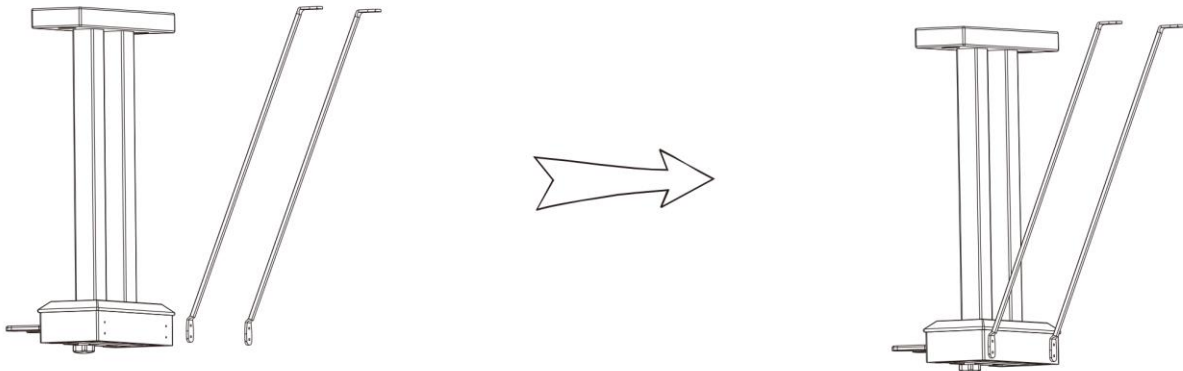

D) Then place and secure the pedal bracket on the underside of the piano body.

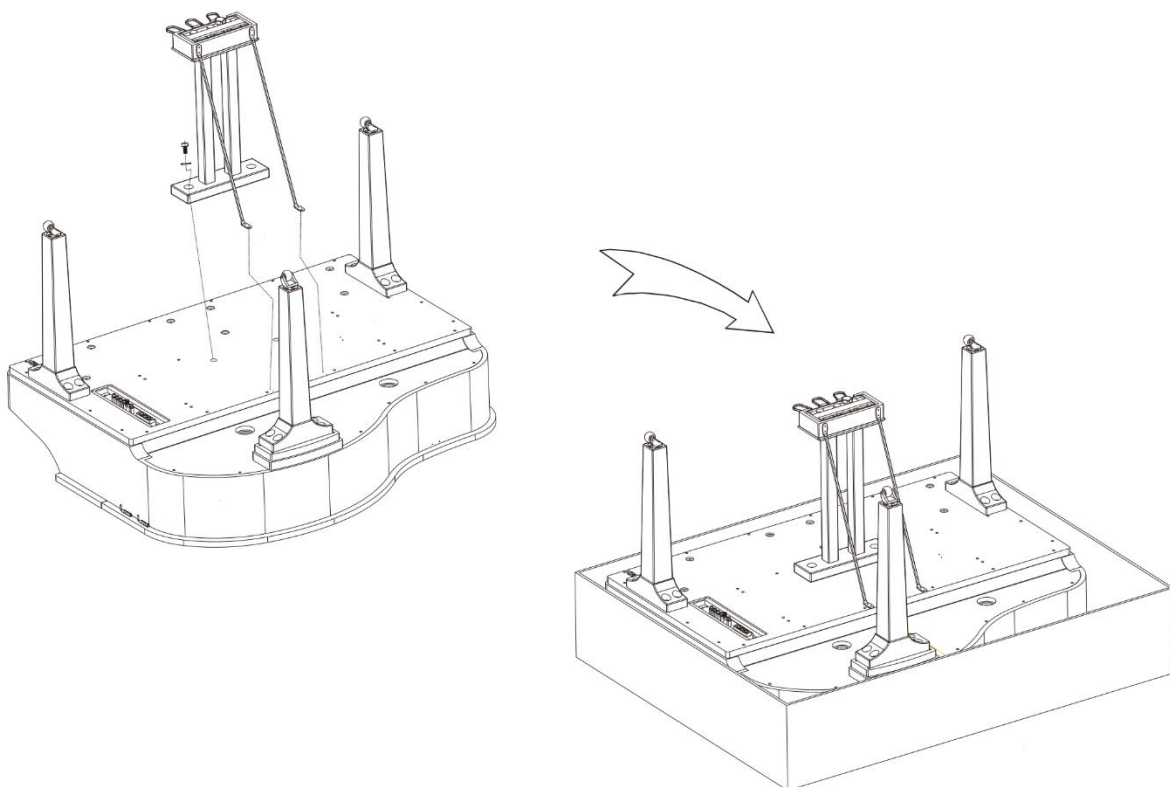

E) Now you can turn the piano over.

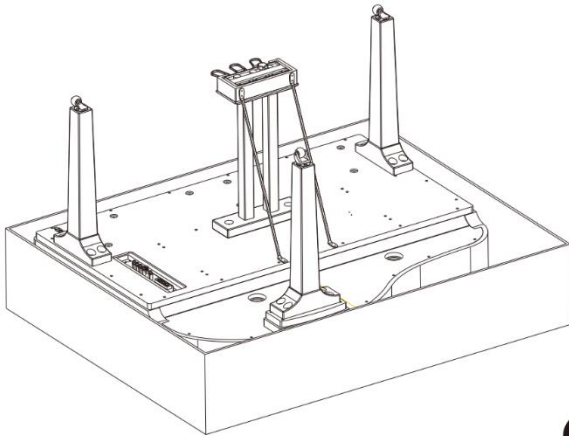

1

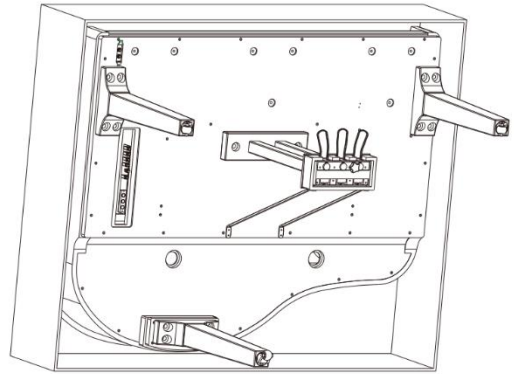

2

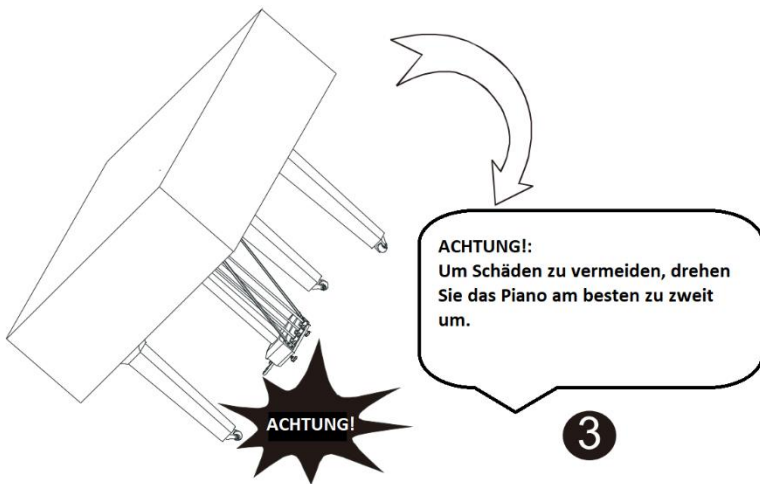

3

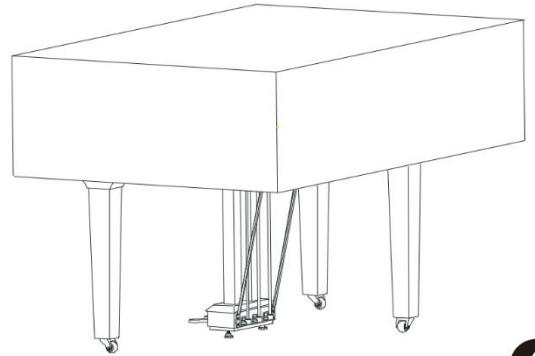

4

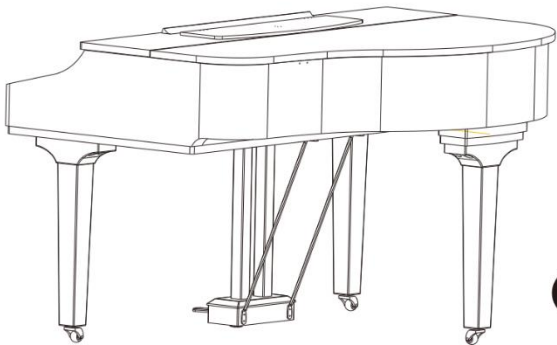

5

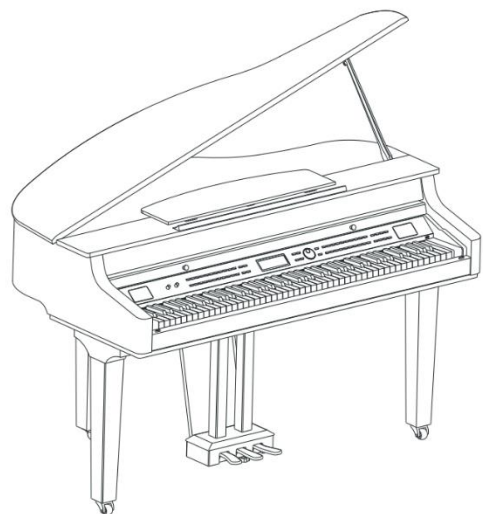

6

Display & control unit

Front control unit

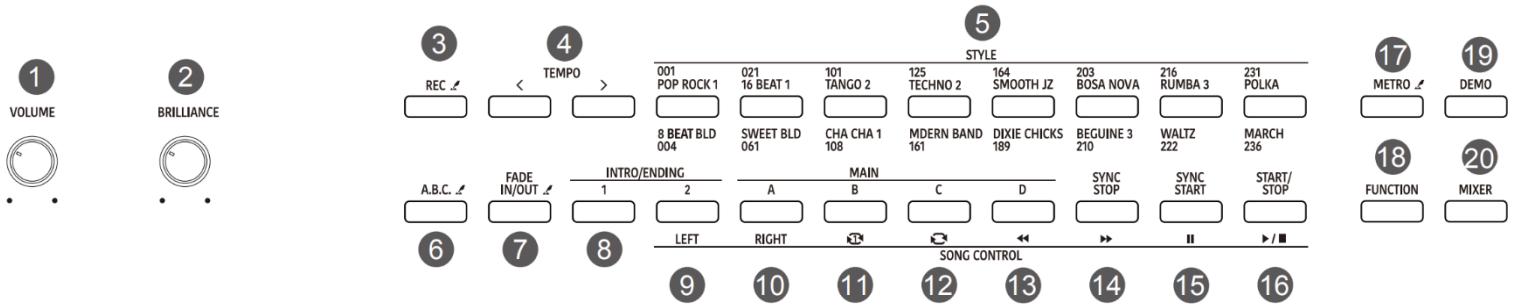

1. Volume control

Adjust the volume here.

2. Brilliance control

Use this to adjust the brilliance or brightness of the sound.

3. Recording button

With USB stick inserted: Press to start audio recording.

Without USB stick: Press to start MIDI recording. Press and hold the button to access the settings.

4. Tempo (+/-) buttons

Use these buttons to adjust the speed.

5. Style selection button

Select a style here. Press the button once to select a primary style and press the button again to select a secondary style.

6. A.B.C. button

Press this button to turn the A.B.C. function on or off.

Press and hold the button to access the chord settings.

7. Fade in/out button

Press this button to turn fade in or fade out on or off.

Press and hold the button to access the fade function settings.

8. Intro/Ending 1 button

Plays the intro or ending 1 pattern.

9. Intro/Ending 2 button

Plays the intro or ending 2 pattern.

10. Main A button

In style mode: Plays the main pattern A.

In song mode: Turns the right hand on/off.

11. Main B button

In Style mode: Plays the main pattern B.

In song mode: Plays the current song in a continuous loop.

12. Main C button

In Style mode: Plays the main pattern C.

In song mode: Plays all songs in a continuous loop.

13. Main D button

In Style mode: Plays the main pattern D.

In song mode: Plays the current song from the beginning.

In Bluetooth mode: Plays the previous Bluetooth song.

14. Sync Stop button

In Style mode: Turns the Sync Stop function on or off.

In Song mode: Fast-forwards the current playback.

In Bluetooth mode: Plays the next Bluetooth song.

15. Sync Stop button

In Style mode: Turn the Sync Stop function on or off.

In Song mode: Pause playback.

In Bluetooth mode: Pause Bluetooth playback.

16. Start/Stop button

Start/stop playback of a song (including Bluetooth).

17. METRO button

Press the button to activate the metronome.

Press and hold the button to access the settings.

18. FUNCTION button

Press the button to access the function menu.

19. Demo button

Press the button to enter demo mode.

20. Mixer button

Press the button to access the mixer menu.

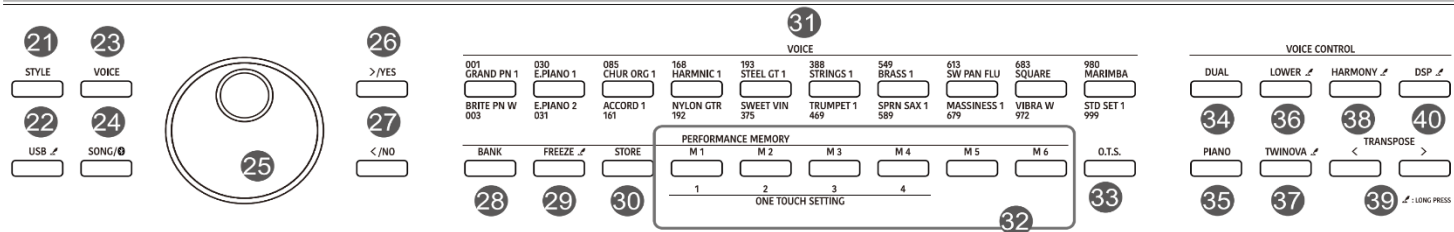

21.STYLE button

Press this button to activate style mode.

22.USB button

This button activates USB mode. Press and hold the button to access the USB menu.

23.VOICE button

Press the button to activate voice mode.

24.SONG/BLUETOOTH button

When Bluetooth is disabled, press the button to activate song mode.

When Bluetooth is enabled, press the button once to activate Bluetooth mode and press it again to switch to song mode.

25.DATA knob

Use this to adjust parameters.

26.+ /YES button

Increases the value of a parameter. Press [+ /YES] and [- /NO] simultaneously to restore the default values.

27.- /NO button

Decreases the value of a parameter. Press [+ /YES] and [- /NO] simultaneously to restore the default values.

28.BANK button

Select a memory bank

29.FREEZE button

Press the button to turn the freeze function on or off.

Press and hold the button to enter the settings.

30.STORE button

Save the current settings to a memory location.

Press STORE and M1 simultaneously to save the settings to M1.

31.VOICE Select buttons

This allows you to select a pre-installed voice directly. Press the button once to select the primary voice and press the button again to select a secondary voice.

32.M1-M6 buttons

In memory mode: Load settings from the corresponding memory location.

In O.T.S. mode: Load voices that match the current style.

33.O.T.S. button

Press this button to turn One Touch Setting on or off.

34.DUAL button

Press the button to turn dual mode on or off.

35.PIANO button

Press this button to activate piano mode.

36.LOWER button

Press this button to turn the LOWER function on or off. Press and hold this button to access the split point settings.

37.TWINOVA button

Press the button to activate or deactivate the Twinova function. Press and hold this button to access the Twinova split settings.

38.HARMONY button

Press the button to turn the Harmony function on or off.

Press and hold this button to access the Harmony settings.

39.TRANSPOSE +/- buttons

Adjust the transpose values.

40.DSP button

Press the button to turn DSP on or off. Press and hold the button to access the DSP settings.

LCD display

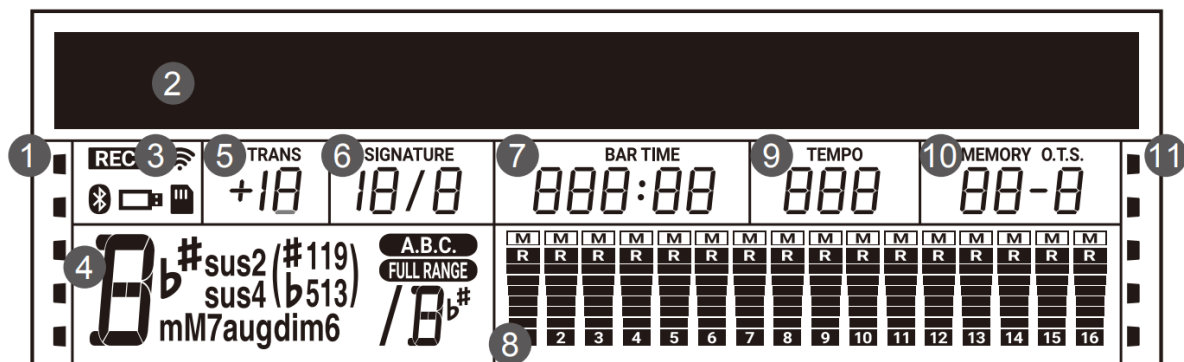

- | | |
|--|---|
| <ol style="list-style-type: none"> 1. Function display 2. 192x16 dot matrix LCD 3. Function display 4. Chord 5. Transpose 6. Time 7. Timedisplay/time measurement | <ol style="list-style-type: none"> 8. Shows volume during song playback (MIDI) 9. Tempo 10. Memory/O.T.S. 11. Functions display |
|--|---|

Connections

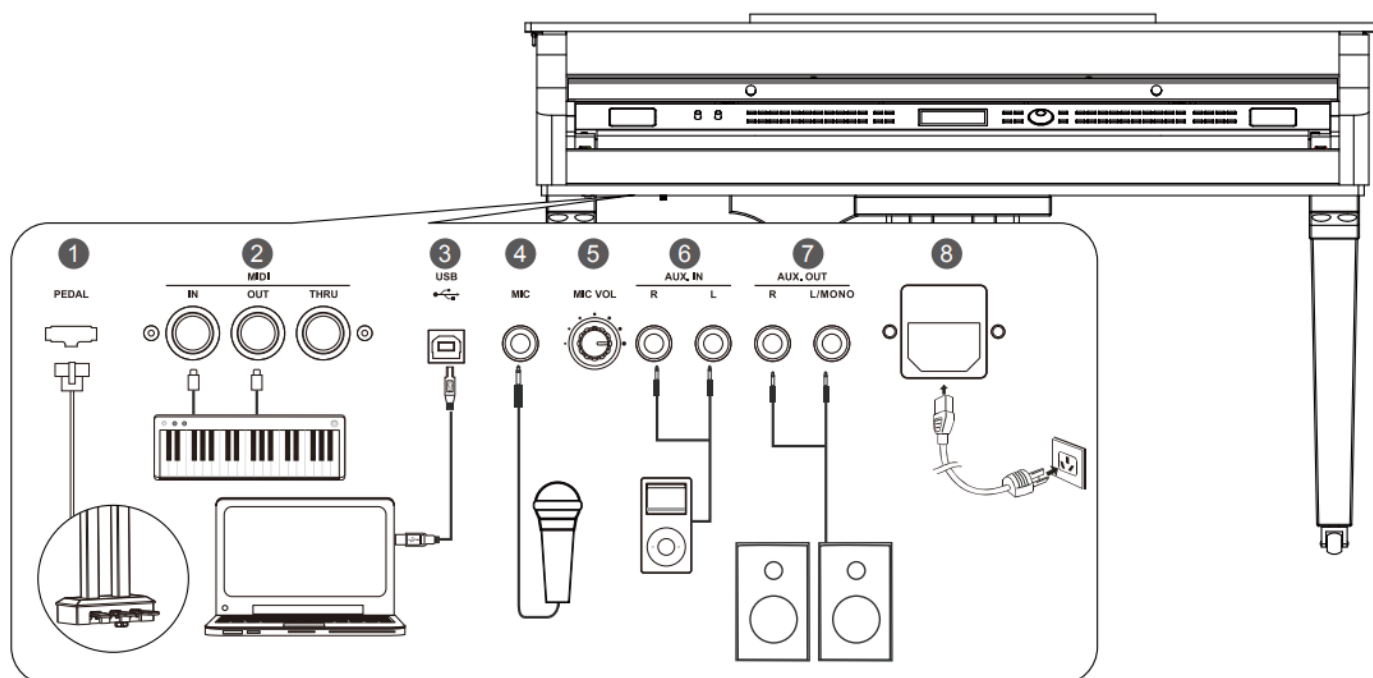

1. Pedal jack

Connect your pedal here.

2. MIDI OUT / MIDI IN / MIDI THRU jacks

You can connect external MIDI drives to the piano's jacks using standard MIDI cables.

The MIDI IN jack receives MIDI data from an external drive, while the MIDI OUT jack transmits MIDI data generated by the piano.

MIDI (Musical Instrument Digital Interface) is an international standard format for communication between electronic musical instruments. This means that all devices that have a MIDI terminal, e.g. electronic instruments or computers, can easily exchange data with each other without having to convert it.

3. USB socket

Here you can connect your keyboard to your computer, for example, to transfer songs or play the keyboard through your PC speakers.

4. Microphone jack

Before connecting your microphone, please ensure that the volume control is set to 0, as otherwise very loud noise may occur.

5. Microphone volume control

Use this to adjust the volume of the microphone.

6. AUX IN jack

This connection allows the piano to play sounds, songs, and other audio from the connected device through the speakers. Use an audio cable and connect it to the AUX IN connection on the piano and the "Output" connection on your device (e.g., MP3 player).

7. AUX OUT jack

This connection is used if you want to connect a more powerful external audio source (e.g., amplifier). Use an audio cable and connect it to the AUX OUT connection on the piano and the "Input" connection on the external device.

8. Power connection

Connect the supplied power supply unit here.

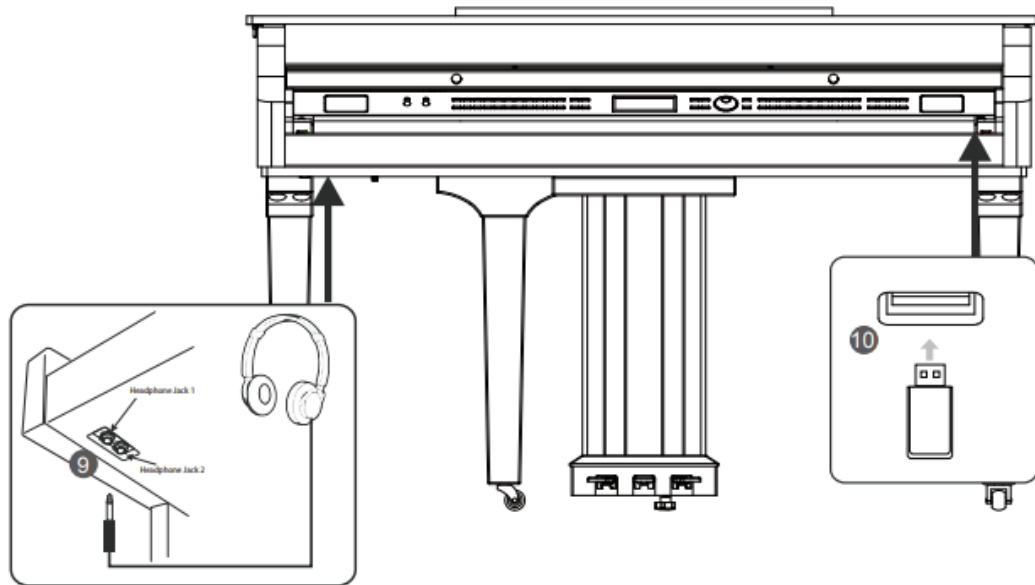

9. Headphone jack

Plug your headphones in here. The built-in speakers in the piano will automatically turn off when headphones are connected.

10. USB port

Connect your USB stick here to load or save files.

Power

1. Before switching on, check that the on/off switch is set to "Off" and that the volume controls are set to "0".
2. Connect the power supply to the piano and to a 230V power outlet.
3. Press the POWER button

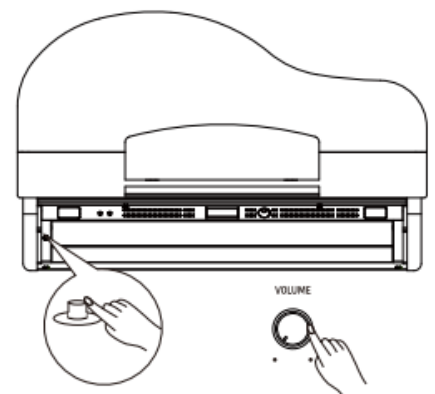

Adjusting the volume

Turn the knob to adjust the volume. Note: Excessive volume can damage your hearing over time.



Adjusting the brilliance

Brilliance determines the timbre of the piano. The more brilliance is added, the more dominant the sound of the piano becomes. This setting can also be adjusted using the rotary wheel.



Playing demo songs

The piano offers a variety of demo/learning songs that you can use for learning or just for fun.

1. Press the DEMO button.
2. Use +/YES or -/NO to select the desired song.
3. Press START/STOP to stop playback.

Note: Note entry is disabled during playback.

Selecting a voice

This piano has the ability to sound like high-quality acoustic pianos/grand pianos and at the same time sound like other instruments such as drums.

1. Press VOICE.
2. Use +/YES or -/NO to select the desired song.
3. Play with the selected voice

Two voices simultaneously

1. Activate the DUAL function using the DUAL button.
2. Select the desired song using +/YES or -/NO (shown as R2 on the display).
3. Play with the voices.
4. Deactivate the DUAL function by pressing the DUAL button again.

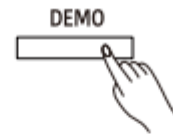

Demo 01		Demo 1			
TRACK	BEATS/MEAS	START TIME	TEMPO	MEMORY	
0	4/4	005:04	118	01-1	
[Bar graph showing volume levels]					

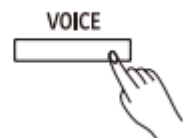

Voice R1 001		Grand Piano 1			
TRACK	BEATS/MEAS	START TIME	TEMPO	MEMORY	
0	4/4	001:01	096	01-1	

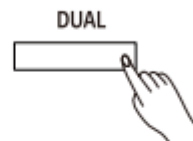

Voice R1 R2 034		Modern EP 2			
TRACK	BEATS/MEAS	START TIME	TEMPO	MEMORY	
0	4/4	001:01	096	01-1	

Different voices on both hands

Here, the piano is divided into two halves. Each half can use its own voice.

1. Press LOWER. The display now shows "L."
2. Select a voice using the data control wheel.

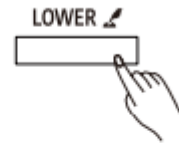

Voice		R1R2	Electric Grand 3		
	026				
TRANS	0	BEAT/ME	4/4	START	00 1:0 1
		TRIMS	096	MEMORY	0 1- 1

3. Changing the split point

Press and hold the LOWER button to enter the menu. You can then use the +/- buttons (or by pressing the desired point) to reset the split point. The default point can be set by pressing + and - simultaneously.

Func		LOWER SPLIT			F#3
	0				
TRANS	0	BEAT/ME	4/4	START	00 1:0 1
		TRIMS	096	MEMORY	0 1- 1

Default Lower Split



4. Press the VOICE button to activate or deactivate R2 and L.

Transpose

This function allows you to change the pitch of the piano in semitone steps to match other instruments or singers. This makes it easy to change the key without having to adjust your fingering. For example, if Transpose F is selected, an F will sound when you play a C. In other words, you can play the piece in C major and hear it transposed to F major.

1. Press Transpose+ / Transpose- to adjust the value.
2. Pressing + and - simultaneously restores the default value.

Piano mode

This mode is specifically designed for piano players, allowing the digital piano to reproduce the sound and feel of an acoustic piano.

1. Press PIANO to activate/deactivate the mode.

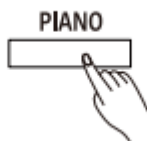

Concert Grand					
	0				
TRANS	0	BEAT/ME	4/4	START	00 1:0 1
		TRIMS	096	MEMORY	0 1- 1

Twinova

This mode divides the piano into two identical sections, allowing two people to play together.

1. Press TWINOVA. The default split point is E3.
2. To change this, press and hold TWINOVA and then press the desired split point.
3. The default point can be set by pressing + and – simultaneously.
4. Press and hold TWINOVA and then select TWINOVA OCTAVE to shift the octaves using +/-.

Note: The pedal functions change as follows in this mode:

Right pedal: Notes in the right range sound longer.

Middle pedal: Notes in both ranges sound longer.

Left pedal: Notes in the left range sound longer.

Automatic accompaniment

This function provides you with a complete band or orchestra as accompaniment. Depending on the chords you play with your left hand, the automatic accompaniment adjusts itself automatically. The instrument has a wide selection of styles. Try out different ones; you will find a list of available styles in the appendix.

Accompaniment plays only the rhythm

1. Press STYLE.
2. Use +/- to select the desired style.
3. Press Start/Stop to start or stop the automatic accompaniment.



Twinova					
TRACK	BEAT/MEASURE	START TIME	TEMPO	MEMORY	
0	4/4	00 1:01	096	01-1	

Func TWINOVA SPLIT					E3
TRACK	BEAT/MEASURE	START TIME	TEMPO	MEMORY	
0	4/4	00 1:01	078	01-1	

Func TWINOVA OCTAVE					0
TRACK	BEAT/MEASURE	START TIME	TEMPO	MEMORY	
0	4/4	00 1:01	078	01-1	

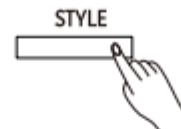

Style 002		Pop Rock 1			
TRACK	BEAT/MEASURE	START TIME	TEMPO	MEMORY	
0	4/4	00 1:01	096	01-1	

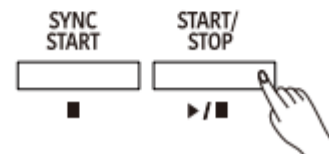

Playing entire songs in a style

In this mode, the piano also plays the appropriate chords when chord mode is activated.

In chord mode, the piano offers the following options:

Chord type	Description
Fingered	Automatically recognizes all types of chords
Multi Finger	Only recognizes multi-finger chords (C major 6, for example)
Bass inversion	Plays the inverted bass version of the chord being played
Full Range	Combines all of the above functions

1. Press the A.B.C. button and select the desired mode by pressing it again.

If you only want to play certain chords, press and hold A.B.C. to access the settings and select the chord type using +/-.

2. Press SYNC START. This will start the automatic accompaniment after you have played a chord.

Alternatively, you can also play a song in the background by pressing START/STOP.

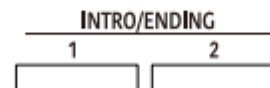
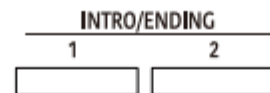
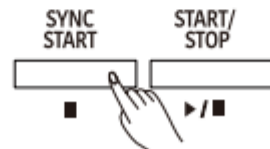
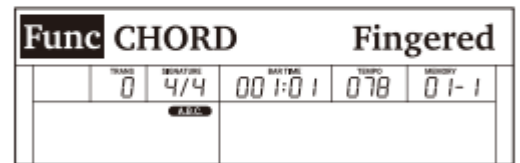
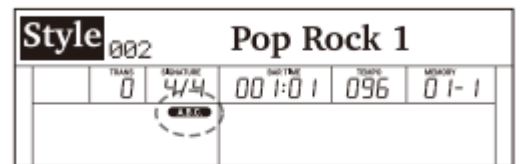
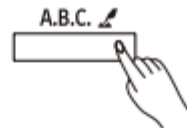

Accompaniment variations

Other effects can also be added to increase the variation.

INTRO

Adds a suitable intro.

MAIN

This adds a suitable chord pattern.

FILL IN

This adds a suitable sequence of chords.

END

This adds a suitable ending. Once the ending is finished, the automatic accompaniment also stops.

Adjusting the speed

Each style comes with its own tempo, but you can change this as you wish.

1. Press TEMPO+ or TEMPO- to adjust the speed. You can also turn the DATA CONTROL WHEEL.
2. The default value can be restored by pressing + and – simultaneously.

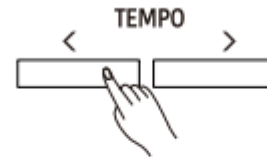

Style 002	Pop Rock 1				
TEMPO	BEAT/S	BAR TIME	TEMPO	MEMORY	
0	4/4	00 1:01	086	01-1	
▲▲▲					

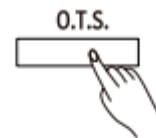

Style 002	Pop Rock 1				
TEMPO	BEAT/S	BAR TIME	TEMPO	O.T.S.	
0	4/4	00 1:01	086	1	
▲▲▲					

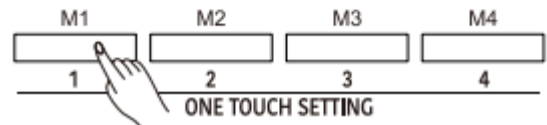

One-touch setting

This allows you to access all automatic accompaniment settings (including voice selection and digital effects).

1. Press O.T.S. to activate the function.
2. Press M1-M4 to call up the settings that match the current style.

Note: In the OTS menu, you can specify exactly which functions should be activated and which should not.

Metronome

The metronome provides a steady beat to help you play.

1. Press METRO.
2. Press METRO again to turn off the metronome.

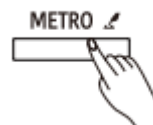

Metronome tempo and tone

Press and hold METRO to access the settings, then use +/- to change the tempo.

Func METRO	4/4				
TEMPO	BEAT/S	BAR TIME	TEMPO	MEMORY	
0	4/4	00 1:01	096	01-1	
▲▲▲					

Equalizer

Here you can adjust the volume of all effects and tracks to maintain balance.

1. Press MIXER.
2. Select the desired parameter.
3. Adjust the volume of the parameter using +/-.
The default value can be restored by pressing + and – simultaneously.



Mixer		MUSIC VOL:				20			
TRANS	0	SIGNATURE	4/4	BAR TIME	00 1:01	TEMPO	096	MEMORY	01-1

Parameter	LCD Display	Volume Range
Music volume	MUSIC VOL: xxx	0 - 32
Voice R1 volume	R1 VOL: xxx	0 - 32
Voice R2 volume	R2 VOL: xxx	0 - 32
Voice L volume	L VOL: xxx	0 - 32
Metronome volume	METRO VOL: xxx	0 - 32
Mic volume	MIC VOL: xxx	0 - 32
Rhythm sub. volume	RHYTHM_S VOL: xxx	0 - 32
Rhythm master volume	RHYTHM_M VOL: xxx	0 - 32
Bass volume	BASS VOL: xxx	0 - 32
Chord 1 volume	CHORD1 VOL: xxx	0 - 32
Chord 2 volume	CHORD2 VOL: xxx	0 - 32
Chord 3 volume	CHORD3 VOL: xxx	0 - 32
Phrase 1 volume	PHRASE1 VOL: xxx	0 - 32
Phrase 2 volume	PHRASE2 VOL: xxx	0 - 32

DSP effect

The DSP effect gives your sound a certain depth or its own ambience. This is achieved by simulating a real environment, such as playing in a large hall.

The DSP effect is enabled by default and can be disabled using the DSP button.

1. Press and hold the DSP button.
2. Select the desired parameter
3. Change the parameter with +/-.

Parameter	Display	Range
Voice R1 DSP Effect Type	R1 DSP TYPE xxx	Hall, Room, Crs.Dely, Tp.Delay, Tp.Echo, Chorus, Flanger, Phaser, Overdriv, Amp, Metl.Dst, Hard.Dst, Tremolo, Auto.Wah, Tp.Wah, None(Off)
Voice R1 DSP Effect Level	R1 DSP LEVEL xxx	0-32
Voice R1 Global Reverb Level Send	R1 G.REV SEND xxx	0-32
Voice R1 Global Chorus Level Send	R1 G.CHR SEND xxx	0-32
Voice R2 DSP Effect Type	R2 DSP TYPE xxx	Hall, Room, Crs.Dely, Tp.Delay, Tp.Echo, Chorus, Flanger, Phaser, Overdriv, Amp, Metl.Dst, Hard.Dst, Tremolo, Auto.Wah, Tp.Wah, None(Off)
Voice R2 DSP Effect Level	R2 DSP LEVEL xxx	0-32
Voice R2 Global Reverb Level Send	R2 G.REV SEND xxx	0-32
Voice R2 Global Chorus Level Send	R2 G.CHR SEND xxx	0-32
Voice L DSP Effect Type	L DSP TYPE xxx	Hall, Room, Crs.Dely, Tp.Delay, Tp.Echo, Chorus, Flanger, Phaser, Overdriv, Amp, Metl.Dst, Hard.Dst, Tremolo, Auto.Wah, Tp.Wah, None(Off)
Voice L DSP Effect Level	L DSP LEVEL xxx	0-32
Voice L Global Reverb Level Send	L G.REV SEND xxx	0-32
Voice L Global Chorus Level Send	L G.CHR SEND xxx	0-32
Microphone DSP Effect Type	MIC DSP TYPE xxx	Echo1, Echo2, Echo3, Phaser1, Phaser2, Enhanc, Wah, Overdv1, Overdv2, Lo-Fi, Comp, Gate, None(Off)
Microphone DSP Effect Level	MIC DSP LEVEL xxx	0-32
Microphone Global Reverb Level Send	MIC G.REV SEND xxx	0-32
Microphone Global Chorus Level Send	MIC G.CHR SEND xxx	0-32
Global Reverb Type	G.REV TYPE xxx	Hall1, Hall2, Hall3, Hall4, Pno.Hall, Room1, Room2, Room3, Church, Garage, Std.Hall
Global Reverb Level	G.REV LEVEL xxx	0-32
Global Chorus Type	G.CHR TYPE xxx	Chorus1, Chorus2, Chorus3, Chorus4, GM.Chr1, GM.Chr2, Celeste1, Celeste2, Sympho1, Sympho2, Doubler, Std.Chr
Global Chorus Level	G.CHR LEVEL xxx	0-32

Harmony

This function allows you to add different harmony notes to the right-hand notes, immediately giving your playing a more harmonious sound.

Playing with the harmony function

1. Press HARMONY to activate the function; the indicator light will illuminate.
2. Turn on the A.B.C. function and play a chord with your left hand. When you play with your right hand, harmonies will be added automatically.
3. Press HARMONY again to turn off the function.



Setting the harmony variation

1. Press and hold the HARMONY button to open the corresponding menu.
2. Use the +/YES and -/NO buttons to select a harmony type.

Func	HARMONY				Duet
TRANS	SIGNATURE	BAR TIME	TEMPO	MEMORY	
0	4/4	00 1:0 1	096	0 1- 1	
[SELECT]					

Please note: Harmony types "1+5" and "Octave" are always available; the others are only available when you activate the A.B.C. function and play a chord in the left-hand area of the keyboard.

Function menu

1. Press the FUNCTION button to open the menu; the current parameter appears on the display.
2. Use the rotary wheel to select a parameter. Use the +/YES and -/NO buttons to change the values. Press both buttons simultaneously to reset the value to the factory setting.

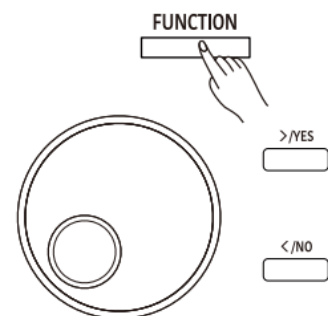

Please note: If no input is made within 10 seconds, the function menu will automatically close.

Voice settings

This function changes the tuning of the entire keyboard in 2-cent steps within a range of ± 50 cents (100 cents).

1. Select the "Tune" parameter in the function menu.
2. Use the +/YES and -/NO buttons to change the value.

Func	TUNE					00
	TRANS	SIGNATURE	BAR TIME	TEMPO	MEMORY	
	0	4/4	00 1:0 1	096	0 1- 1	
A.B.C						

Octave shift

This function allows you to change the pitch of a selected sound by one octave.

1. Select the parameter "Octave R1", "Octave R2" or "Octave L" from the function menu.
2. Use the +/YES and -/NO buttons to change the value.

Func	OCTAVE R1					00
	TRANS	SIGNATURE	BAR TIME	TEMPO	MEMORY	
	0	4/4	00 1:0 1	096	0 1- 1	
A.B.C						

Please note: The factory settings for the sounds may vary.

Touch sensitivity

This function allows you to control the sound level via the touch sensitivity, just like on an acoustic instrument.

1. Select the "Touch" parameter in the function menu.
2. Use the +/YES and -/NO buttons to change the value.

Func	TOUCH					Medium1
	TRANS	SIGNATURE	BAR TIME	TEMPO	MEMORY	
	0	4/4	00 1:0 1	096	0 1- 1	
A.B.C						

Please note: The setting remains stored even when you switch off the instrument.

Chord type setting

Here you can set the chord input variant.

1. Select the "Chord" parameter in the function menu.
2. Use the +/YES and -/NO buttons to change the value.

Func	CHORD					Fingered
	TRANS	SIGNATURE	BAR TIME	TEMPO	MEMORY	
	0	4/4	00 1:0 1	096	0 1- 1	
A.B.C						

Changing the split point

The split point "divides" the keyboard into two areas. When automatic accompaniment (A.B.C) is active, the left hand controls the playback of the automatic accompaniment. When automatic accompaniment is inactive, the left hand plays the lower voice.

1. Select the parameter "Lower Split" in the function menu.
2. Use the +/YES and -/NO buttons to change the value.

Func	LOWER SPLIT					F#3
	TRANS	SIGNATURE	BAR TIME	TEMPO	MEMORY	
	0	4/4	00 1:0 1	096	0 1- 1	
A.B.C						

Twinova Split Point / Octave Shift

Here you can set the split point and octave for Twinova mode.

1. Select the "Twinova Split/Twinova Octave" parameter from the function menu.
2. Use the +/YES and -/NO buttons to change the value.

Func	TWINOVA SPLIT					E3
	TRANS	SIGNATURE	SAR TIME	TEMPO	MEMORY	
	0	4/4	00 1:0 1	078	0 1- 1	

Func	TWINOVA OCTAVE					0
	TRANS	SIGNATURE	SAR TIME	TEMPO	MEMORY	
	0	4/4	00 1:0 1	078	0 1- 1	

Harmony variant

1. Select the "Harmony" parameter from the function menu.
2. Use the +/YES and -/NO buttons to make your selection.

Func	HARMONY					Duet
	TRANS	SIGNATURE	SAR TIME	TEMPO	MEMORY	
	0	4/4	00 1:0 1	096	0 1- 1	

Harmony Type	LCD Display
Duet	Duet
Trio	Trio
Octave	Octave
1+5	1+5
Country Duet	CountryDuet
Block	Block
4 Close 1	4Close1
4 Close 2	4Close2
4 Open	4Open

Equalizer

The EQ controls the gain of the different frequency ranges. Different EQ values result in different sounds.

1. Select the "EQ" parameter from the function menu.
2. Use the +/YES and -/NO buttons to make your selection.

Func	EQ					Piano
	TRANS	SIGNATURE	SAR TIME	TEMPO	MEMORY	
	0	4/4	00 1:0 1	096	0 1- 1	

String resonance

When a piano sound is selected, pressing the sustain pedal produces a string resonance effect. The effect sounds like an acoustic grand piano.

1. Select the parameter "String Res."
 2. Use the +/YES and -/NO buttons to make your selection.
- Please note:** The setting will remain even if you turn off the piano.

Func	STRING RES.					8
	TRANS	SIGNATURE	SAR TIME	TEMPO	MEMORY	
	0	4/4	00 1:0 1	096	0 1- 1	

Soft Pedal

You can assign different functions to the soft pedal.

1. Select the "Soft Pedal" parameter in the function menu.
2. Use the +/YES and -/NO buttons to make your selection.

Detailed description of the pedal functions	
Function	Description
Soft	Produces a softer sound for the notes played
Play	Starts or stops playback of a style
Memory	Switches between memory locations

Freeze

When the Freeze function is activated, style settings are not changed even when a memory is recalled.

1. Select the "Freeze" parameter in the function menu.
2. Use the +/YES and -/NO buttons to make your selection.

Please note: The settings are only available when the Freeze function is active.

Func	FREEZE					Style
	0	4/4	00:1:01	096	01-1	

Metronome beat and tone

1. Select the "Metro" parameter from the function menu.
2. Use the +/YES and -/NO buttons to make your selection.

Func	METRO					4/4
	0	4/4	00:1:01	096	01-1	

Fade setting

You can set the time for the fade in/out in seconds.

1. Select the parameter "Fade Time" from the function menu.
2. Use the +/YES and -/NO buttons to make your selection.

Func	FADE TIME					10
	0	4/4	00:1:01	096	01-1	

MIDI Out Channel

Here you can set the MIDI Out channel for sound R1.

1. Select the "MIDI OUT CH" parameter from the function menu.
2. Use the +/YES and -/NO buttons to make your selection.

Func	MIDI OUT CH				01				
TRANS	0	SIGNATURE	4/4	BAR TIME	00 1:0 1	TEMPO	096	MEMORY	0 1- 1

Please note: The setting will remain even if you turn off the device.

Song Loop (continuous loop)

A loop is the continuous repetition of a playback. You can choose whether all songs should be repeated, only one song, or none at all.

1. Select the "Song Loop" parameter in the function menu.
2. Use the +/YES and -/NO buttons to make your selection.
make your selection

Func	SONG LOOP				All				
TRANS	0	SIGNATURE	4/4	BAR TIME	00 1:0 1	TEMPO	096	MEMORY	0 1- 1

Please note: This setting is retained even when the device is switched off.

Auto Standby (APO)

The device switches off automatically after 15 minutes of inactivity. You can deactivate this switch-off function or adjust the time to suit your requirements.

1. Select the "Power Off" parameter in the function menu.
2. Use the +/YES and -/NO buttons to make your selection.

Func	POWER OFF				15 min				
TRANS	0	SIGNATURE	4/4	BAR TIME	00 1:0 1	TEMPO	096	MEMORY	0 1- 1

Please note: This setting is saved even when you switch off the instrument. Only deactivate the APO function for stage use.

System time settings

It may be useful to have an accurate time setting, as this is used for saving data, for example. The setting is retained even when you switch off the device.

1. Select the "Year / Month / Day / Hour / Minute" parameter in the function menu.
2. Use the +/YES and -/NO buttons to set the time.

Func	YEAR				2016				
TRANS	0	SIGNATURE	4/4	BAR TIME	00 1:0 1	TEMPO	096	MEMORY	0 1- 1

Automatic Bluetooth connection

This setting determines whether Bluetooth connections are established automatically or not. Once a Bluetooth device has been successfully paired, the piano can automatically establish a connection as soon as the device comes within range.

1. In the function menu, select the parameter "Bluetooth Auto" from the function menu.
2. Use the +/YES and -/NO buttons to make your selection.

Func						BLUETOOTH AUTO On					
	TRK	REPEAT	REPEAT	REPEAT	REPEAT						
	0	4/4	00:01	096	01-1						

Resetting to factory settings

1. Select the "System Reset" parameter from the function menu.
2. Press +/YES; "Reset all settings?" appears on the display.
3. Press +/YES if you really want to discard all your settings.
4. The next question "Delete the user song?" appears on the display.
5. If you want to delete all your songs, confirm the question with +/YES.
6. The process may take some time. Please wait patiently!

Func						SYSTEM RESET					
	TRK	REPEAT	REPEAT	REPEAT	REPEAT						
	0	4/4	00:01	096	01-1						

Please note: Do not switch off the device during this process, as this may destroy the internal data of the instrument and lead to malfunctions.

Performance Memory

The "Performance Memory" function allows you to save all your settings and recall them at the touch of a button.

Please note: To reset the memory to the factory settings, hold down the factory settings, hold down the STORE and M1 buttons pressed while turning on the device. This will delete all memory locations.

Setting the panel

1. There are 6 memory locations (memory banks), M1-M6.
2. Hold down the STORE button and press one of the M1 to M6 memory buttons. Please note that this will overwrite the previous settings.



Voice						Grand Piano 1					
	TRK	REPEAT	REPEAT	REPEAT	REPEAT						
	0	4/4	00:01	096	01-1						

Recalling settings

Press one of the memory buttons M1 to M6; your settings will be recalled immediately.

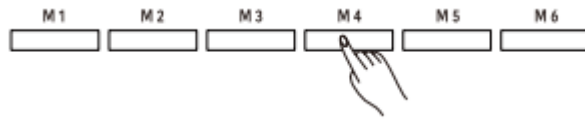

If the "O.T.S" function is active, no information can be recalled from memory.

Selecting a memory bank

1. Press BANK; the current number appears in the display.
2. Select a memory location by pressing the BANK button repeatedly.

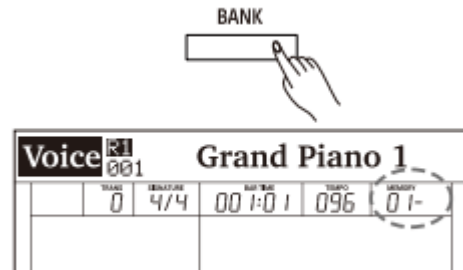

Making certain settings unchangeable (freeze function)

When the freeze function is activated, some style settings cannot be changed even when a memory is recalled.

1. Press FREEZE to activate the function. The indicator light will illuminate.
2. Press FREEZE again to turn it off; the indicator light will go out.
3. Press and hold the FREEZE button to enter the corresponding settings menu. You can specify whether the settings for voice, style, or song settings should be "frozen."



Recording a song

You can choose between audio and MIDI recordings.

MIDI recording

You can save a MIDI recording as a user song in your piano. You can play it back there or save it to a USB flash drive.

Preparing to record

Press REC to put the device into standby mode. The indicator light will illuminate and "Rec" will flash on the display.

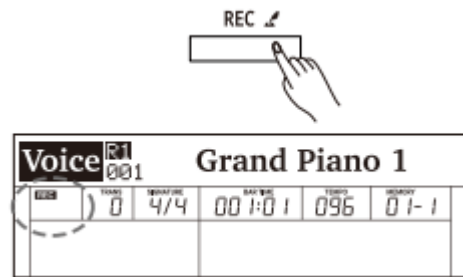

Please note: If a flash drive is inserted, press and hold the REC button to open the settings menu and select "MIDI" as the recording mode. You can also choose whether you want to save the recording to the piano or to the flash drive. Once you have finished the settings, press REC to put the device into standby mode.

In standby mode, you can select the settings for sound, style, tempo, etc.

To exit standby mode, press REC.

Starting recording

From Standby mode, you can start recording by pressing START/STOP or by starting to play. The indicator light on the REC button lights up and the display stops flashing.

Stop recording

1. To stop recording, press REC; the indicator light will go out.
2. When the memory is full, recording stops automatically and the recording is saved.

Playing back a recording

1. After stopping recording by pressing the REC button, song mode is activated and the recorded song is displayed. Press START/STOP to start playback.

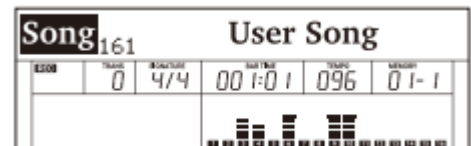

2. In standby mode, you can press SONG to enter this mode. Use the +/YES and -/NO buttons to select a user song and then press START/STOP to play the song.

Recording settings

1. Press and hold the REC button to open the settings menu.
2. Select a parameter using the rotary wheel.
3. Change the settings using the +/YES and -/NO buttons.
4. You can then start recording as described.

Rec		Record Type:				MIDI
MODE	0	4/4	00 1:0 1	096	01-1	

Parameter	LCD Display	Range
Record Type Setting	Record Type: xxx	MIDI, MP3
MIDI Recording Channel 1	Ch1:R1 xxx	On, Off
MIDI Recording Channel 2	Ch2:R2 xxx	On, Off
MIDI Recording Channel 3	Ch3:L xxx	On, Off
MIDI Recording Channel 4	Ch4:MIDI Ch4 xxx	On, Off
MIDI Recording Channel 5	Ch5:MIDICh5 xxx	On, Off
MIDI Recording Channel 6	Ch6:MIDICh6 xxx	On, Off
MIDI Recording Channel 7	Ch7:MIDICh7 xxx	On, Off
MIDI Recording Channel 8	Ch8:MIDICh8 xxx	On, Off
MIDI Recording Channel 9	Ch9:Rhythm_s xxx	On, Off
MIDI Recording Channel 10	Ch10:Rhythm_m xxx	On, Off
MIDI Recording Channel 11	Ch11:Bass xxx	On, Off
MIDI Recording Channel 12	Ch12:Chord1 xxx	On, Off
MIDI Recording Channel 13	Ch13:Chord2 xxx	On, Off
MIDI Recording Channel 14	Ch14:Chord3 xxx	On, Off
MIDI Recording Channel 15	Ch15:Phrase1 xxx	On, Off
MIDI Recording Channel 16	Ch16:Phrase2 xxx	On, Off
Saving the MIDI Recording To	MIDI Save To: xxx	Internal Flash, USB Flash

Please note:

1. The settings for the first and last parameters can only be changed when a flash drive is inserted. For more information, refer to the section entitled "Flash Drive."
2. If you used DSP effects during MIDI recording, the preset DSP effects for sounds R1, R2, and L will be deactivated during MIDI playback and cannot be changed. They will be reactivated as soon as you pause or stop MIDI playback or exit MIDI mode.
3. If you are using channels 4-8 for recording, please connect an external MIDI keyboard or similar MIDI device via the MIDI or USB port and adjust the MIDI Out channels accordingly.

Audio recordings

When you make an audio recording, the recording is saved as an MP3 file on a USB flash drive. All sounds you hear during recording are saved faithfully.

1. Connect a USB flash drive and wait until the indicator light comes on.
2. Press REC to start recording; the indicator light will illuminate. If you want to make a MIDI recording instead, hold down the REC button and change the recording type to MIDI in the settings as described above.
3. During recording, you can use the automatic accompaniment, the keyboard, play songs or demos, play music via the Aux In jack or via a microphone. All these sounds will be recorded.
4. To stop recording, press the REC button. The indicator light goes out.
5. The recorded song is automatically saved as "AudioRec 001."
Press START/STOP to start playback.

Please note: Never remove the USB drive or turn it off while a song is being saved. This could damage both the file and the drive.

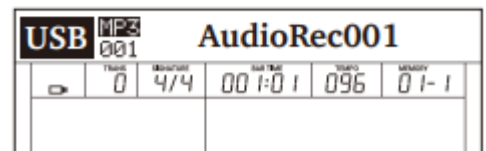
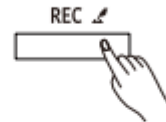
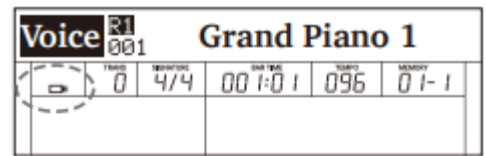

Preset songs

The piano has a selection of beautiful piano pieces, which you will find in the song overview in the appendix.

Playing songs

1. Press SONG to enter the mode; the number and name of the current song appear on the display.
2. Select a song using the dial wheel or the +/YES and -/NO buttons.
3. Press START/STOP to start playback.

Please note:

1. You can use the loop function to play songs continuously.
2. When Bluetooth is active, press the SONG button once to activate Bluetooth mode and a second time to switch to song mode.

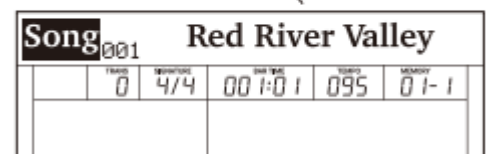

Song playback settings

1. Press button (15) to fast forward a song, (14) to rewind it, and 16 to pause it.
2. Pressing button (12) will repeat the current song continuously; press 13 to repeat all songs continuously.



Practicing songs

The melody track can be turned off for all songs.

1. Press the LEFT button to turn off the melody for the left hand; the "L-Off" indicator will light up. You can now practice the part for the left hand.
2. You can practice the part for the right hand in the same way: press RIGHT; the "R-Off" light will light up.



Song		L-OFF		Red River Valley		
001		TRACK	MEASURE	BAR TIME	TEMPO	MEMORY
		0	4/4	00 1:01	095	01-1

Song		R-OFF		Red River Valley		
001		TRACK	MEASURE	BAR TIME	TEMPO	MEMORY
		0	4/4	00 1:01	095	01-1

Bluetooth

1. The Bluetooth function is enabled by default; the Bluetooth name is "PIANO-AUDIO."
2. You can pair the piano with another Bluetooth device; once pairing is successful, this information is saved and the connection is always established automatically when the device is within range. You can disable this function in the function menu.

Playing Bluetooth songs

1. Once pairing is complete, the indicator will appear on the display. Press the SONG button (25) to activate Bluetooth mode.
2. Press START/STOP to start playback.
3. You can select a Bluetooth song using buttons (14) and (15). You can also use the +/YES and -/NO buttons.



Song		Buletooth Music				
0		TRACK	MEASURE	BAR TIME	TEMPO	MEMORY
		0	4/4	00 1:01	095	01-1

Ending the Bluetooth connection

1. Use the rotary knob to select "Disconnect" and then press +/YES. The display shows "Disconnect Bluetooth?" appears on the display.
2. Press +/YES to disconnect.

Song		Disconnect				
TRACK	REPEAT	TIME	TRAC	REPEAT		
0	4/4	00:01	095	01-1		

Please note: In Bluetooth mode, you can press SONG to switch to song mode.

Connecting a USB flash drive

The instrument recognizes USB flash drives between 32 MB and 128 GB that are formatted in FAT32 and are not partitioned. We recommend formatting the flash drive before using it in the instrument.

A flash drive in FAT 32 format supports up to 512 files in its root directory. Anything beyond that cannot be saved.

Playing files from a USB stick

1. Press USB to open the menu. All MIDI and MP3 songs in the root directory of the USB stick appear on the display.
2. Use +/YES and -/NO to select a song.
3. Press START/STOP to start playback. You can also activate a loop; see the "Function menu" chapter.
4. Press START/STOP again to stop playback.



USB		AudioRec001				
TRACK	REPEAT	TIME	TRAC	REPEAT		
0	4/4	00:01	096	01-1		

Saving files to a USB stick

1. Press and hold the USB button to open the menu and select "Save MIDI" with the dial wheel.
2. Press +/YES to save the song in the root directory of the flash

USBMenu		Save MIDI				
TRACK	REPEAT	TIME	TRAC	REPEAT		
0	4/4	00:01	096	01-1		

The name of the song is

"UserSong00X_YYMMDD_NUB.MIDI." If the user song does not contain any data, the device displays "NoFile!"

3. After successful storage, the device displays "User song save successful!" and returns to the USB menu.

Composition of the song name:

"UserSong00X" is the name and number of the user song, "YYMMDD" is the year, month, and date of recording, and "NUB" is the sequential number (001-512).

Loading a file from USB

1. Press and hold the USB button and select "Load MIDI" with the rotary wheel.
2. Press +/YES; the display shows all MIDI files (*.mid) in the root directory. Use the rotary wheel to select one.
3. Press +/YES; "Load MIDI successful!" appears on the display to indicate that the song has been loaded successfully.
loading process. If the user song in the instrument is not empty, the display will ask "Overwrite the User Song?". If you want the song to be overwritten, press +/YES. If you do not want this, press -/NO.
4. After the loading process, the display returns to the USB menu.

USBMenu		Load MIDI			
TRK	BEATS	TIME	TEMPO	SECT	
0	4/4	001:01	096	01-1	

Please note that overwriting will delete the original song on the instrument!

Formatting the USB stick

1. Press and hold the USB button to open the menu. Use the dial wheel to select "Format USB."
2. Press +/YES; "Format USB Flash Drive?" appears on the display.
3. Press +/YES to format the drive or -/NO to cancel the process.
4. After formatting, the device returns to the USB menu.

USBMenu		Format USB			
TRK	BEATS	TIME	TEMPO	SECT	
0	4/4	001:01	096	01-1	

MIDI

What is MIDI?

MIDI (Musical Instrument Digital Interface) is a worldwide standard for communication between electronic musical instruments and computers. By exchanging information between devices, MIDI instrument and drive systems can be created that are more versatile and flexible than isolated instruments. You can connect computers, sequencers, expanders, or other keyboards to your keyboard. MIDI signals can be divided into two groups: channel signals and system signals. The Pino has a USB port that can be used for both MIDI In and MIDI Out.

Troubleshooting

Problem	Possible cause and solution
<p>You hear a "pop" when the device is turned on or off.</p> <p>Noises occur during use of a mobile phone.</p>	<p>This is normal and not a cause for concern.</p> <p>A mobile phone near the instrument may cause interference. Turn off the phone or move further away from the device.</p>
Problem	Possible cause and solution
<p>You cannot hear anything when playing the keyboard.</p>	<p>The volume may be set too low. Turn it up a little. Check whether headphones are connected. Check whether the volume for R1/R2/L is set too low on the mixer.</p>
<p>The automatic accompaniment does not start even though it is in standby mode.</p>	<p>Try starting the automatic accompaniment in the right-hand range. To start it synchronously, you must press a key in the left-hand range.</p>
<p>Certain notes sound wrong.</p>	<p>Check that the tune value is set to 0. You can reset the instrument to the factory settings by holding down the +/YES and /NO buttons while turning on the keyboard.</p>
<p>The keyboard is not recognized after connecting to a computer.</p>	<p>Check that the USB cable is properly connected and, if necessary, try connecting the keyboard to a different USB port.</p>
<p>The pedal does not work.</p>	<p>Check that it is connected correctly.</p>
<p>Reading/writing to a USB flash drive does not work.</p>	<p>Only unpartitioned flash drives in FAT32 format are recognized. Please format the flash drive before use.</p>
<p>The device switches off after a while.</p>	<p>The device switches off automatically after a certain period of time. You can deactivate this function in the function menu.</p>

Specifications

Keyboard & Display	
Keyboard	88 Graded Hammer-Action Keys with Triple Sensors
Touch Response	6 types, Off
Display	Multi-functional LCD
Voices	
Polyphony (max.)	256
Voices	1200 panel, 13 drum kits
Layer	Left, Right1, Right2
Split	Yes
Duo (Twinova)	Yes
Styles	
Styles	270 presets
Style Control	Start / Stop Sync start Sync stop Intro 1 / Ending 1 Intro 2 / Ending 2 Main A / Fill in A Main B / Fill in B Main C / Fill in C Main D / Fill in D A.B.C. Fade in/out
Style Creator	—
O.T.S.	Yes
Chord Types	32
Effects	
Effects	DSP on / off; Second-generation Acoustic Piano String Resonance Simulation
Master EQ	6 types
Reverb	11 types
Chorus	12 types
Voice Effect	15 types
Performance Enhance	
Harmony	9 types
Song & Recording	
Music Library	90 preset songs; L / R hand learning
Sequencer	1 user song (16 tracks)
Demo Song	3
Audio Playback	MP3
Audio Recorder	MP3
Score Display	—
Pitch Adjustment	
Transpose	-12 ~ +12
Octave	-2 ~ +2
Tuning	-50 ~ +50
Other Functions	
Mixer	Yes (14 tracks)
Performance Memory	32 preset banks x 6
Assignable Controllers	Soft pedal
Pitch Bend	—
Modulation	—
Metronome	Yes
Tempo	30 ~ 280
Other control	Piano mode; Brilliance; Bluetooth Audio/MIDI

Connections	
Interaction & Expansion	USB MIDI, USB Audio, Bluetooth
External Drive	USB flash drive (128G max)
Microphone	YES (Mic effect:12 types)
Phones	2 Standard Stereo
Pedals	Sustain, Soft, Sostenuto
MIDI	In, Out, Thru
USB	USB Audio & MIDI
Input	2 Standard mono
Output	2 Standard mono
Power Supply	
Power	AC 220V
Power Off Protection	Yes
Amplifiers & Speakers	
Amplifiers	100W x 2
Speakers	40W x 2, 20W x 2
Dimensions & Weight	
Dimensions LWH (mm)	1476 x 947 x 932
Weight (kg)	101

Appendix Voice list

No.	Voice Name	LCD Name
Piano		
1	Acoustic Grand Piano 1	Grand Piano 1
2	Acoustic Grand Piano 2	Grand Piano 2
3	Bright Acoustic Piano (wide) 1	Bright Pno/Wide 1
4	Acoustic Grand Piano (dark) 1	Grand Piano/Dark 1
5	Rock Piano	Rock Piano
6	Honky Tonk Piano (wide) 1	Honky Tonk/Wide 1
7	Octave Grand Piano 1	Octave Piano 1
8	Octave Grand Piano 2	Octave Piano 2
9	Grand Piano/Live	Grand Piano/Live
10	Bright Acoustic Piano 1	Bright Piano 1
11	Grand Piano (Warm)	Grand Piano/Warm
12	Octave Grand Piano 3	Octave Piano 3
13	Octave Grand Piano 4	Octave Piano 4
14	Honky Tonk Piano 1	Honky Tonk 1
15	Harpsichord (Live)	Harpsichord/Live
16	Harpsichord (Octave) 1	Harpsi/Octave 1
17	Harpsichord 1	Harpsichord 1
18	Electric Grand Piano 1	Electric Grand 1
19	Electric Grand Piano 2	Electric Grand 2
20	Pop Piano	Pop Piano
21	Piano & Strings 1	Piano&Strings 1
22	Piano & Pad 1	Piano&Pad 1
23	Piano & Choir 1	Piano&Choir 1
24	Piano & EP 1	Piano&EP 1
25	Piano & EP 2	Piano&EP 2
26	Electric Grand Piano 3	Electric Grand 3
27	Harpsichord (Octave) 2	Harpsi/Octave 2
28	Harpsichord & Strings	Harpsi&Strings
29	Electric Grand Piano 4	Electric Grand 4
Electric Piano		
30	Electric Piano 1	E.Piano 1
31	Electric Piano 2	E.Piano 2
32	Modern Electric Piano 1	Modern EP 1
33	Jazz Electric Piano 1	Jazz EP 1
34	Modern Electric Piano 2	Modern EP 2
35	Jazz Electric Piano 2	Jazz EP 2
36	Phase Electric Piano 1	Phase EP 1
37	Vintage Electric Piano 1	Vintage EP 1
38	Funk EP 1	Funk EP 1
39	Vintage Electric Piano 2	Vintage EP 2
40	Classic Electric Piano 1	Classic EP 1
41	Electric Piano 3	E.Piano 3
42	Tremolo EP 1	Tremolo EP 1
43	Funk EP 2	Funk EP 2
44	60's Electric Piano 1	60's EP 1
45	Vintage Electric Piano 3	Vintage EP 3
46	Warm Electric Piano	Warm EP
47	Tremolo EP 3	Tremolo EP 3
48	Electric Piano 4	E.Piano 4
49	Modern Electric Piano 3	Modern EP 3
50	Tremolo EP 2	Tremolo EP 2
51	Classic Electric Piano 2	Classic EP 2
52	Sereo Clavi	Sereo Clavi
53	Phase Clavi	Phase Clavi

54	Clavi 1	Clavi 1
55	Wah Clavi 1	Wah Clavi 1
56	Clavi 2	Clavi 2
57	Wah Clavi 2	Wah Clavi 2
58	Massiness Electric Piano	Massiness EP
59	Wah Electric Piano	Wah EP
60	Bright Electric Piano	Bright EP
61	Dark Electric Piano	Dark EP
62	Wire Electric Piano	Wire EP
63	Aah Electric Piano	Aah EP
64	Overdriven Electric Piano	Overdriven EP
65	Modern Jazz Electric Piano	Modern Jazz EP
66	Jump Electric Piano	Jump EP
67	Warm Jump Electric Piano	Warm Jump EP
68	Metallic Electric Piano 1	Metallic EP 1
69	Metallic Electric Piano 2	Metallic EP 2
70	Rock Electric Piano	Rock EP
71	Pop Electric Piano	Pop EP
72	Crysta Electric Piano	Crysta EP
73	Crysta Jazz Electric Piano	Crysta Jazz EP
74	Rock Electric Clavi	Rock Elec Clavi
75	Jazz Electric Clavi	Jazz Elec Clavi
76	Pop Electric Clavi	Pop Elec Clavi
77	Aahs Electric Clavi	Aahs Elec Clavi
78	Bright Electric Clavi	Bright Elec Clavi
79	Warm Electric Clavi	Warm Elec Clavi
80	Echo Electric Clavi	Echo Elec Clavi
81	Dark Electric Clavi	Dark Elec Clavi
Organ		
82	Drawbar Organ 1	Draw Org 1
83	Percussive Organ 1	Perc Org 1
84	Rock Organ 1	Rock Org 1
85	Church Organ 1	Church Org 1
86	Detuned Church Organ 1	Det Church Org 1
87	Percussive Organ 2	Perc Org 2
88	Detuned Percussive Organ 1	Det Prec Org 1
89	Rotary Organ 1	Rotary Org 1
90	Church Organ (octave mix) 1	ChurchOrg/Octave 1
91	Rock Organ 2	Rock Org 2
92	Detuned Organ	Detuned Org
93	Rotary Organ 2	Rotary Org 2
94	Pop Organ	Pop Org
95	Classic Organ 1	Classic Org 1
96	Jazz Organ 1	Jazz Org 1
97	Rock Organ 3	Rock Org 3
98	Rotary Organ 3	Rotary Org 3
99	Classic Organ 2	Classic Org 2
100	Detuned Drawbar Organ	Detuned DrawOrg
101	Italian 60's Organ 1	60's Org 1
102	Rock Organ 4	Rock Org 4
103	Percussive Organ 3	Perc Org 3
104	Drawbar Organ 2	Drawbar Org 2
105	Classic Organ 3	Classic Org 3
106	Italian 60's Organ 2	60's Org 2
107	Drawbar Organ 3	Drawbar Org 3
108	Vintage Organ 1	Vintage Org 1

109	Vintage Organ 2	Vintage Org 2
110	Detuned Church Organ 2	Det Church Org 2
111	Mellow Organ 1	Mellow Org 1
112	Mellow Organ 2	Mellow Org 2
113	Mellow Organ 3	Mellow Org 3
114	Mellow Organ 4	Mellow Org 4
115	Organ 1	Organ 1
116	Organ 2	Organ 2
117	Organ 3	Organ 3
118	Reed Organ 1	Reed Org 1
119	Puff Organ 1	Puff Org 1
120	Dark Drawbar Organ	Dark Drawbar Organ
121	Soft Drawbar Organ	Soft Drawbar Org
122	Soft 60's Organ	Soft 60's Org
123	Bright 60's Organ	Bright 60's Org
124	Detuned Classic Organ	Det Classic Org
125	Mellow Rotary Organ	Mellow Rot Org
126	Dark Rotary Organ	Dark Rotary Org
127	Bright Rotary Organ	Bright Rot Org
128	Bright Percussive Organ	Br Perc Org
129	Jazz Percussive Organ	Jazz Perc Org
130	Rock Percussive Organ	Rock Perc Org
131	Octave Percussive Organ	Octave Perc Org
132	Mellow Percussive Organ	Mellow Perc Org
133	Puff Percussive Organ	Puff Perc Org
134	Pop Percussive Organ	Pop Perc Org
135	Reed Percussive Organ	Reed Perc Org
136	Vintage Rock Organ	Vintage Rock Org
137	Dark Rock Organ	Dark Rock Org
138	Mellow Rock Organ	Mellow Rock Org
139	Soft Rock Organ	Soft Rock Org
140	Reed Rock Organ	Reed Rock Org
141	Rotary Rock Organ	Rotary Rock Org
142	Wah Rock Organ	Wah Rock Org
143	Puff Rock Organ	Puff Rock Org
144	Bright Vintage Organ	Bright Vintage Org
145	Dark Vintage Organ	Dark Vintage Org
146	Mellow Vintage Organ	Mellow Vintage Org
147	Rotary Vintage Organ	Rotary Vintage Org
148	Rock Vintage Organ	Rock Vintage Org
149	Pop Vintage Organ	Pop Vintage Org
150	Soft Vintage Organ	Soft Vintage Org
151	Percussive Vintage Organ	Per Vintage Org
152	Dark Reed Organ	Dark Reed Org
153	Jazz Reed Organ	Jazz Reed Org
154	Pop Reed Organ	Pop Reed Org
155	Puff Reed Organ	Puff Reed Org
156	Rock Reed Organ	Rock Reed Org
157	Rotary Puff Organ	Rot Puff Org
158	Jazz Puff Organ	Jazz Puff Org
159	Pop Puff Organ	Pop Puff Org
160	Musette	Musette
161	Accordion 1	Accordion 1
162	Tango Accordion 1	Tango Accordion 1
163	Accord It Solo 1	Accord It Solo 1
164	Tango Accordion 2	Tango Accordion 2

165	Chorus Accordion	Chorus Accordion
166	Accordion 2	Accordion 2
167	Accord It Solo 2	Accord It Solo 2
168	Harmonica 1	Harmonica 1
169	Harmonica 2	Harmonica 2
170	Wah Harmonica	Wah Harmonica
171	Dark Musette	Dark Musette
172	Bright Musette	Bright Musette
173	Chorus Musette	Chorus Musette
174	Musette 2	Musette 2
175	Aah & Musette	Aah & Musette
176	Voice Oohs & Musette	Voice Ohs & Musette
177	Voice Oohs & Dark Musette	Ohs & Dk Muset
178	Dark Harmonica	Dark Harmonica
179	Bright Harmonica	Bright Harmonica
180	Chorus Harmonica	Chorus Harmonica
181	Harmonica 3	Harmonica 3
182	Aah & Harmonica	Aah & Harmonica
183	Voice Oohs & Harmonica	Voice Ohs & Harm
184	Voice Oohs & Dark Harmonica	Vc Ohs & Dk Harm
185	Dark Accordion	Dark Accordion
186	Bright Accordion	Bright Accordion
187	Chorus Accordion	Chorus Accordion
188	Aah & Accordion	Aah & Accordion
189	Voice Oohs & Accordion	Voice Oohs & Accd
190	Voice Oohs & Dark Accordion	Vc Ohs & Dk Accd
191	Accordion 3	Accordion 3
Guitar & Bass		
192	Nylon Guitar	Nylon Guitar
193	Steel Guitar 1	Steel Guitar 1
194	Jazz Guitar 1	Jazz Guitar 1
195	Clean Guitar 1	Clean Guitar 1
196	Steel Guitar 2	Steel Guitar 2
197	Mandolin	Mandolin
198	Funk Guitar 1	Funk Guitar 1
199	Velocity Clean Guitar	Velocity CleanGtr
200	Lead Guitar 1	Lead Guitar 1
201	Velocity Lead Guitar	Velocity LeadGtr
202	Lead Guitar 2	Lead Guitar 2
203	Overdriven Guitar 1	OverdrivenGtr 1
204	Tremolo clean Guitar	Tremolo cleanGtr
205	12-String Guitar	12String Guitar
206	Steel Guitar 3	Steel Guitar 3
207	Clean Guitar 2	Clean Guitar 2
208	Feedback Guitar 1	Feedback Guitar 1
209	5th Distortion	5th Distortion
210	Velocity Steel Guitar	Velocity SteelGtr
211	Delay Guitar 1	Delay Guitar 1
212	Vintage Guitar 1	Vintage Guitar 1
213	Jazz Guitar 2	Jazz Guitar 2
214	Rhythm Guitar	Rhythm Guitar
215	Jazz Lead 1	Jazz Lead 1
216	Vintage Guitar 2	Vintage Guitar 2
217	Classic Guitar	Classic Guitar
218	Jazz Lead 2	Jazz Lead 2
219	Vintage Guitar 3	Vintage Guitar 3

220	Folk Guitar	Folk Guitar
221	Chorus Guitar 1	Chorus Guitar 1
222	Muted Guitar 1	Muted Guitar 1
223	Pedal Guitar	Pedal Guitar
224	Distortion Guitar 1	DistortionGtr 1
225	Chorus Guitar 2	Chorus Guitar 2
226	Tremolo Guitar 1	TremoloGuitar 1
227	Octave Guitar	OctaveGuitar
228	Chorus Guitar 3	Chorus Guitar 3
229	Tremolo Guitar 2	TremoloGuitar 2
230	Metal Guitar	Metal Guitar
231	Clean Guitar 3	Clean Guitar 3
232	Wah Guitar	Wah Guitar
233	Jazz Guitar & EP	JazzGtr&EP
234	Distortion Guitar 2	DistortionGtr 2
235	12-String Electric Guitar	12StrE.Guitar
236	Feedback Guitar 2	Feedback Guitar 2
237	12-String Guitar 1	12String Guitar 1
238	Muted Guitar 2	Muted Guitar 2
239	Funk Guitar 2	Funk Guitar 2
240	Overdriven Guitar 2	OverdrivenGtr 2
241	12-String Guitar 2	12String Guitar 2
242	Nylon Guitar & Acoustic Bass	NyGt&AcBass
243	Steel Guitar & Finger Bass	StGt&FgBass
244	Chorus Steel Guitar	Chorus Ste Gt
245	Soft Chorus Steel Guitar	Soft Cho Ste Gt
246	Dark Chorus Steel Guitar	Dk Cho Ste Gt
247	Nylon Guitar & Steel Guitar	Ny Gt & Ste Gt
248	Jazz Guitar & Steel Guitar	Jazz Gt & Ste Gt
249	Distortion Steel Guitar	Dt Steel Guitar
250	Dark Steel Guitar	Dark Steel Gt
251	Warm Steel Guitar	Warm Steel Gt
252	Chorus Jazzy Guitar	Chorus Jazzy Gt
253	Bright Jazzy Guitar	Bright Jazzy Gt
254	Overdriven Jazzy Guitar	Over Jazzy Gt
255	Distortion Jazzy Guitar	Dist Jazzy Gt
256	Overdriven Octave Guitar	Over Octave Gt
257	Wah Octave Guitar	Wah Octave Gt
258	Jazz Octave Guitar	Jazz Octave Gt
259	Chorus Octave Guitar	Cho Octave Gt
260	Chorus Vintage Guitar	Cho Vintage Gt
261	Vintage Funk Guitar	Vintage Funk Gt
262	Overdriven Funk Guitar	Ovrdriv Funk Gt
263	Chorus Wah Guitar	Chorus Wah Gt
264	Clean Vintage Guitar	Clean Vintage Gt
265	Dark Vintage Guitar	Dark Vintage Gt
266	Bright Vintage Guitar	Brt Vintage Gt
267	Soft Vintage Guitar	Soft Vintage Gt
268	Dark Mute Guitar	Dark Mute Gt
269	Chorus Mute Guitar	Chorus Mute Gt
270	Overdrive Mute Guitar	Overdrive Mute Gt
271	Distortion Mute Guitar	Dist Mute Gt
272	Wah Mute Guitar	Wah Mute Gt
273	Pulse Mute Guitar	Pulse Mute Gt
274	Nylon Mute Guitar	Nylon Mute Gt
275	Funk Mute Guitar	Funk Mute Gt

276	Dark Overdrive Guitar	Dark Over Gt
277	Bright Overdrive Guitar	Bright Over Gt
278	Soft Overdrive Guitar	Soft Over Gt
279	Delay Overdrive Guitar	Delay Over Gt
280	Delay Feedback Guitar	Delay Feedback Gt
281	Chorus Feedback Guitar	Cho Feedback Gt
282	Wah Overdrive Guitar	Wah Over Gt
283	Dark Wah Overdrive Guitar	Dark Wah Over Gt
284	Chorus Distortion Guitar	Chorus Dist Gt
285	Dark Distortion Guitar	Dark Dist Gt
286	Wah Distortion Guitar	Wah Dist Gt
287	Velocity Lead Guitar 3	Velocity Lead Gt 3
288	Soft Distortion Guitar	Soft Dist Gt
289	Bright Lead Guitar 3	Bright Lead Gt 3
290	Modern Distortion Guitar	Modern Dist Gt
291	Delay Distortion Guitar	Delay Dist Gt
292	Finger Bass 1	Finger Bass 1
293	Acoustic Bass 1	Acoustic Bass 1
294	Pick Bass 1	Pick Bass 1
295	Fretless Bass 1	Fretless Bass 1
296	Slap Bass 1	Slap Bass 1
297	Resonant Bass	Resonant Bass
298	Attack Pulse	Attack Pulse
299	Resonant Bass 2	Resonant Bass 2
300	Analog Bass 1	Analog Bass 1
301	Resonance SynBass	Resonance SynBass
302	Rock Bass	Rock Bass
303	Fretless Bass 2	Fretless Bass 2
304	Pick Bass 2	Pick Bass 2
305	Finger Slap Bass	Finger Slap Bass
306	Acoustic Bass & Cymbal	Bass & Cymbal
307	Analog Bass 2	Analog Bass 2
308	Resonant Slap Bass	Resonant SlapBass
309	Warm Synth Bass 1	Warm Syn Bass 1
310	Hammer 1	Hammer 1
311	Synth Bass (rubber)	Synth Bass (rubber)
312	Power Slap Bass	Power Slap Bass
313	Finger Bass 2	Finger Bass 2
314	Warm Synth Bass 2	Warm Syn Bass 2
315	Mute Pick Bass	Mute Pick Bass
316	Attack Pulse 2	Attack Pulse 2
317	Bright Finger Bass	Brt Finger Bass
318	Overdriven Finger Bass	Over Finger Bass
319	Distortion Finger Bass	Dt Finger Bass
320	Distortion Guitar & Finger Bass	Dt Gt & Fngr Ba
321	Wah Finger Bass	Wah Finger Bass
322	Finger Slap Bass 2	Fngr Slap Bass 2
323	Soft Wah Slap Bass	Soft Wah Slap Ba
324	Dark Slap Bass	Dark Slap Bass
325	Bright Pick Bass	Bright Pick Bass
326	Dark Pick Bass	Dark Pick Bass
327	Overdriven Pick Bass	Over Pick Bass
328	Distortion Guitar&Pick Bass	DtGt&Pick Bass
329	Wah Pick Bass	Wah Pick Bass
330	Chorus Pick Bass	Cho Pick Bass
331	Warm Chorus Pick Bass	Warm Cho Pick Ba

332	Rock Bass 2	Rock Bass 2
333	Bright Fretless Bass	Brt Fret Bass
334	Overdriven Fretless Bass	Over Fret Bass
335	Distortion Fretless Bass	Dist Fret Bass
336	Wah Fretless Bass	Wah Fret Bass
337	Mute Fretless Bass	Mute Fret Bass
338	Dark Fretless Bass	Dark Fret Bass
339	Pick Mute Fretless Bass	Pick Mu Fret Bass
340	Slap Fretless Bass	Slap Fret Bass
341	Dark Slap Bass	Dark Slap Bass
342	Chorus Slap Bass	Chorus Slap Bass
343	Distortion Guitar & Slap Bass	DtGt & Slap Bass
344	Bright Resonant Slap Bass	Bt Rt Slap Bass
345	Dark Resonant Slap Bass	Dk Rt Slap Bass
346	Chorus Resonant Slap Bass	Chs Rt Slap Bass
347	Wah Resonant Slap Bass	Wah Rt Slap Bass
348	Warm Resonant Slap Bass	Warm Rt Slap Ba
349	Dark Power Slap Bass	Dk Power Slap Ba
350	Bright Power Slap Bass	Bt Power Slap Ba
351	Distortion Power Slap Bass	Dt Power Slap Ba
352	Distortion Guitar & Power Slap Bass	DtGt & PowrSlpBa
353	Overdriven Guitar & Power Slap Bass	OvGt & PowrSlpBa
354	Chorus Power Slap Bass	Cho Powr Slp Ba
355	Wah Power Slap Bass	Wah Powr Slp Ba
356	Warm Power Slap Bass	Warm Powr Slp Ba
357	Dark Analog Bass	Dark Analog Bass
358	Bright Analog Bass	Bt Analog Bass
359	Chorus Analog Bass	Cho Analog Bass
360	Wah Analog Bass	Wah Analog Bass
361	Distortion Guitar & Analog Bass	DtGt & Analog Ba
362	Overdriven Guitar & Analog Bass	OvGt & Analog Ba
363	Hammer Analog Bass	Hammer Analog Ba
364	Dark Hammer Bass	Dark Hammer Ba
365	Bright Attack Bass	Bright Attack Ba
366	Pulse Attack Bass	Pulse Attack Ba
367	Bright Pulse Bass	Bright Pulse Ba
368	Octave Analog Bass	Octave Analog Ba
369	Power Analog Bass	Power Analog Ba
370	Power Pulse Bass	Power Pulse Ba
371	Wah Pulse Bass	Wah Pulse Bass
372	Chorus Pulse Bass	Cho Pulse Bass
Strings		
373	Solo Strings	Solo Strings
374	Slow Strings 1	Slow Strings 1
375	Sweet Violin	Sweet Violin
376	Sweet Cello	Sweet Cello
377	The Strings 1	The Strings 1
378	Orchestra 1	Orchestra 1
379	Slow Strings 2	Slow Strings 2
380	Contrabass 1	Contrabass 1
381	Chamber Music	Chamber Music
382	Slow Strings 3	Slow Strings 3
383	Strings & Brass 1	Strings&Brass 1
384	Strings & Brass 2	Strings&Brass 2
385	Strings & Flute	Strings & Flute
386	Strings & Oboe	Strings & Oboe

387	Arco Strings 1	Arco Strings 1
388	String Ensembles 1	Str Ensembles 1
389	Choir Aahs 1	Choir Aahs 1
390	Voice Oohs	Voice Oohs
391	Synth Voice	Synth Voice
392	Orchestra 2	Orchestra 2
393	Arco Strings 2	Arco Strings 2
394	The Strings 2	The Strings 2
395	Tremolo Strings	Tremolo Strings
396	Pizzicato Strings	Pizzicato Str
397	The Strings 3	The Strings 3
398	Synth Strings 1	Synth Strings 1
399	Synth Strings 2	Synth Strings 2
400	Synth Strings 3	Synth Strings 3
401	Orchestral Harp	Orchestral Harp
402	Violin	Violin
403	Viola	Viola
404	Cello	Cello
405	Contrabass 2	Contrabass 2
406	Choir Aahs 2	Choir Aahs 2
407	Humming	Humming
408	Analog Voice	Analog Voice
409	Orchestra Hit	Orchestra Hit
410	Bass Hit Plus	Bass Hit Plus
411	6th Hit	6th Hit
412	Euro Hit	Euro Hit
413	Slow Sweet Violin	Slow Sweet Vin
414	Dark Sweet Violin	Dark Sweet Vin
415	Bright Sweet Violin	Bright Sweet Vin
416	Slow Violin	Slow Violin
417	Dark Violin	Dark Violin
418	Bright Violin	Bright Violin
419	Chorus Violin	Chorus Violin
420	Sweet Violin 2	Sweet Violin 2
421	Slow Viola	Slow Viola
422	Dark Viola	Dark Viola
423	Bright Viola	Bright Viola
424	Volin & Viola	Volin & Viola
425	Chorus Viola	Chorus Viola
426	Harp & Viola	Harp & Viola
427	Cello & Viola	Cello & Viola
428	Aah & Viola	Aah & Viola
429	Slow Cello	Slow Cello
430	Dark Cello	Dark Cello
431	Bright Cello	Bright Cello
432	Chorus Cello	Chorus Cello
433	Violin & Cello	Violin & Cello
434	Aah & Cello	Aah & Cello
435	Harp & Cello	Harp & Cello
436	Contrabass & Cello	Contrbs & Cello
437	Dark Contrabass	Dark Contrabass
438	Bright Contrabass	Bright Contrbs
439	Chorus Contrabass	Chorus Contrbs
440	Slow Contrabass	Slow Contrabass
441	Violin & Contrabass	Vin & Contrbs
442	Viola & Contrabass	Viola & Contrbs

443	Aah & Contrabass	Aah & Contrabass
444	Harp & Contrabass	Harp & Contrbs
445	Dark Tremolo Strings	Dark Trem Str
446	Bright Tremolo Strings	Brt Trem Str
447	Slow Tremolo Strings	Slow Trem Str
448	Cello & Tremolo Strings	Cello & Trem Str
449	Violin & Tremolo Strings	Violin & Trem Str
450	Aah & Tremolo Strings	Aah & Trem Str
451	Harp & Tremolo Strings	Harp & Trem Str
452	Chorus Tremolo Strings	Cho Trem Str
453	Dark Pizzicato Strings	Dark Pizz Str
454	Bright Pizzicato Strings	Bright Pizz Str
455	Bass Hit & Pizzicato Strings	BassH & Pizz Str
456	6th Hit & Pizzicato Strings	6th Hit&Pizz Str
457	Euro Hit & Pizzicato Strings	EuroHit & PizStr
458	Harp & Pizzicato Strings	Harp & PizzStr
459	Arco Strings & Pizzicato Strings	ArcoStr & PizzStr
460	Strings & Pizzicato Strings	St & Pizz Str
461	Dark Harp	Dark Harp
462	Bright Harp	Bright Harp
463	Aah Harp	Aah Harp
464	String Harp	String Harp
465	Chorus Harp	Chorus Harp
466	Humming & Harp	Humming & Harp
467	Euro Hit & Harp	Euro Hit & Harp
468	Synth Voice & Harp	Sy Voice & Harp
Brass & Sax		
469	Trumpet 1	Trumpet 1
470	Trombone 1	Trombone 1
471	Muted Trumpet 1	Muted Trumpet 1
472	French Horn 1	French Horn 1
473	Dark Trumpet Soft	DarkTrump Soft
474	Tuba	Tuba
475	Trumpet 2	Trumpet 2
476	Trombone 2	Trombone 2
477	Muted Trumpet 2	Muted Trumpet 2
478	Bright Trombone1	Bright Trombone1
479	Dark Trombone 1	Dark Trombone 1
480	Dark Trombone 2	Dark Trombone 2
481	Resonant Trombone 1	Reson Trb 1
482	Resonant Trombone 2	Reson Trb 2
483	Brassband 1	Brassband 1
484	French Horn 2	French Horn 2
485	Warm Trumpet	Warm Trumpet
486	Bright Trumpet	Bright Trumpet
487	Chorus Trumpet	Chorus Trumpet
488	Trumpet 1 & Trumpet 2	Trp 1 & Trp 2
489	Trombone & Trumpet	Tb & Trp
490	Tuba & Trumpet	Tuba & Trumpet
491	Resonant Trumpet	Reson Trp
492	French Horn & Trumpet	Fr Horn & Trp
493	Warm Trombone	Warm Trombone
494	Bright Trombone2	Bright Trombone2
495	Chorus Trombone	Chorus Trombone
496	Trombone1 & Trombone2	Trb1 & Trb2
497	French Horn & Trombone	Fr Horn & Trb

498	Tuba & Trombone	Tuba & Trombone
499	Soprano Sax & Trombone	Sp Sax & Trb
500	Alto Sax & Trombone	Alto Sax & Trb
501	Dark Tuba	Dark Tuba
502	Bright Tuba	Bright Tuba
503	Warm Tuba	Warm Tuba
504	Chorus Tuba	Chorus Tuba
505	Resonant Tuba	Resonant Tuba
506	Slow Tuba	Slow Tuba
507	Soprano Sax & Tuba	Sprno Sax & Tuba
508	Alto Sax & Tuba	Alto Sax & Tuba
509	Dark Muted Trumpet	Dark Muted Trp
510	Bright Muted Trumpet	Bright Muted Trp
511	Warm Muted Trumpet	Warm Muted Trp
512	Chorus Muted Trumpet	Chorus Muted Trp
513	Tuba & Muted Trumpet	Tuba & Muted Trp
514	French Horn & Muted Trumpet	FrHorn & MtTrp
515	Soprano Sax & Muted Trumpet	SprnSax & MtTrp
516	Alto Sax & Muted Trumpet	AltoSax & MtTrp
517	Dark French Horn	Dark French Horn
518	Bright French Horn	Bright Fr Horn
519	Warm French Horn	Warm French Horn
520	Chorus French Horn	Chorus Fr Horn
521	Tuba & French Horn	Tuba & Fr Horn
522	Soprano Sax & French Horn	SprnSax & FrHorn
523	Alto Sax & French Horn	AltoSax & FrHorn
524	Slow French Horn	Slow French Horn
525	Dark Brass Section	Dark Br Section
526	Bright Brass Section	Brt Br Section
527	Warm Brass Section	Warm Br Section
528	Chorus Brass Section	Cho Br Section
529	Resonant Brass Section	Reson Br Section
530	Slow Brass Section	Slow Br Section
531	Funk Brass Section	Funk Br Section
532	Jazz Brass Section	Jazz Br Section
533	Dark Synth Brass	Dark Syn Brass
534	Bright Synth Brass	Brt Syn Brass
535	Warm Synth Brass	Warm Syn Brass
536	Chorus Synth Brass	Cho Syn Brass
537	Resonant Synth Brass	Reson Syn Brass
538	Slow Synth Brass	Slow Syn Brass
539	Rock Synth Brass	Rock Syn Brass
540	Pop Synth Brass	Pop Synth Brass
541	Dark Analog Synth Brass	Dk Ana Syn Br
542	Bright Analog Synth Brass	Brt Ana Syn Br
543	Warm Analog Synth Brass	Warm Ana Syn Br
544	Chorus Analog Synth Brass	Cho Ana Syn Br
545	Resonant Analog Synth Brass	Reso Ana Syn Br
546	Slow Analog Synth Brass	Slow Ana Syn Br
547	Rock Analog Synth Brass	Rock Ana Syn Br
548	Wah Analog Synth Brass	Wah Ana Syn Br
549	Brass Section 1	Brass Section 1
550	Brass Section 2	Brass Section 2
551	Octave Brass Section	Oct Br Section
552	French Horn Live 1	Fr Horn Live 1
553	French Horn Live 2	Fr Horn Live 2

554	Brassband 2	Brassband 2
555	Brass Section 3	Brass Section 3
556	Dark Brass 1	Dark Brass 1
557	Synth Brass 1	Synth Brass 1
558	Bright Brass Section 1	Bright Brass 1
559	Sforzato Brass	Sforzato Brass
560	Brassband 3	Brassband 3
561	Club Brass Section	Club Brass
562	Bright Brass Section 2	Bright Brass 2
563	Soft Brass Section 1	Soft Brass 1
564	Synth Brass 2	Synth Brass 2
565	Soft Synth Brass 1	Soft Synth Brass 1
566	Soft Synth Brass 2	Soft Synth Brass 2
567	Jump Brass	Jump Brass
568	Soft Brass Section 2	Soft Brass 2
569	BigBand 1	BigBand 1
570	Solo Brass 1	Solo Brass 1
571	Bright Brass Section 3	Bright Brass 3
572	Synth Brass 3	Synth Brass 3
573	Solo Brass 2	Solo Brass 2
574	Soft Brass Section 3	Soft Brass 3
575	BigBand 2	BigBand 2
576	Synth Brass 4	Synth Brass 4
577	Brass Hit	Brass Hit
578	Analog Synth Brass 1	Ana Syn Br 1
579	Solo Brass 3	Solo Brass 3
580	Solo Brass 4	Solo Brass 4
581	Analog Synth Brass 2	Ana Syn Br 2
582	Funky Synth Brass 1	Funky Syn Br 1
583	Echo Brass	Echo Brass
584	Analog Synth Brass 3	Ana Syn Br 3
585	Soft Synth Brass	Soft Syn Br
586	Funky Synth Brass 2	Funky Syn Br 2
587	Tenor Sax 1	Tenor Sax 1
588	Alto Sax 1	Alto Sax 1
589	Soprano Sax 1	Soprano Sax 1
590	Baritone Sax 1	Baritone Sax 1
591	Sax Band 1	Sax Band 1
592	Sax Band 2	Sax Band 2
593	Sax & Clarinet	Sax & Clarinet
594	Sax Live 1	Sax Live 1
595	Sax Live 2	Sax Live 2
596	Soprano Sax 2	Soprano Sax 2
597	Tenor Sax 2	Tenor Sax 2
598	Alto Sax 2	Alto Sax 2
599	Baritone Sax 2	Baritone Sax 2
600	Slow Tenor Sax	Slow Tenor Sax
601	Soft Sax Band	Soft Sax Band
602	Super Sax Band	Super Sax Band
Flute & Wood Wind		
603	Flute 1	Flute 1
604	Clarinet 1	Clarinet 1
605	Pan Flute 1	Pan Flute 1
606	Oboe 1	Oboe 1
607	Flute & Sax	Flute & Sax
608	English Horn	English Horn

609	Bassoon	Bassoon
610	Sweet Flute	Sweet Flute
611	Piccolo	Piccolo
612	Clarinet & Sax	Clarinet & Sax
613	Sweet Pan Flute	Sweet Pan Flute
614	Shakuhachi	Shakuhachi
615	Clarinet 2	Clarinet 2
616	Flute 2	Flute 2
617	Pan Flute 2	Pan Flute 2
618	Oboe 2	Oboe 2
619	Whistle	Whistle
620	Recorder	Recorder
621	Blown Bottle	Blown Bottle
622	Ocarina	Ocarina
623	Dark Piccolo	Dark Piccolo
624	Bright Piccolo	Bright Piccolo
625	Chorus Piccolo	Chorus Piccolo
626	Warm Piccolo	Warm Piccolo
627	Slow Piccolo	Slow Piccolo
628	Whistle & Piccolo	Whistle & Picco
629	Dark Flute	Dark Flute
630	Bright Flute	Bright Flute
631	Chorus Flute	Chorus Flute
632	Warm Flute	Warm Flute
633	Slow Flute	Slow Flute
634	Whistle & Flute	Whistle & Flute
635	Piccolo & Recorder	Picco & Record
636	Pan Flute & Recorder	Pan Flu & Record
637	Shakuhachi & Recorder	Shaku & Record
638	Clarinet & Recorder	Clarine & Record
639	Flute & Recorder	Flute & Record
640	Blown Bottle & Recorder	BlowBot & Record
641	Dark Pan Flute	Dark Pan Flute
642	Bright Pan Flute	Bright Pan Flute
643	Warm Pan Flute	Warm Pan Flute
644	Chorus Pan Flute	Chorus Pan Flute
645	Whistle & Pan Flute	Whistle & PanFlu
646	Slow Pan Flute	Slow Pan Flute
647	Dark Blown Bottle	Dk Blown Bottle
648	Bright Blown Bottle	Brt Blown Bottle
649	Chorus Blown Bottle	Cho Blown Bottle
650	Warm Blown Bottle	Warm Blow Bottle
651	Slow Blown Bottle	Slow Blow Bottle
652	Oboe & Blown Bottle	Obo & BlowBottle
653	Dark Shakuhachi	Dark Shakuhachi
654	Bright Shakuhachi	Bright Shaku
655	Chorus Shakuhachi	Chorus Shaku
656	Warm Shakuhachi	Warm Shaku
657	Slow Shakuhachi	Slow Shakuhachi
658	Piccolo & Shakuhachi	Piccolo & Shaku
659	Bright Whistle	Bright Whistle
660	Blown Bottle & Whistle	BlowBot & Whist
661	Shakuhachi & Whistle	Shaku & Whistle
662	Oboe & Whistle	Oboe & Whistle
663	Piccolo & Ocarina	Picco & Ocarina
664	Pan Flute & Ocarina	Pan Flu & Ocari

665	Oboe & Ocarina	Oboe & Ocarina
666	Blown Bottle & Ocarina	BlowBott & Ocari
667	Shakuhachi & Ocarina	Shaku & Ocari
Lead & Pad		
668	Sine Solo 1	Sine Solo 1
669	Sine Solo 2	Sine Solo 2
670	Corrie 1	Corrie 1
671	Wire Lead 1	Wire Lead 1
672	Wire Lead 2	Wire Lead 2
673	Big Lead 1	Big Lead 1
674	Wavy Sawtooth 1	Wavy Sawtooth 1
675	Bauble Lead	Bauble Lead
676	Super Analog	Super Analog
677	Big Lead 2	Big Lead 2
678	Wire Lead 3	Wire Lead 3
679	Massiness 1	Massiness 1
680	Massiness 2	Massiness 2
681	2Oscillators Lead 1	2Oscillator Ld 1
682	2Oscillators Lead 2	2Oscillator Ld 2
683	Square	Square
684	Sawtooth	Sawtooth
685	Soft Big Lead 1	Soft Big Lead 1
686	Thick Saw 1	Thick Saw 1
687	Thick Saw 2	Thick Saw 2
688	Soft Sine 1	Soft Sine 1
689	Wah Lead 1	Wah Lead 1
690	Wah Lead 2	Wah Lead 2
691	Soft Wah Lead	Soft Wah Lead
692	Corrie 2	Corrie 2
693	Funky Lead	Funky Lead
694	Delayed Lead 1	Delayed Lead 1
695	Chiffer Lead	Chiffer Lead
696	Octave Lead	Octave Lead
697	Echo Drops 1	Echo Drops 1
698	SynCalliope Soft 1	SynCaliop Soft 1
699	Delayed Lead 2	Delayed Lead 2
700	Massiness 3	Massiness 3
701	EchoBell 1	EchoBell 1
702	SynCalliope Soft 2	SynCaliop Soft 2
703	Soft Sine 2	Soft Sine 2
704	Jazz Lead	Jazz Lead
705	Soft Big Lead 2	Soft Big Lead 2
706	EchoBell 2	EchoBell 2
707	Echo Crystal 1	Echo Crystal 1
708	EchoBell 3	EchoBell 3
709	Echo Crystal 2	Echo Crystal 2
710	Rising	Rising
711	Charang 1	Charang 1
712	Wavy Sawtooth 2	Wavy Sawtooth 2
713	Thick Square	Thick Square
714	Wah Sine Solo 1	Wah Sine Solo 1
715	TremoloMatrix	TremoloMatrix
716	DarkWire	DarkWire
717	ChorusHipLead 1	ChorusHip Lead 1
718	ChorusHipLead 2	ChorusHip Lead 2
719	Wire Lead 3	Wire Lead 3

720	Bright Hop Lead	Bright Hop Lead
721	Wah Hop Lead	Wah Hop Lead
722	TremoloBauble Lead	TreBauble Lead
723	ChorusSoftMini	ChorusSoftMini
724	Soft Trance Lead	SoftTraLead
725	Chiffe Fire Wire	ChiFireWire
726	Soft Analogon	Soft Analogon
727	BrightAnalogon	BrightAnalogon
728	Tekkline Analogon	Tekkline Ana
729	Corrie Analogon	Corrie Analogon
730	CorrieCalliope 1	CorrieCalliope 1
731	WahCalliope	WahCalliope
732	BrightCalliope	BrightCalliope
733	AnalogonCalliope1	AlgnCalliope 1
734	AnalogonCalliope2	AlgnCalliope2
735	AnalogonCalliope3	AlgnCalliope3
736	CorrieCalliope 2	CorrieCalliope 2
737	Wah Calliope	Wah Calliope
738	Soft Chiffer Lead	Soft Chiffer Ld
739	Bright Chiffer Lead	BrT Chiffer Ld
740	Tremolo Chiffer Lead	Trem Chiffer Ld
741	TrumpSaw Chiffer Lead	TrpSaw Chiff Ld
742	Analogon Chiffer Lead	Ana Chiffer Ld
743	Tekkline Chiffer Lead	Tekklin Chiff Ld
744	Corrie Chiffer Lead	Corrie Chiff Ld
745	Stardust Warp	Stardust Warp
746	Soft Funky Lead 1	Soft Funky Ld 1
747	Soft Funky Lead 2	Soft Funky Ld 2
748	Wire Funky Lead	Wire Funky Lead
749	Soft Octave Lead	Soft Octave Lead
750	Bauble Octave Lead	Bauble Octave Ld
751	Tremolo Octave Lead	Tremolo Oct Ld
752	Calliope Octave Lead	Calliope Oct Ld
753	Big Octave Lead	Big Octave Lead
754	Bright Voice Lead	Bright Voice Ld
755	Soft Voice Lead	Soft Voice Lead
756	Delayed Voice Lead 1	Dely Voice Lead1
757	Delayed Voice Lead 2	Dely Voice Lead2
758	Funky Voice Lead1	Funky Voice Ld 1
759	Funky Voice Lead2	Funky Voice Ld 2
760	Jazz Voice Lead	Jazz Voice Lead
761	Big Voice Lead	Big Voice Lead
762	Soft Rising 1	Soft Rising1
763	Soft Rising 2	Soft Rising2
764	Bright Rising 1	Bright Rising 1
765	Bright Rising 2	Bright Rising 2
766	Wah Rising 1	Wah Rising 1
767	Wah Rising 2	Wah Rising 2
768	Wah Rising 3	Wah Rising 3
769	Wah Rising 4	Wah Rising 4
770	Soft Bass Lead 1	Soft Bass Lead 1
771	Soft Bass Lead 2	Soft Bass Lead 2
772	Voice Bass Lead	Voice Bass Lead
773	Bright Bass Lead 1	Bright Bass Ld 1
774	Calliope Bass Lead	Calliope Bass Ld
775	Analogon Bass Lead	Analogon Bass Ld

776	Bright Bass Lead 2	Bright Bass Ld 2
777	Wah Bass Lead	Wah Bass Ld
778	Bright Delayed Lead	Bright Delay Ld
779	Soft Cry Eyes 1	Soft Cry Eyes 1
780	Soft Cry Eyes 2	Soft Cry Eyes 2
781	Bright Cry Eyes	Bright Cry Eyes
782	Square Cry Eyes	Square Cry Eyes
783	Analogon Cry Eyes	Ana Cry Eyes
784	Vox Cry Eyes	Vox Cry Eyes
785	Space Voice Cry Eyes	Spa Vc Cry Eyes
786	Soft Stardust 1	Soft Stardust 1
787	Soft Stardust 2	Soft Stardust 2
788	Bright Stardust 1	Brst Stardust 1
789	Bright Stardust 2	Brst Stardust 2
790	Wah Stardust 1	Wah Stardust 1
791	Warm Stardust	Warm Stardust
792	Wah Stardust 2	Wah Stardust 2
793	Square Stardust	Square Stardust
794	Space Voice 1	Space Voice 1
795	Vox Pad 1	Vox Pad 1
796	Vox Pad 2	Vox Pad 2
797	Vox Pad 3	Vox Pad 3
798	New Year Pad 1	New Year Pad 1
799	New Year Pad 2	New Year Pad 2
800	Soft Vox	Soft Vox
801	Space Voice 2	Space Voice 2
802	New Year Pad 3	New Year Pad 3
803	New Year Pad 4	New Year Pad 4
804	New Age Pad 1	New Age Pad 1
805	New Age Pad 2	New Age Pad 2
806	Soft Space Voice 1	Soft Space Vc 1
807	Bright Space Voice 1	Brst Space Vc 1
808	Bright Vox	Bright Vox
809	Bright Space Voice 2	Brst Space Vc 2
810	Soft Space Voice 2	Soft Space Vc 2
811	Choir&Organ	Choir&Organ
812	New Age Pad 3	New Age Pad 3
813	New Age Pad 4	New Age Pad 4
814	Warm Pad 1	Warm Pad 1
815	PWM Pad	PWM Pad
816	Warmly Pad 1	Warmly Pad 1
817	Warm Pad 2	Warm Pad 2
818	Sine Pad 1	Sine Pad 1
819	Warm Pad 3	Warm Pad 3
820	Sweep Pad 1	Sweep Pad 1
821	Poly Synth 1	Poly Synth 1
822	Dipolar Pad	Dipolar Pad
823	Poly Synth 2	Poly Synth 2
824	Poly Synth 3	Poly Synth 3
825	New Age Pad 3	New Age Pad 3
826	Horn Pad	Horn Pad
827	Metallic Pad 1	Metallic Pad 1
828	Metallic Pad 2	Metallic Pad 2
829	Pan Pad 1	Pan Pad 1
830	Congregate	Congregate
831	Pan Pad 2	Pan Pad 2

832	Pan Pad 3	Pan Pad 3
833	New Age Pad 4	New Age Pad 4
834	Itopia Pad 1	Itopia Pad 1
835	Itopia Pad 2	Itopia Pad 2
836	Metallic Pad 3	Metallic Pad 3
837	Metallic&Itopia	Metallic&Itopia
838	Sine Pad 2	Sine Pad 2
839	Sweep Pad 2	Sweep Pad 2
840	Analog Pad 1	Analog Pad 1
841	Analog Pad 2	Analog Pad 2
842	Bowed Pad 1	Bowed Pad 1
843	New Age&Bowed Pad 1	NewAge&Bow Pd 1
844	New Age&Bowed Pad 2	NewAge&Bow Pd 2
845	Halo Pad 1	Halo Pad 1
846	Halo&Bowed Pad	Halo&Bowed Pad
847	Poly Pad	Poly Pad
848	Slow Warm Pad	Slow Warm Pad
849	Bright New Age Pad	Brst New Age Pd
850	Warmly New Age Pad1	Warm New Age Pd1
851	Metallic New Age Pad	Metal New Age Pd
852	New Age Tune Pad	New Age Tune Pad
853	Choir New Age Pad	Choir New Age Pd
854	Warmly New Age Pad2	Warm New Age Pd2
855	Dipolar New Age Pad	Dipol New Age Pd
856	Wah New Age Pad	Wah New Age Pad
857	Warmly Pad	Warmly Pad
858	Warmly Pad 2	Warmly Pad 2
859	BigBand Pad	BigBand Pad
860	Organ Pad	Organ Pad
861	12-String Guitar Pad	12-String Gt Pd
862	Modern Pad	Modern Pad
863	Bright Pad 1	Bright Pad 1
864	Bright Pad 2	Bright Pad 2
865	Soft PolySy Pad	Soft PolySy Pad
866	Bright PolySy Pad	Bright PolySy Pd
867	Wah PolySy Pad	Wah PolySy Pad
868	Vox PolySy Pad	Vox PolySy Pad
869	Calliope PolySy Pad	Callio PolySy Pd
870	Harmonica PolySy Pad	Harm PolySy Pd
871	Analogon PolySy Pad	Ana PolySy Pd
872	Square PolySy Pad	Square PolySy Pd
873	Wah Space Voice 1	Wah Space Vc 1
874	Wah Space Voice 2	Wah Space Vc 2
875	Soft Itopia Pad 1	Soft Itopia Pd 1
876	Square Itopia Pad	Squar Itopia Pd
877	Bright Itopia Pad 1	Brst Itopia Pd 1
878	Analogon Itopia Pad	Ana Itopia Pd
879	Bright Itopia Pad 2	Brst Itopia Pd 2
880	Soft Itopia Pad 2	Soft Itopia Pd 2
881	Bright Bowed Pad 1	Brst Bowed Pd 1
882	Soft Bowed Pad 1	Soft Bowed Pad 1
883	Wah Bowed Pad	Wah Bowed Pad
884	Corrie Bowed Pad	Corrie Bowed Pd
885	Congregate Bowed Pad	Cong Bowed Pd
886	Calliope Bowed Pad	Calliop Bowed Pd
887	Bright Bowed Pad 2	Brst Bowed Pd 2

888	Soft Bowed Pad 2	Soft Bowed Pad 2
889	Bright Metal Pad 1	Brnt Metal Pd 1
890	Soft Metal Pad	Soft Metal Pad
891	Wah Metal Pad	Wah Metal Pad
892	Space Voice Metal Pad	Space Vc Met Pd
893	Modern Metal Pad	Modern Metal Pad
894	Congregate Metal Pad	Cong Metal Pd
895	Calliope Metal Pad	Calliop Metal Pd
896	Bright Metal Pad 2	Brnt Metal Pd 2
897	Bright Halo Pad	Bright Halo Pad
898	Soft Halo Pad	Soft Halo Pad
899	Wah Halo Pad	Wah Halo Pad
900	PWM Halo Pad	PWM Halo Pad
901	Bowed Halo Pad	Bowed Halo Pad
902	Congregate Halo Pad	Cong Halo Pd
903	Metal Halo Pad	Metal Halo Pad
904	Corrie Halo Pad	Corrie Halo Pad
905	Soft Dipolar Pad	Soft Dipolar Pad
906	Wah Dipolar Pad	Wah Dipolar Pad
907	Vox Dipolar Pad	Vox Dipolar Pad
908	Metallic Dipolar Pad	Metal Dipolar Pd
909	Warmly Dipolar Pad	Warm Dipolar Pd
910	Congregate Dipolar Pad	Cong Dipolar Pd
911	Calliope Dipolar Pad	Calli Dipolar Pd
912	Corrie Dipolar Pad	Corie Dipolar Pd
Synth FX & Sound Effects		
913	Guitar Fret Noise	GtFret Noise
914	Guitar Cutting Noise	GtCutting Noise
915	Acoustic Bass String Slap	Bass String Slap
916	Breath Noise	Breath Noise
917	Flute Key Click	Flute Key Click
918	Seashore	Seashore
919	Rain	Rain
920	Thunder	Thunder
921	Wind 1	Wind 1
922	Stream	Stream
923	Bubble	Bubble
924	Bird Tweet 1	Bird Tweet 1
925	Dog	Dog
926	Horse Gallop	Horse Gallop
927	Bird Tweet 2	Bird Tweet 2
928	Telephone Ring 1	Telephone Ring 1
929	Telephone Ring 2	Telephone Ring 2
930	Door Creaking	Door Creaking
931	Door	Door
932	Scratch	Scratch
933	Wind Chime	Wind Chime
934	Helicopter	Helicopter
935	Car Engine	Car Engine
936	Car Stop	Car Stop
937	Car Pass	Car Pass
938	Car Crash	Car Crash
939	Siren	Siren
940	Train	Train
941	Jetplane	Jetplane

942	Starship	Starship
943	Burst Noise	Burst Noise
944	Applause	Applause
945	Laughing	Laughing
946	Screaming	Screaming
947	Punch	Punch
948	Heart Beat	Heart Beat
949	Footsteps	Footsteps
950	Gunshot	Gunshot
951	Machine Gun	Machine Gun
952	Lasergun	Lasergun
953	Explosion	Explosion
Ethnic & Combined		
954	Fiddle	Fiddle
955	Sitar	Sitar
956	Hackbrett	Hackbrett
957	Banjo	Banjo
958	Shamisen	Shamisen
959	Koto	Koto
960	Kalimba	Kalimba
961	Shanai	Shanai
962	Bag Pipe	Bag Pipe
963	Stereo Piano & Strings	Piano&Strings
964	Stereo Piano & Calliope	Piano&Calliope
965	Stereo Piano & Sweep	Piano&Sweep
966	Honky Tonk Piano & Fifths	Honk&Fifths
967	Honky Tonk Piano & Sweep	Honk&Sweep
968	FM Electric Piano	FM E.Piano
969	Digital Piano	Digital Piano
970	E.Piano & Pad	E.Piano&Pad
971	E.Piano & Sweep	E.Piano&Sweep
Perc/Drum		
972	Vibraphone (wide) 1	Vibraphone/Wide 1
973	Rigid Vibraphone	Rigid Vibraphone
974	Vibraphone 1	Vibraphone 1
975	Steel Drums 1	Steel Drums 1
976	Celesta 1	Celesta 1
977	Vibraphone 2	Vibraphone 2
978	Vibraphone 3	Vibraphone 3
979	Music Box & Flute	Music Box&Flute
980	Marimba 1	Marimba 1
981	Xylophone 1	Xylophone 1
982	Steel Drums 2	Steel Drums 2
983	Celesta 2	Celesta 2
984	Glockenspiel 1	Glockenspiel 1
985	Music Box 1	Music Box 1
986	Tubular Bells 1	Tubular Bells 1
987	Church Bell 1	Church Bell 1
988	Carillon 1	Carillon 1
989	Dulcimer 1	Dulcimer 1
990	Timpani 1	Timpani 1
991	Taiko Drum	Taiko Drum
992	Concert Bass Drum	Concert Ba Drum
993	Melodic Tom 1	Melodic Tom 1
994	Melodic Tom 2	Melodic Tom 2
995	Synth Drum	Synth Drum

996	Rhythm Box Tom	Rhythm Box Tom
997	Electric Drum	Electric Drum
998	Reverse Cymbal	Reverse Cymbal
999	Standard Set 1	Standard Set 1
1000	Standard Set 2	Standard Set 2
1001	Jazz Set	Jazz Set
1002	Brush Set	Brush Set
1003	Dance Set 1	Dance Set 1
1004	Room Set	Room Set
1005	Power Set	Power Set
1006	Electronic Set	Electronic Set
1007	Analog Set	Analog Set
1008	Dance Set 2	Dance Set 2
1009	Orchestra Set	Orchestra Set
1010	SFX Set	SFX Set
1011	Studio Set	Studio Set
GM		
1012	Acoustic Grand Piano	Grand Piano
1013	Acoustic Grand Piano (wide)	Grand Piano/Wide
1014	Acoustic Grand Piano (dark)	Grand Piano/Dark
1015	Bright Acoustic Piano	Bright Piano
1016	Bright Acoustic Piano (wide)	Bright Piano/Wide
1017	Electric Grand Piano	Electric Grand
1018	Electric Grand Piano (wide)	Elec.Grand/Wide
1019	Honky Tonk Piano	Honky Tonk
1020	Honky Tonk Piano (wide)	Honky Tonk/Wide
1021	Electric Piano 1	E.Piano 1
1022	Electric Piano 2	E.Piano 2
1023	Detuned Electric Piano 1	Detuned EP 1
1024	Electric Piano 1 (velocity mix)	Velocity EP 1
1025	60's Electric Piano	60's EP
1026	Detuned Electric Piano 2	Detuned EP 2
1027	Electric Piano 2 (velocity mix)	Velocity EP 2
1028	EP Legend	EP Legend
1029	Phase EP 1	Phase EP 1
1030	Harpsichord	Harpsichord
1031	Harpsichord (octave mix)	Harpsichord/Octave
1032	Harpsichord (wide)	Harpsichord/Wide
1033	Harpsichord (with key off)	Harpsichord/KeyOff
1034	Clavi	Clavi
1035	Pulse Clavi	Pulse Clavi
1036	Celesta	Celesta
1037	Glockenspiel I	Glockenspiel I
1038	Music Box	Music Box
1039	Vibraphone	Vibraphone
1040	Vibraphone (wide)	Vibraphone/Wide
1041	Marimba	Marimba
1042	Marimba (wide)	Marimba/Wide
1043	Xylophone	Xylophone
1044	Tubular Bells	Tubular Bells
1045	Church Bell	Church Bell
1046	Carillon	Carillon
1047	Dulcimer	Dulcimer
1048	Drawbar Organ	Drawbar Organ
1049	Detuned Drawbar Organ	Detuned DrawOrg
1050	Italian 60's Organ	60's Organ
1051	Drawbar Organ 2	Drawbar Organ 2

1052	Percussive Organ	Percussive Organ
1053	Detuned Percussive Organ	Detuned PercOrgan
1054	Percussive Organ 2	Percussive Organ 2
1055	Rock Organ	Rock Organ
1056	Church Organ	Church Organ
1057	Church Organ (octave mix)	ChurchOrg/Octave
1058	Detuned Church Organ	Detune ChurchOrg
1059	Reed Organ	Reed Organ
1060	Puff Organ	Puff Organ
1061	Accordion	Accordion
1062	Accordion 2	Accordion 2
1063	Harmonica	Harmonica
1064	Tango Accordion	Tango Accordion
1065	Acoustic Guitar (nylon)	Nylon Guitar
1066	Ukulele	Ukulele
1067	Acoustic Guitar (nylon + key off)	NylonGtr/KeyOff
1068	Acoustic Guitar (nylon 2)	Nylon Guitar 2
1069	Acoustic Guitar (steel)	Steel Guitar
1070	12-String Guitar	12String Guitar
1071	Mandolin	Mandolin
1072	Steel Guitar with Body Sound	SteelGtr/BodySd
1073	Electric Guitar (jazz)	Jazz Guitar
1074	Electric Guitar (pedal steel)	Pedal Guitar
1075	Electric Guitar (clean)	Clean Guitar
1076	Electric Guitar (detuned clean)	Detuned CleanGtr
1077	Mid Tone Guitar	Mid Tone Guitar
1078	Electric Guitar (muted)	Muted Guitar
1079	Electric Guitar (funky cutting)	Funk Guitar
1080	Electric Guitar (muted velo-sw)	Velocity MutedGtr
1081	Jazz Man	Jazz Man
1082	Overdriven Guitar	OverdrivenGtr
1083	Guitar Pinch	Guitar Pinch
1084	Distortion Guitar	DistortionGtr 1
1085	Distortion Guitar (with feedback)	Feedback Guitar
1086	Distorted Rhythm Guitar	Rhythm DistGtr
1087	Guitar Harmonics	Guitar Harmonics
1088	Guitar Feedback	Feedback Guitar 3
1089	Acoustic Bass	Acoustic Bass
1090	Electric Bass (finger)	Finger Bass
1091	Finger Slap Bass	Finger Slap Bass
1092	Electric Bass (pick)	Pick Bass
1093	Fretless Bass	Fretless Bass
1094	Slap Bass 1	Slap Bass 1
1095	Slap Bass 2	Slap Bass 2
1096	Synth Bass 1	Synth Bass 1
1097	Synth Bass 2	Synth Bass 2
1098	Synth Bass (warm)	Warm Synth Bass
1099	Synth Bass 3 (resonance)	Resonance SynBass
1100	Clavi Bass	Clavi Bass
1101	Hammer	Hammer
1102	Synth Bass 4 (attack)	Attack Bass
1103	Synth Bass (rubber)	Rubber Bass
1104	Attack Pulse	Attack Pulse
1105	Violin	Violin
1106	Violin (slow attack)	Slow Violin
1107	Viola	Viola

1108	Cello	Cello
1109	Contrabass	Contrabass
1110	Tremolo Strings	Tremolo Strings
1111	Pizzicato Strings	Pizzicato Str
1112	Orchestral Harp	Orchestral Harp
1113	Yang Chin	Yang Chin
1114	Timpani 1	Timpani 1
1115	String Ensembles 1	String Ensembles 1
1116	String Ensembles 2	String Ensembles 2
1117	Strings & Brass	Strings&Brass
1118	60's Strings	60's Strings
1119	Synth Strings 1	Synth Strings 1
1120	Synth Strings 2	Synth Strings 2
1121	Synth Strings 3	Synth Strings 3
1122	Choir Aahs	Choir Aahs
1123	Choir Aahs 2	Choir Aahs 2
1124	Voice Oohs	Voice Oohs
1125	Humming	Humming
1126	Analog Voice	Analog Voice
1127	Synth Voice	Synth Voice
1128	Orchestra Hit	Orchestra Hit
1129	Bass Hit Plus	Bass Hit Plus
1130	6th Hit	6th Hit
1131	Euro Hit	Euro Hit
1132	Trumpet	Trumpet
1133	Dark Trumpet Soft	DarkTrump Soft
1134	Trombone	Trombone
1135	Trombone 2	Trombone 2
1136	Bright Trombone	Bright Trombone
1137	Tuba	Tuba
1138	Muted Trumpet	Muted Trumpet
1139	Muted Trumpet 2	Muted Trumpet 2
1140	French Horn	French Horn
1141	French Horn 2 (warm)	French Horn 2
1142	Brass Section	Brass Section
1143	Brass Section 2 (octave mix)	Brass Section 2
1144	Synth Brass 1	Synth Brass 1
1145	Synth Brass 2	Synth Brass 2
1146	Synth Brass 3	Synth Brass 3
1147	Synth Brass 4	Synth Brass 4
1148	Analog Synth Brass 1	Analog SynBrass 1
1149	Analog Synth Brass 2	Analog SynBrass 2
1150	Jump Brass	Jump Brass
1151	Soprano Sax	Soprano Sax
1152	Alto Sax	Alto Sax
1153	Tenor Sax	Tenor Sax
1154	Baritone Sax	Baritone Sax
1155	Oboe	Oboe
1156	English Horn	English Horn
1157	Bassoon	Bassoon
1158	Clarinet	Clarinet
1159	Piccolo	Piccolo
1160	Flute	Flute
1161	Recorder	Recorder
1162	Pan Flute	Pan Flute

1163	Blown Bottle	Blown Bottle
1164	Shakuhachi	Shakuhachi
1165	Whistle	Whistle
1166	Ocarina	Ocarina
1167	FX 1 (rain)	FX 1 Rain
1168	FX 2 (soundtrack)	FX 2 SoundTrack
1169	FX 3 (crystal)	FX 3 Crystal
1170	FX 3a (synth mallet)	Synth Mallet
1171	FX 4 (atmosphere)	FX 4 Atmosphere
1172	FX 5 (brightness)	FX 5 Brightness
1173	FX 6 (goblins)	FX 6 Goblins
1174	FX 7 (echoes)	FX 7 Echoes
1175	FX 7a (echo bell)	Echo bell
1176	FX 7b (echo pan)	Echo pan
1177	FX 8 (sci-fi)	FX 8 Sci-Fi
1178	Sitar	Sitar
1179	Sitar 2 (bend)	Sitar 2/Bend
1180	Banjo	Banjo
1181	Shamisen	Shamisen
1182	Koto	Koto
1183	Taisho Koto	Taisho Koto
1184	Kalimba	Kalimba
1185	Bag Pipe	Bag Pipe
1186	Fiddle	Fiddle
1187	Shanai	Shanai
1188	Tinkle Bell	Tinkle Bell
1189	Agogo	Agogo
1190	Steel Drums	Steel Drums
1191	Woodblock	Woodblock
1192	Castanets	Castanets
1193	Taiko Drum	Taiko Drum
1194	ConcertBass Drum	ConBass Drum
1195	Melodic Tom	Melodic Tom
1196	Melodic Tom 2 (power)	Power Melodic Tom
1197	Synth Drum	Synth Drum
1198	Rhythm Box Tom	Rhythm Box Tom
1199	Electric Drum	Electric Drum
1200	Reverse Cymbal	Reverse Cymbal

Style list

No.	Style Name
8BEAT & 16BEAT	
1	8Beat Pop 1
2	Pop Rock 1
3	8Beat Rock
4	8Beat Ballad
5	Pop Jazz
6	8Beat 1
7	8Beat Pop 2
8	Pop Funk 1
9	Rhythm&Beat 1
10	8Beat Disco 1
11	Guitar Pop 1
12	Guitar Pop 2
13	8Beat 2
14	Sweet Beat
15	8Beat Dance
16	8Beat Disco 2
17	Pop Funk 2
18	8Beat 3
19	60's 8Beat
20	Rhythm&Beat 2
21	16Beat 1
22	16Beat Funk 1
23	16Beat Ballad 1
24	16Beat R&B
25	16Beat Pop 1
26	16Beat Funk 2
27	16Beat Dance
28	16Beat Pop 2
29	16Beat 2
30	16Beat Pop 3
31	16Beat Pop 4
32	Modern 16Beat
33	16Beat Hot
34	16Beat Modern
35	16Beat Funk 3
36	16Beat 3
37	Cool Beat
38	16Beat Ballad 2
39	16Beat 4
40	Pop Shuffle
ROCK	
41	Blues Rock
42	Hard Rock
43	Rock
44	New Wave
45	80's metal
46	Ska
47	Pop Rock 2
48	Pop Rock 3
49	Standard Rock
50	Slow Rock
51	70's Rock&Roll
52	Folk Rock
53	Soft Rock

54	Old Rock
55	Easy Rock
56	New Shuffle
57	Rock Hip Hop
58	Rock&Roll 1
59	Rock Shuffle
60	Rock&Roll 2
POP & BALLAD	
61	Sweet Ballad
62	Piano Ballad
63	BriPop 1
64	6-8Ballad
65	Unplugged
66	Pop Rock 4
67	Pop Dance 1
68	Pop Fusion
69	Analog Night 1
70	6/8 Pop
71	Brit. Pop 1
72	Brit. Pop 2
73	Pop Hit
74	Fusion Shuffle
75	Analog Night 2
76	Guitar Pop 3
77	Pop Beat
78	Soft Beat
79	60's Pop
80	Sting Latin
81	R&B Ballad 1
82	Guitar Ballad
83	Ballad Rock
84	Piano Pop 1
85	Soft Ballad
86	Natural Ballad
87	Love Ballad
88	Easy Ballad
89	Miami Folk
90	Slow Ballad
91	Folk Ballad
92	Pop Ballad 1
93	Pop Ballad 2
94	EP Ballad
95	New R&B Ballad
BALLROOM	
96	Tango 1
97	Spain Matador
98	Twist 1
99	Twist 2
100	Big Band Fox
101	Tango 2
102	Tango 3
103	Slow Fox
104	Slow Waltz 1
105	Swing Fox
106	Salsa 1
107	Pop Cha Cha

108	Cha Cha 1
109	Cha Cha 2
110	Beguine 1
111	Beguine 2
112	Rumba 1
113	Samba 1
114	Samba 2
115	Jive
116	Fox Trot
DANCE	
117	Techno 1
118	Hip Hop 1
119	House 1
120	House 2
121	Pop Dance 2
122	Down Beat
123	Progressive House
124	Dubstep
125	Techno 2
126	Progressive
127	Rap 1
128	Rap 2
129	Discc
130	Soft Disco
131	Discc Party
132	70's Disco
133	70's Disco Funk
134	Club Dance
135	Euro Dance
136	Hip Hop 2
137	Garage
SOUL & FUNK	
138	Pop funk
139	New R&B
140	Pop R&B
141	Neo-Soul
142	Funk 1
143	Classic Funk
144	Jay R&B
145	Gospel Swing
146	Gospel
147	Funk 2
148	Electric Funk
149	Groove Funk
150	Rubber Funk
151	Cool Funky
152	Jazz Funk
153	Groove
154	Soul
155	Hip Hop Soul
156	Hip Hop Beat
157	R&B
158	Soul Beat
159	R&B Ballad 2
160	British Soul Pop
SWING & JAZZ	
161	Modern Big Band

162	Gospel Swing
163	Piano Jazz
164	Smooth Jazz
165	Smooth Operator
166	Latin Jazz 1
167	Big Band
168	Dixieland 1
169	Guitar Swing 1
170	Broadway Big Band
171	Swing
172	Latin Jazz 2
173	Fusion
174	Acid Jazz
175	Cool Jazz Ballad
176	Swing Shuffle
177	Big Band Medium
178	Dixieland 2
179	Acoustic Jazz
180	Guitar Swing 2
181	Ragtime
182	Modern Jazz Ballad
183	Swing Ballad
184	Orchestra Swing
COUNTRY	
185	Ballad Country 1
186	70's Country Rock
187	Ballad Country 2
188	Modern Country 1
189	Dixie Chicks
190	Country Pop 1
191	Bluegrass 1
192	Bluegrass 2
193	8Beat Country
194	Modern Country 2
195	Country Pop 2
196	Country Pop 3
197	Bluegrass 3
198	2/4 Country
199	Country Quick Steps
200	Country Folk
201	Country Shuffle
LATIN & LATIN DANCE	
202	Samba 3
203	Bossa Nova
204	Latin
205	New Reggae
206	Reggae Dance
207	Paso Doble
208	Lite Bossa
209	Latin Rock
210	Beguine 3
211	Slow Bolero
212	Disco Samba
213	Mambo
214	Meneito
215	Rumba 2
216	Rumba 3

217	Tikitita
218	Lambada
219	Pop Cha Cha 1
220	Pop Cha Cha 2
221	Salsa 2
WALTZ & TRADITIONAL	
222	Waltz
223	Old Waltz
224	English Waltz
225	German Waltz
226	Italian Mazurka
227	Mexico Waltz
228	Vienna Waltz
229	Slow Waltz 2
230	Jazz Waltz
231	Polka
232	6/8 March
233	German Polka
234	Party Polka
235	Army March
236	March
237	US March
238	Musette
239	French Musette
240	Mazurka
WORLD	
241	Enka Ballad
242	Laendler
243	Hawaiian
244	Sirtake
245	Dangdut
246	6/8 Flipper
247	New Age
248	Tarantella
249	Scottish
250	Norteno
PIANIST	
251	Pianist 1
252	Pianist 2
253	Pianist 3
254	Jazz 1
255	Jazz 2
256	Jazz Pub
257	Piano Rock
258	Pop Bossa
259	March 1
260	March 2
261	Piano Beat
262	Piano Bar
263	Blues
264	Pop Waltz
265	Slow Waltz
266	Ballad 1
267	Ballad 2
268	6/8 Ballad
269	Pop 1
270	Pop 2

Song list

No.	English Name	LCD Name
FOLK & COUNTRY		
1	Red River Valley	Red River Valley
2	Troika	Troika
3	Oh! Susanna!	Oh! Susanna!
4	Wave Of The Danube	Wave of Danube
5	Long Long Ago	Long Long Ago
6	Old Folks at Home	Old Folks at Home
7	Jambalaya	Jambalaya
8	Ding! Dong! Merrily On High	Ding! Dong!
9	Battle Hymn Of The Republic	Battle Hymn
10	The Old Gray Mare	The Old Gray Mare
11	American Patrol	American Patrol
12	Christmas Is Coming	Christmas Coming
13	Sippin' Cider Through A Straw	Sipping Cider
14	Christmas Sound	Christmas Sound
15	On London Bridge	On London Bridge
GOLDEN & POP		
16	House Of The Rising Sun	House of Rising
17	The Blue Bells Of Scotland	The Blue Bells
18	Beautiful Dreamer	Beautiful Dreamer
19	It's Been A Long, Long Time	Been a Long Time
20	O Sole Mio	O Sole Mio
21	Der Deitcher's Dog	Der Deitcher's Dog
22	Joy To The World	Joy to the World
23	Silent Night	Silent Night
24	Ave Maria	Ave Maria
25	Five Hundred Miles	Five Hundred Mil
26	Happy New Year	Happy New Year
27	It's Beginning To Look A Lot Like Christmas	Like Christmas
28	Jeanie With The Light Brown Hair	Jeanie
29	Music Box Dancer	Music Box Dancer
30	Go Tell It On The Mountain	Tell it on Mountain
31	Entertainer	Entertainer
32	Annie Laurie	Annie Laurie
33	Rumba Romance	Rumba Romance
34	The Last Rose Of Summer	Rose of Summer
35	The Old King Cole	The Old King Cole
JAZZ & FUSION		
36	Samba In June	Samba in June
37	Funk	Funk
38	I Can...	I Can...
39	Sea Shore	Sea Shore
40	Guitar&Saxphone	Guitar&Saxphone
41	The Hip Hop's Night	HipHop's Night
42	Blue Lunch	Blue Lunch
43	Cobweb	Cobweb
44	Wine	Wine
45	Jazz Old Man	Jazz Old Man
46	Dark Eyes	Dark Eyes
47	Carlos	Carlos
48	Sad	Sad
PIANO		
49	Lyrical Rondo	Lyrical Rondo
50	Rialto Ripples (Rag)	Rialto Ripples (Rag)
51	Neapolitan Song	Neapolitan Song
52	Waltzes	Waltzes
53	Turkish March	Turkish March
54	Schos Doll's Dance No. 2	Doll's Dance No.2

55	Minuet In D Major	Minuet in D Major
56	Inquietude	Inquietude
57	Italian Polka	Italian Polka
58	Moment Musical	Moment Musical
59	Prelude In C-Sharp Major	Prelude in C-Sharp Maj
60	The Happy Farmer	The Happy Farmer
61	The Rag-Time Dance	The Rag-Time Dance
62	Piano Sonata In C Major, K.330. III	Sonata K.330.III
63	Mazurka	Mazurka
64	Prelude In E Major	Prelude in E Major
65	Piano Sonata In A Major, K.331. I	Sonata K.331.I
66	Waltz For Piano In g-Sharp Minor	Waltz in g-Sharp
67	Gavotte	Gavotte
68	L' Arabesque	L' Arabesque
69	Austria Variation	Austria Variation
70	Schos Doll's Dance No. 7	Doll's Dance No.7
71	To A Wild Rose	To a Wild Rose
72	Gavotte I	Gavotte I
73	Waltz	Waltz
74	Minuet In G Major (BWV Anh. 116)	Minuet in G 2
75	Innocence	Innocence
76	Tchaikovsky Waltz	Tchaikovsky Waltz
77	Salut d' Amour	Salut d' Amour
78	Barcarolle	Barcarolle
79	Robot Doll	Robot Doll
80	Consolation	Consolation
81	2-Part Invention #13 In A Minor.B.W. Iii	Invention A2 Voix
82	Minuet In G Major (BWV Anh. 114)	Minuet in G 1
83	Barcarolle	Barcarolle
84	Norwegian Dance No.2	Norwegian Dance No.2
85	Moseta Dance	Moseta Dance
86	The Small Gathering	The Small Gathering
87	The Return	The Return
88	The Wagtail	The Wagtail
89	Bulie Dance	Bulie Dance
90	Tender Blossom	Tender Blossom

Demo song list

No.	Demo Name	LCD Name
1	Demo1	Demo1
2	Demo2	Demo2
3	Demo3	Demo3

Chord list

Chord Name (Abbreviation)	Normal Voicing	Chord	Display
Major [M]	1-3-5	C	C
Major sixth [6]	1-(3)-5-6	C6	C6
Major seventh [M7]	1-3-(5)-7	CM7	CM7
Major seventh sharp eleventh [M7#11]	1-(2)-3-#4-(5)-7	CM7#11	CM7#11
Major add ninth [Madd9]	1-2-3-5	Cmadd9	CM(9)
Major ninth [M9]	1-2-3-(5)-7	CM9	CM7(9)
Major sixth add ninth [6 9]	1-2-3-(5)-6	C6 9	C6(9)
Augmented [aug]	1-3-#5	Caug	Caug
Minor [m]	1-b3-5	Cm	Cm
Minor sixth [m6]	1-b3-5-6	Cm6	Cm6
Minor seventh [m7]	1-b3-(5)-b7	Cm7	Cm7
Minor seventh flatted fifth [m7b5]	1-b3-b5-b7	Cm7b5	Cm7b5
Minor add ninth [madd9]	1-2-b3-5	Cmadd9	Cm(9)
Minor ninth [m9]	1-2-b3-(5)-b7	Cm9	Cm7(9)
Minor eleventh [m11]	1-(2)-b3-4-5-(b7)	Cm11	Cm7(11)
Minor major ninth [mM7]	1-b3-(5)-7	CmM7	CmM7
Minor major ninth [mM9]	1-2-b3-(5)-7	CmM9	CmM7(9)
Diminished [dim]	1-b3-b5	Cdim	Cdim
Diminished seventh [dim7]	1-b3-b5-6	Cdim7	Cdim7
Seventh [7]	1-3-(5)-b7	C7	C7
Seventh suspended fourth [7sus4]	1-4-5-b7	C7sus4	C7sus4
Seventh flatted fifth [7b5]	1-3-b5-b7	C7b5	C7b5
Seventh ninth [7 9]	1-2-3-(5)-b7	C7 9	C7(9)
Seventh sharp evelenth [7#11]	1-2-3-#4-(5)-b7 or 1-(2)-3-#4-5-b7	C7#11	C7(#11)
Seventh thirteenth [7 13]	1- 3-(5)-6-b7 or 2- 3-5-6-b7	C7 13	C7(13)
Seventh flatted ninth [7b9]	1-b2-3-(5)-b7	C7b9	C7(b9)
Seventh flatted thirteenth [7b13]	1-3-5-b6-b7	C7b13	C7(b13)
Seventh sharp ninth [7#9]	(1)-#2-3-(5)-b7	C7#9	C7(#9)
Major seventh augmented [M7aug]	1-3-#5-7	CM7aug	CM7aug
Seventh augmented [7aug]	(1)-3-#5-b7	C7aug	C7aug
Suspended fourth [sus4]	1-4-5	Csus4	Csus4
One plus two plus five [1+2+5]	1-2-5	C1+2+5	C

MIDI Implementation Table

Function		Transmitted	Recognized	Remarks
Basic Channel	Default	1ch	ALL	
	Changed	1-16ch	1-16ch	
Mode	Default	x	3	
	Messages	x	3	
	Altered	*****	x	
Note Number	Note	0—127	0—127	
	:True voice	*****	0—127	
Velocity	Note on	o 9nH,V=1-127	o 9nH,V=1-127	
	Note off	x (9nH,V=0)	o(9nH,V=0; 8nH,V=0-127)	
After Touch	key's	x	x	
	Ch's	x	x	
Pitch Bend		x	o	
Control Change	0	o	o	Bank Select
	1	x	o	Modulation
	5	x	o	Portamento Time
	6	o	o	Data Entry
	7	o	o	Volume
	10	x	o	Pan
	11	x	o	Expression
	64	o	o	Sustain Pedal
	65	x	o	Portamento ON/OFF
	66	o	o	Sostenuto Pedal
	67	o	o	Soft Pedal
	80	x	x	Reverb Program
	81	x	x	Chorus Program
	91	o	o	Reverb Level
	93	o	o	Chorus Level
120	x	o	All Sound Off	
121	x	x	Reset All Controllers	
123	o	o	All Notes Off	
Program Change	:true	*****	0—127	
System Exclusive		x	o	
System Common	:SongPosition	x	x	
	:Song Select	x	x	
	:Tune	x	x	
System Real Time	:Clock	o	x	
	:Commands	x	x	
Aux Messages	:LOCAL ON/OFF	x	x	
	:Active sense	o	o	
	:Reset	x	o	
Notes:				

- Mode 1: OMNI ON, POLY
- Mode 2: OMNI ON, MONO

- Mode 3: OMNI OFF, POLY
- Mode 4: OMNI OFF, MONO

- o: YES
- x: NO

WEEE/CE Declaration

Your product has been designed and manufactured with high-quality materials and components that are recyclable and can be reused. This symbol means that electrical and electronic devices must be disposed of separately from household waste at the end of their useful life. Please dispose of this device at your local municipal collection point or recycling center. Please help preserve the environment in which we live.

We reserve the right to make technical changes and changes to the appearance. All information is correct at the time of printing. Musikhaus Kirstein GmbH accepts no liability for the accuracy and completeness of the descriptions, illustrations, and information contained herein. The colors and specifications shown may differ slightly from the product. Musikhaus Kirstein GmbH products are only available from authorized dealers. Distributors and dealers are not authorized representatives of Musikhaus Kirstein GmbH and have no authority to legally bind Musikhaus Kirstein GmbH in any way, whether expressly or by conclusive action, either expressly or by conclusive action. This
This operating manual is protected by copyright. Any reproduction or reprinting, even in part, and any reproduction of the illustrations, even in a modified form, is only permitted with the written consent of Musikhaus Kirstein GmbH.

SIMPLIFIED EU DECLARATION OF CONFORMITY

Musikhaus Kirstein GmbH hereby declares that the radio equipment type [Classic Cantabile GP-A 810] complies with Directive 2014/53/EU. The full text of the EU Declaration of Conformity is available at the following Internet address:

http://www.kirstein.de/docs/Konformitaetserklaerung/CE_Konformitaetserklaerung_00055903.pdf

 **KIRSTEIN.de**

Musikhaus Kirstein GmbH
Bernbeurener Str. 11
86956 Schongau – Germany
Phone: 0049-8861-909494-0
Email: info@kirstein.de

